

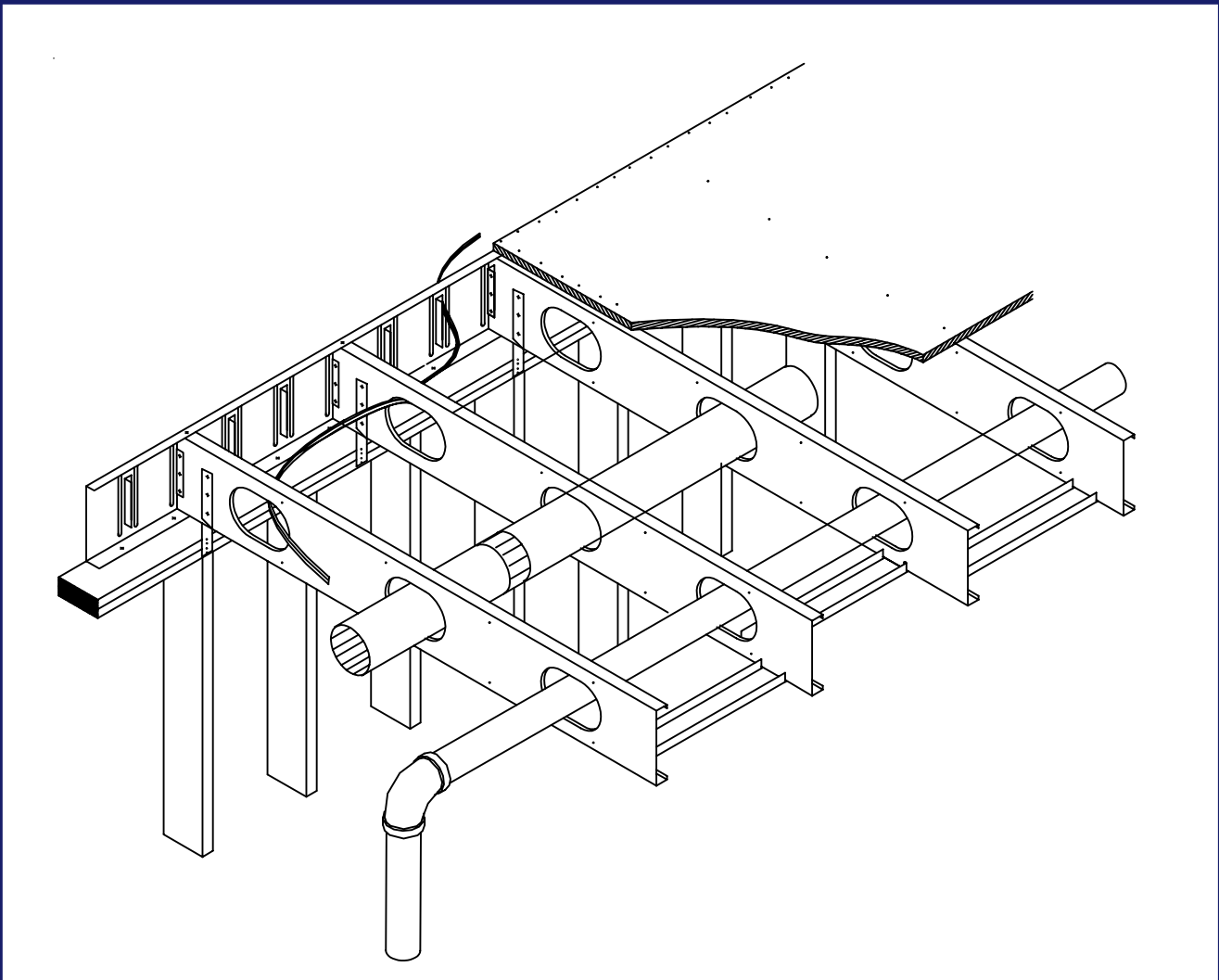

Builders' Guide to Residential Steel Floors



PATH (Partnership for Advancing Technology in Housing) is a new private/public effort to develop, demonstrate, and gain widespread market acceptance for the “Next Generation” of American housing. Through the use of new or innovative technologies, the goal of PATH is to improve the quality, durability, environmental efficiency, and affordability of tomorrow’s homes.

PATH, initiated jointly by the Administration and Congress, is managed and supported by the Department of Housing and Urban Development (HUD). In addition, all Federal Agencies that engage in housing research and technology development are PATH Partners, including the Departments of Energy and Commerce, as well as the Environmental Protection Agency (EPA) and the Federal Emergency Management Agency (FEMA). State and local governments and other participants from the private sector are also partners in PATH. Product manufacturers, home builders, insurance companies, and lenders represent private industry in the PATH Partnership.

To learn more about PATH, please contact:



*451 7th Street, SW
Suite B 133
Washington, DC 20410
202-708-4250 (fax)
email: pathnet@pathnet.org
website: www.pathnet.org*

Visit PD&R’s Web Site

www.huduser.org

*to find this report and others sponsored by
HUD’s Office of Policy Development and Research (PR&R).*

Other services of HUD USER, PD&R’s Research Information Service, include listservs; special interest, bimonthly publications (best practices, significant studies from other sources); access to public use databases; hotline 1-800-245-2691 for help accessing the information you need.

Builders' Guide to Residential Steel Floors

Prepared for:

U.S. Department of Housing and Urban Development
Office of Policy Development and Research
Washington, DC

The National Association of Home Builders
Washington, DC

Dietrich Industries, Inc.
Pittsburgh, PA

Prepared by:

NAHB Research Center, Inc.
Upper Marlboro, MD

May 2001

Acknowledgements

This report was prepared by the NAHB Research Center, Inc., under sponsorship of the U.S. Department of Housing and Urban Development (HUD), the National Association of Home Builders (NAHB) and Dietrich Industries, Inc. Special appreciation is extended to William Freeborne of HUD and Greg Ralph of Dietrich Industries for their assistance and guidance throughout the project.

The principal author of this report is Nader R. Elhadj, P.E., with technical review provided by Jay Crandell, P.E. Administrative support was provided by Lynda Marchman, Mary Ellen Howard, and Donna Woodhurst.

Disclaimer

While the information in this document is believed to be accurate, neither the authors, nor reviewers, nor the U.S. Department of Housing and Urban Development of the U.S. Government, nor Dietrich Industries, Inc., nor the National Association of Home Builders, nor the NAHB Research Center, Inc., nor any of their employees or representatives makes any warranty, guarantee, or representation, expressed or implied, with respect to the accuracy, effectiveness, or usefulness of any information, method, or material in this document, nor assumes any liability for the use of any information, methods, or materials disclosed herein, or for damages arising from such use.

The U.S. Government does not endorse products or manufacturers. Trade or manufacturers names appear herein solely because they are considered essential to the object of this report.

The contents of this report are the views of the contractor and do not necessarily reflect the views or policies of the U.S. Department of Housing and Urban Development or the U.S. Government.

Foreword

For centuries home builders in the United States have made wood their material of choice because of its satisfactory performance, abundant supply, and relatively low cost. However, over the past few years, lumber prices have been experiencing a marked upward trend. In addition, builders also find themselves facing unpredictable fluctuations in lumber prices and concerns with lumber quality. The end result is that home builders and other providers of affordable housing are seeking alternative building materials and methods.

Use of cold-formed steel framing (CFS) in the residential market has increased over the past several years. However, its use remains very limited, partly because steel has not been integrated into the conventional home framing system. Cold-formed steel is particularly suitable for residential floor systems. Conventional floor systems are usually constructed of expensive, old growth lumber to meet the loading and span requirements. Therefore, residential floor construction represent an opportunity to cost-effectively improve resource utilization by integrating steel framing into otherwise conventional wood-frame houses.

The *Builders' Guide to Residential Steel Floors* provides builders, code officials, homeowners, and design professionals the necessary information required to use steel floor joists in typical residential construction.

This publication was developed under sponsorship of the U.S. Department of Housing and Urban Development (HUD) through a cooperative agreement with the National Association of Home Builders (NAHB) and Dietrich Industries, Inc.

Susan M. Wachter
Assistant Secretary for Policy
Development and Research

Table of Contents

1	Introduction to Residential Steel Floors.....	1
	Why Steel Floor Framing?.....	2
	Getting Started With Steel Framing.....	3
	The Basics: Construction Details and Terms.....	3
	Tools and Fasteners.....	5
	Training.....	6
	Availability, Purchasing, and Handling.....	7
	Technical Resources and Assistance.....	8
	References.....	10
2	Tools and Fasteners.....	11
	Introduction.....	11
	Cutting and Punching Tools.....	12
	Bending Tools and Clamps.....	12
	Fastening Methods and Tools.....	12
	Screws.....	14
	Drive Pins and Nails.....	21
	Bolts.....	21
	References.....	22
3	Steel Material Properties.....	23
	Introduction.....	23
	Types of Cold-Formed Steel.....	23
	Physical Dimensions of Steel Floor Framing Members.....	24
	Material Thickness, Bend Radius, and Yield Strength of Steel Framing Members.....	25
	Corrosion Protection of Steel Framing Members.....	26
	Web Holes in Steel Floor Framing Members.....	29
	Cutting, Notching, and Hole Patching of Steel Floor Framing Members.....	32
	Web Stiffeners for Steel Floor Framing Members.....	34
	Clip Angles.....	35
	References.....	36
4	Floor Construction.....	37
	Introduction.....	37
	Applicability Limits.....	37
	Foundation Preparation.....	38
	Basic Floor Framing Connections.....	39
	Floor Joist Span.....	48
	Bracing of Steel Floor Joists.....	53
	Web Stiffeners.....	57
	Floor Cantilevers.....	59
	Splicing of Steel Floor Framing Members.....	62
	Framing of Floor Openings.....	63
	Framing Stairwells.....	64
	Non-Load Bearing Walls Parallel to Joists.....	65
	References.....	66

5 Trade Installations.....	67
Introduction.....	67
Floor Finishes.....	67
Plumbing.....	68
Electrical.....	69
HVAC Systems and Duct Work.....	70
Insulation.....	71
References.....	72
6 General Recommendations.....	73
Introduction.....	73
Floor Joist Installation.....	73
Floor Sheathing Application.....	75
Curved Floors.....	78
Fire Safety.....	78
Fire and Draft Stops.....	79
Recommended Construction Methods for Controlling Sound.....	79
Vibration Control.....	80
Construction Guidelines.....	80
References.....	84
Appendix A - Definitions.....	A-1

List of Tables

Table 2.1: Typical Fasteners Used with Residential Steel Floor Framing.....	14
Table 2.2: Self-Drilling Screw Selection Chart.....	15
Table 2.3: Body Diameter.....	16
Table 3.1: Cold-Formed Steel Floor Member Sizes.....	25
Table 3.2: Thickness and Bend Radius of Cold-Formed Steel Floor Members.....	26
Table 3.3: Galvanic Corrosion Rate of Zinc Coupled to Other Common Metals.....	27
Table 3.4: Standard Hole Dimensions and Spacing in Floor Joist Webs.....	31
Table 3.5: Folded Hole Dimensions and Spacing in Floor Joist Webs.....	31
Table 4.1: Applicability Limits.....	38
Table 4.2: Basic Fastening Schedule.....	39
Table 4.3: Floor to Foundation or Bearing Wall Connection Requirements.....	40
Table 4.4: Allowable Spans for Cold-Formed Steel Floor Joists - Single Spans.....	50
Table 4.5: Allowable Spans for Cold-Formed Steel Floor Joists - Multiple Spans.....	51

List of Figures

Figure 1.1:	Steel Floor Framing	3
Figure 1.2:	Steel Floor Framing Terminology	4
Figure 1.3:	Typical Steel Floor Framing Tools	5
Figure 2.1:	Recommended Tools for Use with Residential Steel Floor Framing	11
Figure 2.2:	Screw Length Measurement	16
Figure 2.3:	Screw Grip Range	17
Figure 2.4:	Head Types	18
Figure 2.5:	Drive Types	19
Figure 2.6:	Screw Attachment Steel-To-Steel Connection	20
Figure 2.7:	Screw Attachment Floor Sheathing-To-Steel Connection	20
Figure 3.1:	C-Shaped Member Dimensions	24
Figure 3.2:	Track Section Dimensions	24
Figure 3.3:	Standard Web Hole in a Floor Joist	29
Figure 3.4:	Folded Web Hole in a Floor Joist	30
Figure 3.5:	TradeReady® Joist Rim Track	30
Figure 3.6:	Standard Web Hole Patch	33
Figure 3.7:	Folded Web Hole Patch	33
Figure 3.8:	Web Stiffener Detail	34
Figure 3.9:	TradeReady® Joist Web Stiffener	35
Figure 4.1:	Steel Floor to Foundation Connection Detail	41
Figure 4.2:	Steel Floor to Wood Sill Connection Detail	41
Figure 4.3:	Steel Floor to Load Bearing Wall Connection Detail	42
Figure 4.4:	Steel Floor to Double 2x Wood-Top-Plate Connection Detail	42
Figure 4.5:	Steel Floor to Single 2x Wood-Top-Plate Connection Detail	43
Figure 4.6:	TradeReady® Floor System to Concrete Masonry Unit Connection Detail	43
Figure 4.7:	Steel Floor to Foundation - Sidewall Connection Detail	44
Figure 4.8:	Joist-to-Steel Beam Connection Detail	45
Figure 4.9:	Joist-to-Steel Wall Connection Detail	45
Figure 4.10:	Steel Floor to Crawl Space Connection Detail	46
Figure 4.11:	Steel Joist-to-Interior Load-Bearing Steel Stud Connection Detail	47
Figure 4.12:	Single Span Joist	48
Figure 4.13:	Multiple Span Joist	48
Figure 4.14:	Location of Intermediate Supports	49
Figure 4.15:	Continuous Joist Span Supported on Interior Load Bearing Wall Detail	52
Figure 4.16:	Lapped Joist Supported on Interior Load Bearing Wall Detail	52
Figure 4.17:	Sheathing Installation Detail	53
Figure 4.18:	X-Bracing Detail	54

List of Figures (continued)

Figure 4.19:	Solid Blocking Detail	55
Figure 4.20:	Solid Blocking Connection Detail	55
Figure 4.21:	Solid Blocking Alternate Connection Detail	55
Figure 4.22:	TradeReady® Pre-Fabricated Bracing	56
Figure 4.23:	Gypsum Board Bracing Bottom Flanges	56
Figure 4.24:	Web Stiffener Connection Through Flanges	57
Figure 4.25:	Web Stiffener Connection Through Clip Angles	58
Figure 4.26:	TradeReady® Joist to Rim Track Connection with Built-in Stiffener	58
Figure 4.27:	Floor Cantilever to Foundation Connection Detail	59
Figure 4.28:	Floor Cantilever to Wood Sill Connection Detail	59
Figure 4.29:	Floor Cantilever to Load Bearing Wall Connection Detail	60
Figure 4.30:	Second Floor Cantilever Connection Detail	60
Figure 4.31:	Track Splice Detail	62
Figure 4.32:	Floor Opening Detail	63
Figure 4.33:	Floor Header to Trimmer Connection Detail	64
Figure 4.34:	TradeReady® Floor System Opening Detail	64
Figure 4.35:	Steel Interior Non-Load Bearing Wall Parallel to Joist	65
Figure 4.36:	Wood Interior Non-Load Bearing Wall Parallel to Joist	65
Figure 5.1:	Drain Pipe Installation	68
Figure 5.2:	Electrical Wires Through Floor Joists	69
Figure 5.3:	Electrical Wires Through Floor Joists and Rim Track	69
Figure 5.4:	Round Duct Through Joists with Folded Web Openings	70
Figure 5.5:	Installation of Batt Insulation Between CFS Joists	72
Figure 6.1:	Floor Joist to Double 2x Top Plates	73
Figure 6.2:	TradeReady® Rim Track	74
Figure 6.3:	Fastening Track to Joist	75
Figure 6.4:	Fastening Panel Ends	76
Figure 6.5:	Fastening Sheathing to Steel Joists	77
Figure 6.6:	Screw Installation	83

Introduction To Residential Steel Floors

For decades, people have used steel in the construction of bridges and buildings, in the automotive industry, machinery, and other products because of its strength, fire protection qualities, and durability. Being one of the most versatile of building materials, steel has experienced a steady growth in the commercial construction. Nationwide, home builders and homeowners are recognizing the many benefits steel has to offer the residential market. The steel that is predominantly used for residential framing is cold-formed steel. Steel is gaining acceptance among home builders and homeowners alike due to advantages such as cost-effectiveness, dimensional stability, noncombustability, termite resistance, durability, high strength to weight ratio, and recycleability.

The *Builders Guide to Residential Steel Floors* is provided as a guideline to facilitate the appropriate use of cold-formed steel floor framing in the construction of conventional one- and two-family residential dwellings, townhouses, and multifamily dwellings. The provisions in this document were developed by applying accepted engineering practices, test results of steel floor assemblies, and other published reports, technical bulletins, and manufacturer data. However, users of this document should verify its compliance with local code requirements and seek any necessary regulatory approvals prior to use. The user is advised to refer to applicable building code requirements for technical issues beyond the scope of this document and when engineered design is called out.

The first three chapters of this document provide an overview of cold-formed steel framing, including its advantages, technical resources, tools and fasteners, and material properties. The overview has many helpful tips and guidance, particularly for first timers. Builders and contractors must understand the strengths and weaknesses of the material they are using. They must also know how to cut, trim, measure, mark, and install steel framing members. Steel framers must know how to order steel members, how to select the proper tools, and how to fasten framing members together. While many of these considerations are best learned by practice, the transition between wood and steel floor framing can be rather easy with the proper guidance and planning.

Chapters 4 and 5 of this document describe how to construct cold-formed steel floors and related sub-trade installations. Chapter 6 provides general recommendations and construction guidelines that are gathered from experienced steel framers. The intent of that chapter is to provide steel framers with good practices that could save them time, material, and frustration.

Why Steel Floor Framing?

A builder should consider many factors before attempting to build a steel-framed-floor for the first time. Builders who have included steel framing in their toolbox of tricks frequently mention the following:

Tip #1 Plan to spend extra time in the first few jobs to “work out the kinks.”

Tip #2 “Start off simple”. Avoid using steel for the entire building the first time. Steel is more cost-effective and practical in certain applications such as floor framing and interior walls.

Tip #3 Obtain training and advice with respect to tools, fasteners, and other details prior to beginning your first serious job.

All materials have advantages and disadvantages that affect cost, constructability, consumer perception, structural performance, and durability. A builder must be aware of these issues to provide the best possible product, on-time and within budget. Some commonly reported qualities and benefits of steel framing are:

Price Stability: Steel prices have been relatively consistent over the past decade, unlike traditional wood materials that have experienced erratic price fluctuations.

Consistent Quality: Steel does not contain knots, twists, or warps that are commonly found in lumber. It is manufactured to tolerances that produce dimensionally and structurally consistent members.

Design Flexibility: Steel floor framing members come in a variety of sizes and thicknesses enabling the designer to meet specific load requirements economically.

Ease of Installation: Floor joists are lightweight and quickly installed. Holes are pre-formed simplifying the installation of plumbing, electrical, and mechanical lines and components. Steel joists are ordered cut to length thus reducing the time required to construct steel floors. However, the speed of installation is highly dependent on the experience of the installer, the proper selection of tools, and the details of a particular application.

Light Weight: Steel members weigh as much as 40 percent less than wood members, reducing total building and seismic loads.

Code Compliance: Cold-formed steel framing is code approved. Its non-combustibility and high strength allow its use in up to 6-story construction.

Common Appearance: Once exterior and interior finishes are installed, a wood and a steel house are indistinguishable from each other.

Resistance to Termites and Pests: Steel framing is impervious to termites and other wood-destroying insects.

Getting Started With Steel Floor Framing

The Basics: Construction Details and Terms

A steel-framed floor is nearly identical to conventional wood floor framing. A typical steel floor system, components, and terminology are shown in Figures 1.1 and 1.2.

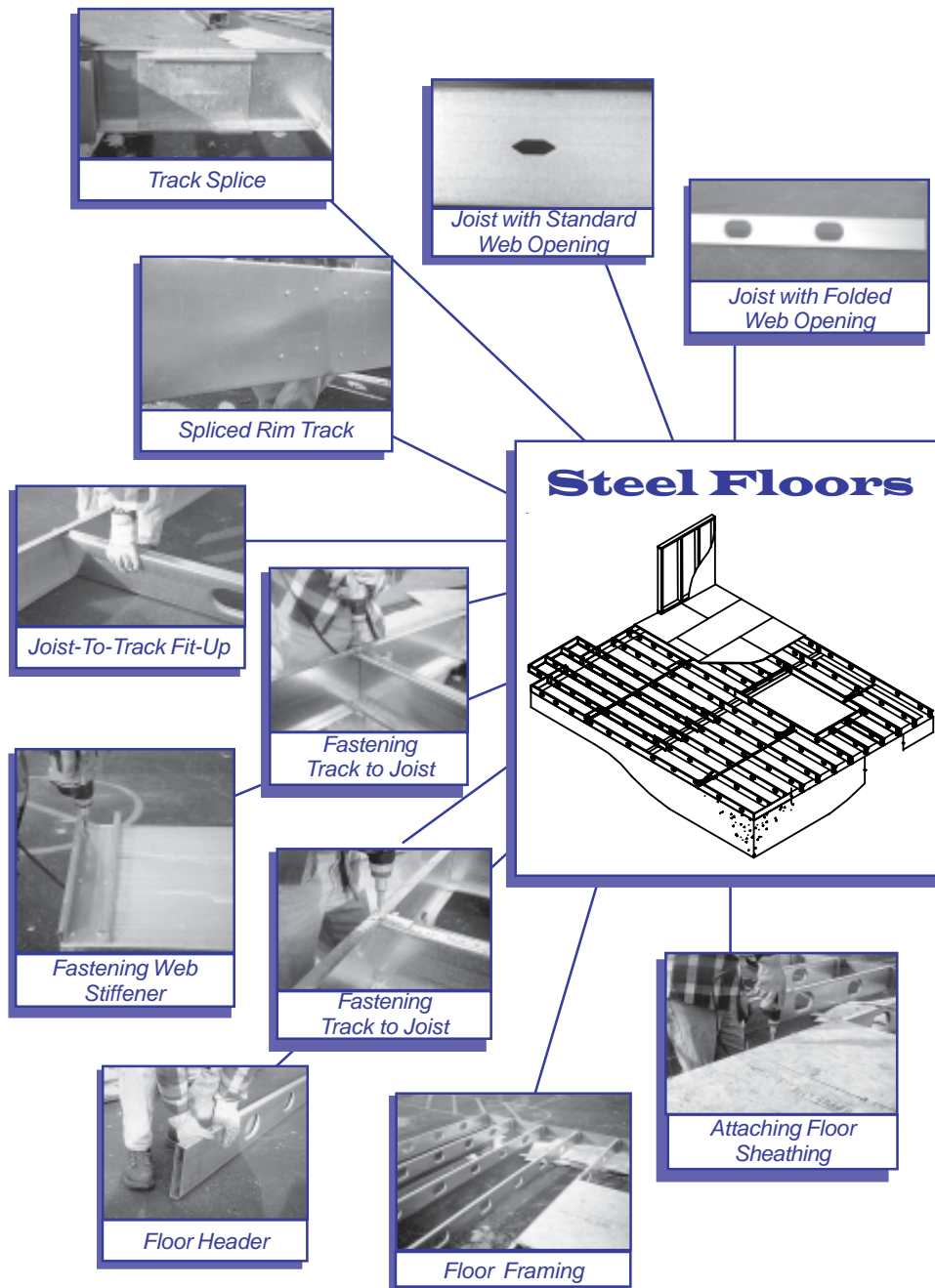

Figure 1.1. Steel Floor Framing

Builders' Guide to Residential Steel Floors

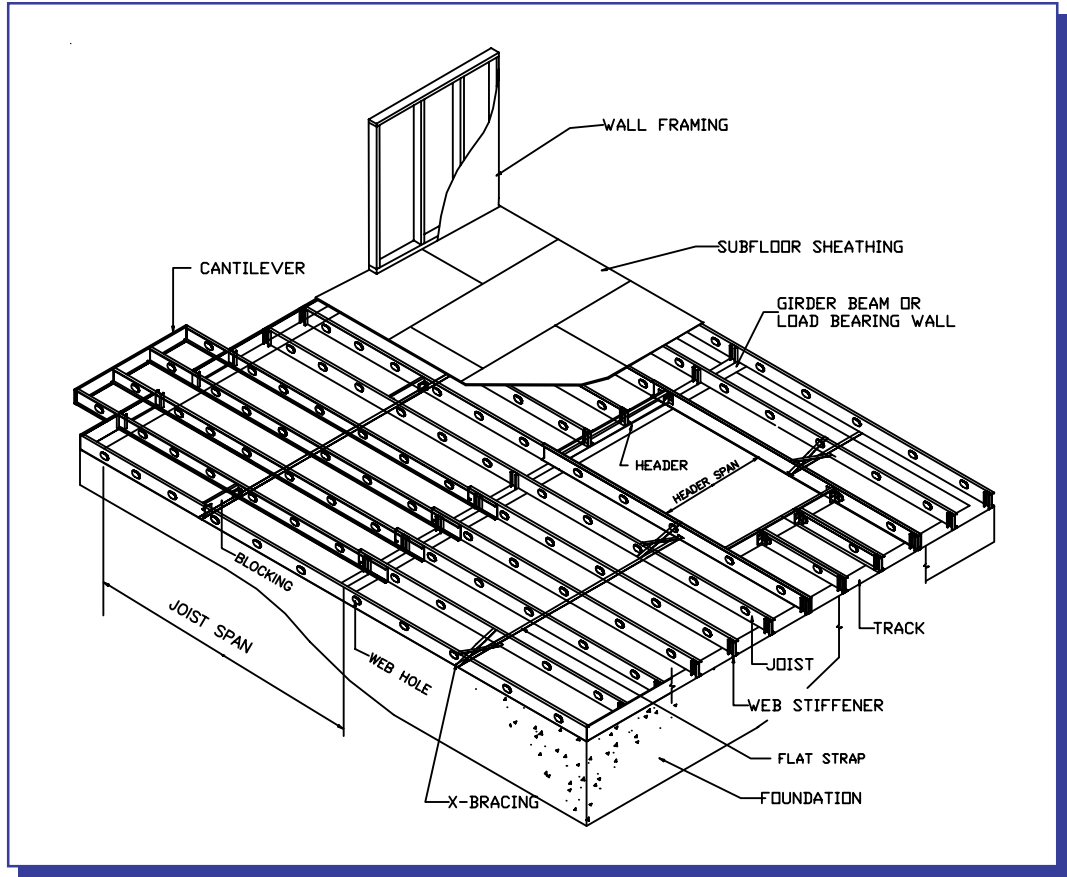

Figure 1.2. Steel Floor Framing Terminology

A list of definitions used in this guide is found in Appendix A

Tools and Fasteners

Proper tools and fasteners are also essential to the success of any job. Before starting a steel framing job, the correct tools and fasteners are required. Figure 1.3 shows the different tools and fasteners required for steel floor framing.

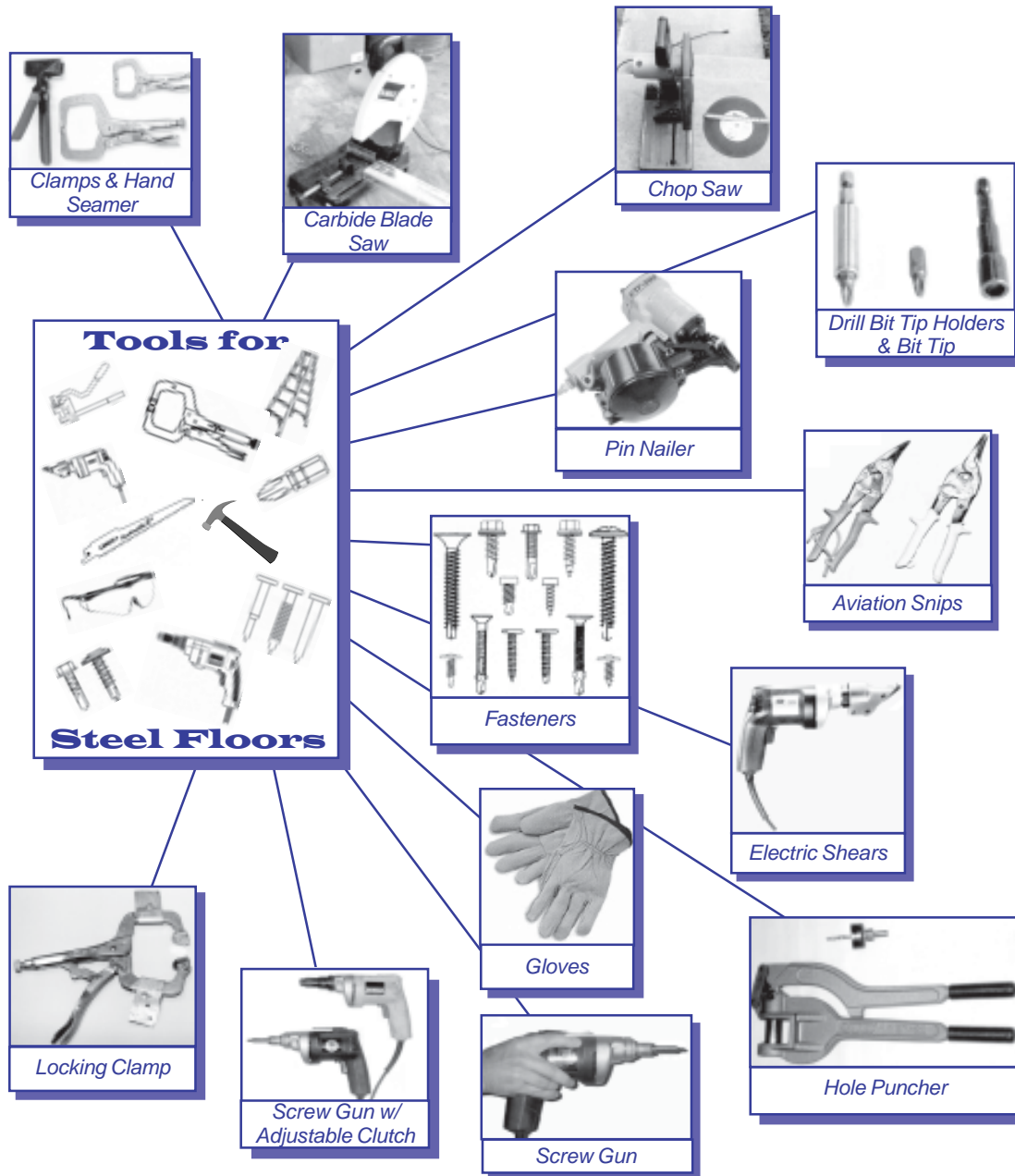

Figure 1.3. Typical Steel Floor Framing Tools

Training

As with any new product or process, it is essential to become acquainted with steel framing in order to be successful. Therefore, framers should be properly trained. As shown below, several training programs are available to assist with that need.

NASFA Residential Steel Framing National Training Curriculum

The National Training Curriculum is a standardized manual that provides clear, concise, step-by-step, illustrated framing techniques and procedures for use by experienced and novice framers.

Industry Training Programs

Industry organizations have begun implementing regional training programs to meet the need for residential steel framers.

- Home Builders Institute:
The Educational Arm of the NAHB
- AFL-CIO Building Construction Trades Department
- Associated Builders and Contractors
- Green Schools
- LGSEA
- NAHB Research Center:
The Research Arm of the NAHB
- USS-POSCO Industries Residential Steel Framing Center

Vocational and Technical Programs

These educational institutions use the National Training Curriculum or other training material in their construction training programs.

- Ivy Tech Training Center
East Chicago, IN
- Orange Coast College
Costa Meca, CA
- USS-POSCO Industries
Residential Steel Framing
Center
Pittsburg, CA

Training Manuals and Publications

Residential Steel Framing National Training Curriculum,
☎ (202) 269-2955, www.steel framingalliance.com

Steel Framed House Construction Training Manual
Steel Framed Housing – A “Hands On” Guide for Sub-Contractor Training Providers
BHP Steel, Sheet and Coil Products Division ☎ (202) 957-1177

How To Guide and Resource Catalog for Residential Steel Framing
☎ (202) 269-2955, www.steel framingalliance.com

Availability, Purchasing, and Handling

Cold-formed steel is generally supplied through (1) steel-framing manufacturers; (2) commercial building suppliers (i.e., roll-formers); and (3) home-improvement centers. Cold-formed steel is available in many sizes, thicknesses, shapes, and strength (yield strength). However, the choices are simplified in Chapters 3 and 4 and steel members may be specified using the simple designation system used in those chapters. Most steel suppliers can deliver standardized or customized steel components that are cut to length. In any case, the manufacturer's catalogs should be consulted prior to placing an order or designing a project. Most steel suppliers produce informative technical catalogs for their products. Prices of steel framing components vary from one supplier to another and from one region to another. However, steel suppliers give substantial discounts for truckload quantities.

Steel Tip

Select a local steel supplier whenever possible to minimize cost.

Steel Tip

Arrange to have a forklift at the job site to off-load the steel.

Builders should always try to select local steel distributors to minimize shipping cost and down time whenever additional framing components are needed. Steel suppliers typically use flat bed trucks or trailers to deliver steel to job sites. The steel components come in bundles or on pallets. Bundles are typically 2 feet wide, 2 feet high, and the length of the material. A forklift can handle most unloading jobs quite easily; however, care should be taken not to damage unusually heavy or long bundles of materials.

A list of roll formers, steel manufacturers and steel suppliers is available through the steel hotline 1.800.79.STEEL by ordering the North American Steel Framing Alliance's (*NASFA Residential Steel Construction Directory* [1]. *Metal Home Digest* and *Metal Construction News* compile a list similar to that of NASFA's [2][3].

Buying steel floor framing is not much different than buying traditional floor framing material. A steel supplier should be able to handle your order efficiently if you communicate clearly what you need. Again, the steel member designation found in this guide or the manufacturer's literature should be used when placing an order.

One of the easiest ways to simplify steel floor framing is to plan your cut list carefully. First of all, start simple by picking an easy first job. The steel supplier can often assist in doing a take-off and help to develop a cut-list. However, it is best for the builder or framer to learn to do this efficiently.

Steel is typically priced per lineal foot (or by weight) unlike wood that is priced per board foot. Therefore, be careful with your take-off units. It is also recommended that you order at least 10% more material than your cut list requires for your first steel project—that way you won't delay your project should you run into problems. Don't forget to consider screws, grommets, and other items affecting subtrades. These materials are frequently ordered through specialty suppliers, but can often be found in typical builder supply shops.

Technical Resources and Assistance

Hot Line

A residential steel hotline is set up by the North American Steel framing Alliance (NASFA) to provide “on demand” advice to builders, homeowners, engineers, architects, code officials, and others who are interested in framing with cold-formed steel. The hotline provides three services: (1) distributes informational and technical papers, publications, and reports about steel framing, (2) provides answers to common technical and framing questions, problems, and concerns regarding steel framing, and (3) helps identify local steel framing suppliers. The steel hot line utilizes the NAHB Research Center technical staff to answer caller questions. The steel hotline can be reached Monday through Friday, 9:00 am to 5:00 pm EST, at (800) 79-STEEL.

Publications

- *Prescriptive Method for Residential Cold-Formed Steel Framing*
Available through:
NAHB Research Center ☎ (800) 638-8556, www.nahbrc.org
North American Steel Framing Alliance
☎ (800) 79-STEEL, www.steel framingalliance.com
U.S. Department of Housing and Urban Development (HUD)
☎ (800) 245-2691, www.huduser.org
- *Residential Steel Framing Handbook*, By R. Scharff
Available through: McGraw-Hill ☎ (800) 822-8158,
www.mcgraw-hill.com
- *Residential Steel Framing Construction Guide*,
By E.N. Lorre
Available through: Aegean Park Press ☎ (714) 586-8811
- *Steel-Framed Residential Construction: Demonstration Homes*
Available through: NAHB Research Center ☎ (800) 638-8556,
www.nahbrc.org
- *Low-Rise Residential Construction Details, RG-934*
Residential Steel Beam and Column Load/Span Tables, RG-936
Fasteners for Residential Steel Framing, RG-933
Available through: North American Steel Framing Alliance
☎ (800) 79-STEEL, www.steel framingalliance.com

Steel Tip

Call
1(800)79-STEEL
for framing and
technical questions.

Trade and Professional Associations

North American Steel Framing Alliance (NASFA)
1726 M Street, NW, Suite 601
Washington, DC 20036-4523
☎ (202) 785-2022
Fax: (202) 785-3856
www.steel framingalliance.com

Light Gauge Steel Engineering Association (LGSEA)
2017 Galbraith Drive
Nashville, TN 37215
☎ (615) 279-9251
FAX: (615) 385-5045
www.LGSEA.com

NASFA's National Cost Reduction Center
☎ (909) 506-6008
Fax: (909) 506-6108

NASFA's Training and Regional Alliance Development
☎ (808) 485-1400
Fax: (808) 485-1500

Hawaii Steel Alliance
☎ (808) 485-1400
Fax: (808) 485-1500
www.hawaii steel.com

Midwest Steel-Framing Alliance
☎ (219) 763-6303
Fax: (219) 763-2653

Southeastern Steel-Framing Alliance (SESFA)
☎ (904) 479-7208
Fax: (904) 478-7309

Magazines and Newsletters

How To Guide and Resource Catalog for Residential Steel Framing,

- ☎ (202) 269-2955, www.steel framingalliance.com
- LGSEA Tech Notes ☎ (615) 279-9251, www.LGSEA.com
- LGSEA Newsletter ☎ (615) 279-9251, www.LGSEA.com
- CCFSS News ☎ (573) 341-4471, www.umn.edu/~ccfss
- The Steel Home Advisor ☎ (202) 452-7100, www.steel.org
- Metal Home Digest ☎ (847) 674-2200, www.moderntrade.com
- Metal Construction News ☎ (847) 674-2203, www.moderntrade.com

Roll-former

TradeReady® Joist
 DIETRICH Industries, Inc.
 500 Grant Street, Suite 2226
 Pittsburgh, PA 15219
 ☎ (412) 281-2805
 FAX: (412) 281-2965
www.dietrichindustries.com

Steel Tip

For a complete list of roll formers in your region, call 1(800) 79-STEEL.

Testing and Research Facilities*

NAHB Research Center, Inc.
 400 Prince George's Blvd.
 Upper Marlboro, MD 20774
 ☎ (301) 249-4000
 FAX: (301) 218-8827
www.nahbrc.org

Center for Cold-Formed Steel Structures (CCFSS)
 University of Missouri-Rolla
 Rolla, MO 65409-0030
 ☎ (573) 341-4471
 FAX: (573) 341-4476
www.umn.edu/~ccfss

**There may be other testing facilities in your local area.*

Code Recognition

Cold-formed steel framing is recognized in the three major model building codes. The ICC One and Two Family Dwelling Code and the International Residential Code (IRC) contain prescriptive requirements for steel floor framing, while the other codes (BOCA, UBC, SBC, and IBC) contain performance requirements for steel floor framing.

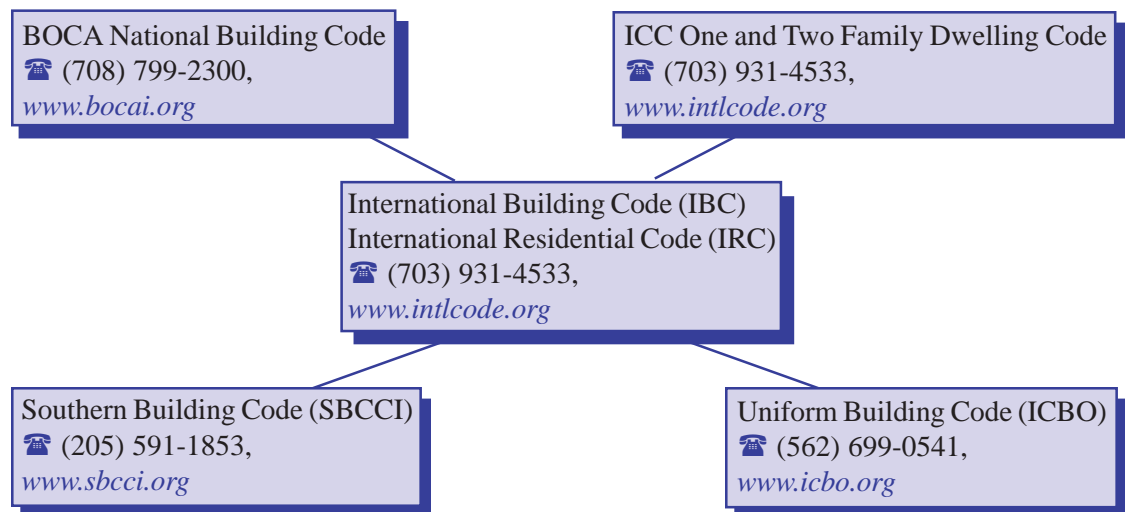

Builders' Guide to Residential Steel Floors

References

- [1] *1999 Residential Steel Construction Directory*, Publication NT12.99, North American Steel Framing Alliance (NASFA), Washington DC, 1999.
- [2] Metal Home Digest's 4th Annual Residential Building Products Directory, *Metal Home Digest*, Skokie, IL, Jan.-Feb., 1998.
- [3] Building Systems Product File and Directory, *Metal Construction News*, Skokie, IL, January, 1998.

Tools and Fasteners

Introduction

In Chapter 1, a basic overview of tools and fasteners was provided. In this chapter, specific details and guidance are given to promote installation efficiency and performance.

Installation of cold-formed steel (CFS) floor framing requires three basic steps: cutting, clamping and fastening. Tools for these steps are available at most lumberyards and hardware stores. Figure 2.1 provides a list of recommended tools for framing CFS floors. Other tools and fasteners are being used successfully by builders.

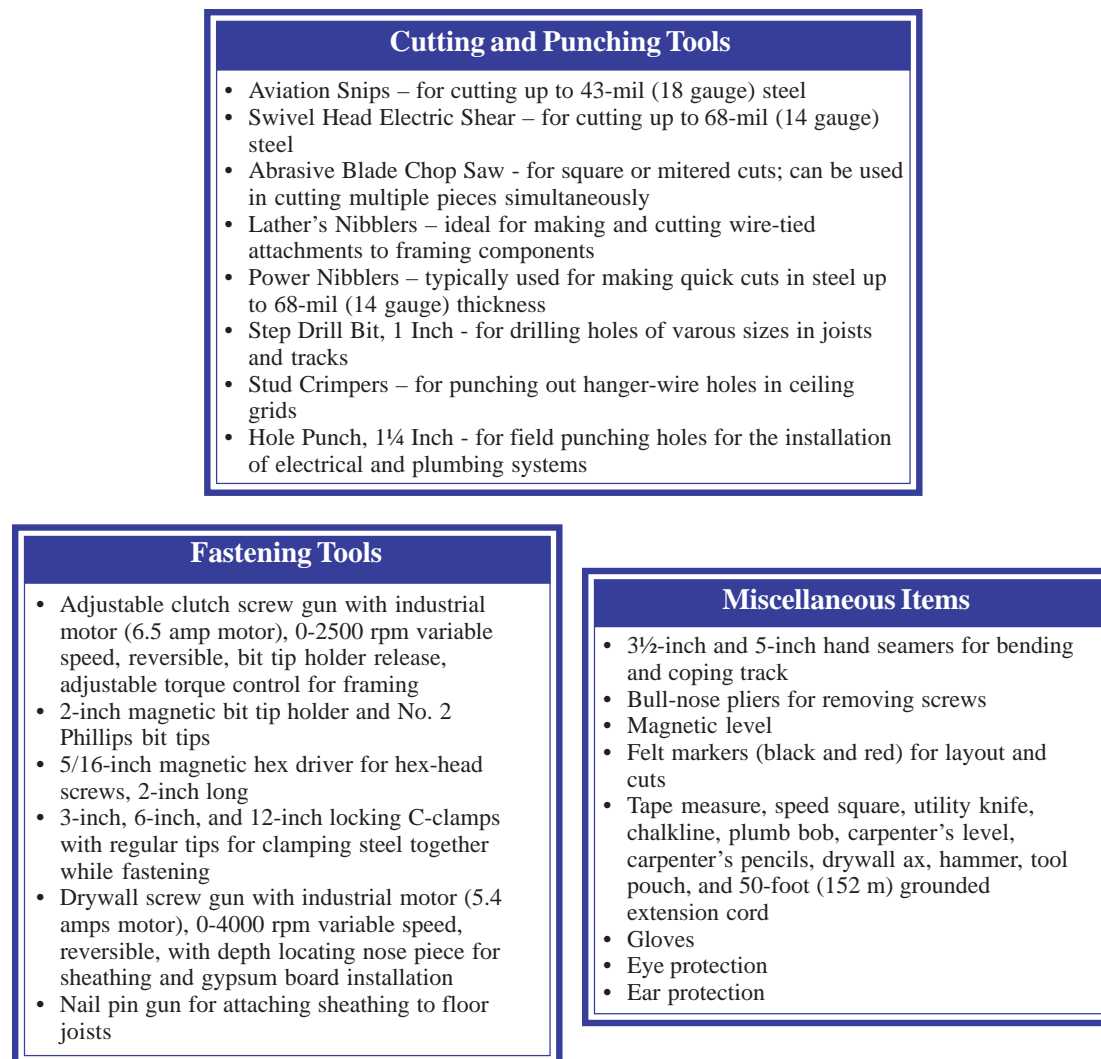

Figure 2.1. Recommended Tools for Use with Residential Steel Floor Framing

Cutting and Punching Tools

CFS floor joist framing members typically require minimum cutting because they can be ordered cut to length. Cutting tools are required to cut web stiffeners, straps, blocking, and framing members around openings. The following summarizes available cutting tools and their application:

- *Aviation Snips*. These are hand tools that cut steel thicknesses up to 43-mils (18 gauge). They are good for making minor cuts “on-the-go.”
- *Electric Power Shears*. A hand held tool used to cut steel thicknesses up to 68-mils.
- *Chop Saw*. A chop saw is the most efficient means of cutting steel members. It is a circular saw with an abrasive blade and is generally set up at a central location.
- *Lather’s Nibblers*. Ideal for making and cutting wire-tied attachments to framing components.
- *Power Nibblers*. Typically used for making quick cuts in steel up to 68-mil thickness.
- *Step Drill Bit*. For drilling holes of various sizes.
- *Stud Crimpers*. A hand-held tool used to punch out hanger-wire holes in ceiling grids.
- *Hole Punch*. A hand-held tool used to punch utility holes in steel members.
- *Circular Saws*. These are portable hand-held electric power tools with carbide tipped blades.
- *Plasma Cutter*. Electric tool that cuts the steel by melting it. The melting is accomplished by producing an arc where the probe is applied.
- *Portable Hydraulic Shear*. These are typically found in panelization plants. They use hydraulic force to leave a clean cut.

Other cutting tools such as cut-off saws, power bandsaws, portable power hacksaws, lather’s nippers, channel stud shears, and power nippers can also be used.

Bending Tools and Clamps

Hand seamers are the most common tools used by steel floor framers to bend steel members (such as web flanges for blocking). They are typically used for small bends and are often called “duck-billed pliers”. Press brakes are machines that bend steel lengths up to 10 feet (3 m). They are generally used in metal shops.

Locking C-clamps are essential tools for steel framers and come in variety of sizes. Locking C-Clamps are typically used to hold the steel pieces together during fastening.

Fastening Methods and Tools

Fastening Methods

Fastening CFS floor framing members can be accomplished using different methods and techniques. The most common methods of fastening steel to steel are accomplished by screwing, welding, clinching, and nailing. Self-drilling, tapping screws are the most prevalent fastener. Other fasteners, such as pneumatically driven fasteners, powder-actuated fasteners, and crimping can also be used. Screws are typically applied with a positive-clutch electric screw gun.

Steel Tip

Order steel joists cut to length to minimize field labor time.

Fastening Tools

Screw guns and pin nail guns are generally used for fastening steel floor components. Pneumatic screwdrivers (or air driven screw guns) are also used although they are still new to the steel framing market. Powder actuated tools are typically used to fasten steel members to concrete or to structural steel. Welding machines are frequently used in panelized steel systems. Clinching tools are also gaining popularity among panelized steel fabricators.

Screw Guns and Nail Guns

The screw gun is the primary tool for a steel framer. It is as important as the nail gun or hammer for a wood framer. A screw gun is an electric screwdriver and not a drill. The screw will spin only when pressure is applied against the screw tip. Cordless screw guns are also available and operate on battery power. Two types of screw guns are needed to frame steel floors:

- *Adjustable Torque/Clutch Screw Gun.* This type of screw gun has adjustable clutch and torque settings with and a maximum speed range of 0-2,500 rpm. It typically has a quick change bit chuck for bit tips and a reverse switch to remove screws if incorrectly installed. It is highly recommended.
- *Drywall Screw Gun.* Drywall screw guns are designed to attach plywood or gypsum board to steel. They should be industrial strength with a 0.5 amp motor and a maximum speed range of 0-4,000 rpm. They should be reversible and equipped with a removable, depth sensitive nosepiece for installing sheathing and gypsum board. Drywall screw guns should not be used for steel-to-steel connections because they do not have an adjustable clutch, run at high speeds, and often burn up the screw drill tips – a frustrating experience. They are designed primarily for sharp point screws.
- *Nail Pin Gun.* Nail pin guns are generally used to attach sheathing (such as plywood or OSB) to floor joists. They are not used for steel-to-steel connections. Nail guns have an advantage over screw guns in that they are faster. Nail pins are specially designed nails with a knurled surface to bite into the steel when it penetrates. Nail pin guns are essentially identical to pneumatic nailers used in wood framing.

Steel Tip

Make sure you are using the correct screw gun for each application.

Screws

Holes are not typically drilled in steel floor framing before installing the screws (a time consuming approach). Therefore, self-drilling self-tapping screws are the most common fasteners used to frame CFS floors. Screws are available in diameters ranging from #6 to #14, with #6 to #10 being the most common. Lengths typically vary from 1/2 inch (12 mm) to as much as 3 inches (76 mm) depending on the application. Screws are generally 3/8 inch (9.5 mm) to 1/2 inch (12.7 mm) longer than the thickness of the connected materials so that a minimum of three threads extend beyond the connected material. It is important that the drill point be as long as the material thickness being fastened to drill effectively. The correct fastener type and length for each application should be selected by consulting the screw manufacturer's specifications and catalogs. Table 2.1 provides a list of typical fasteners used with residential steel floor framing. The remainder of this section gives a detailed description of various screw options and characteristics.

Table 2.1. Typical Fasteners Used with Residential Steel Floor Framing

Application	Fastener
Steel-to-steel non-load bearing (less than 33 mils)	Minimum #6, sharp point, low-profile head
Steel-to-steel load bearing	Minimum #8, self-drilling, low-profile head where gypsum board or sheathing is to be installed; otherwise, a hex head can be used
Gypsum board to Floor Joists	Minimum #6, sharp point/self drilling, bugle-head screws. Sharp point screws for steel up to 33 mils (0.84 mm) and self-drilling point for thicker steel (a #6 sharp point screw may penetrate 43 mil steel with extra force applied)
Interior trim	#6 minimum, sharp point/pilot point, finish or trim-head screws. If wood blocking is installed use finishing nails
OSB/Plywood to Floor Joists	Minimum #8, sharp point/self drilling, bugle-head screw (1-15/16" long). Winged screws and pneumatic fasteners are also available
Steel to Poured Concrete and Concrete Block Surfaces	3/16" x 1-3/4" acron-slotted anchors

For SI: 1 inch = 25.4 mm, 1 mil = 0.025 mm.

Point Types

Two specific point types are commonly used:

1. Self-Drilling Screws are externally threaded fasteners with the ability to drill their own hole and form, or “tap”, their own internal threads without deforming their own thread and without breaking during assembly. These screws are used with 33-mil (20 gauge) steel or thicker. They are also used when fastening two or more pieces of steel of any thickness.

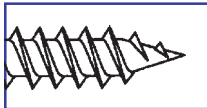
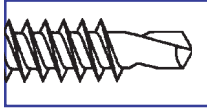

2. Self-Piercing (Sharp Point) Screws are externally threaded fasteners with the ability to pierce relatively thin steel material. They are commonly used to attach rigid materials, such as gypsum wall board, to 33-mil (20 gauge) or thinner steel.

Steel Tip

Drill point must be long enough to penetrate subflooring and steel joists prior to engaging threads into the subfloor. Otherwise, the screw threads will bind-up before the drill tip has penetrated the steel. This can cause floor squeaks and weaker connections.

For drill point screws, the point style will determine the total thickness of steel the screw is designed to drill through. The larger the point style number and the larger the screw diameter, the more material the screw is capable of penetrating. Screws should be selected based on the total steel thickness as shown in Table 2.2 [2]. While point styles 1, 4, and 5 are available, the most common are point styles 2 and 3.

Table 2.2. Self-Drilling Screw Selection Chart [2]

Point Style ¹	Nominal Screw Size ²	Total Thickness of Steel ³ (inch)
2	4	0.080 Max.
	6	0.090 Max.
	8	0.100 Max.
	10	0.110 Max.
	12 1/4"	0.140 Max. 0.175 Max.
3	6	0.090-0.110
	8	0.100-0.140
	10	0.110-0.175
	12	0.110-0.210
	1/4"	0.110-0.210

For SI: 1 inch = 25.4 mm.

¹Point style determines the recommended thickness of steel through which the screw may be driven (consult manufacturer data).

²Minimum screw size is dependent on the thickness of steel because the torque required to drive a screw increases with steel thickness.

³The combined thickness of all connected steel members.

Body Diameter

The body diameter of a screw is related to the nominal screw size as shown in Table 2.3. Most connections will be made with a minimum of #8 screw, except when attaching gypsum wall board using a #6 screw.

Table 2.3. Body Diameter

Number Designation	Nominal Diameter, d, in.*
0	0.0600
1	0.0730
2	0.0860
3	0.0990
4	0.1120
5	0.1250
6	0.1380
7	0.1510
8	0.1640
10	0.1900
12	0.2160
1/4"	0.2500

Length

The length of a screw is measured from the bearing surface of the head to the end of the point as shown in Figure 2.2. For example, the length of a flat or countersunk head is measured from the top of the head to the end of the point. A pan head screw length is measured from under the head (bearing surface) to the end of the point.

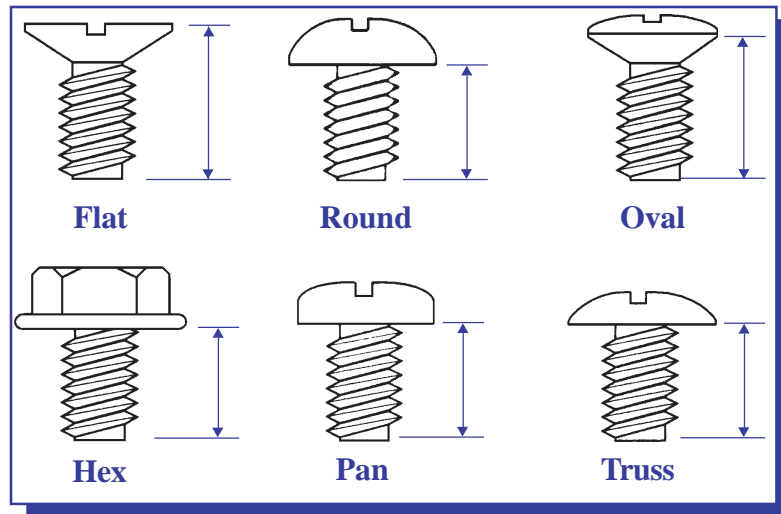

Figure 2.2. Screw Length Measurement

Reprinted with permission of the Light Gauge Steel Engineers Association. All rights reserved.

The length of self-drilling screws may require special consideration since some designs have an unthreaded pilot section or reamer with wings between the threads and the drill point as shown in Figure 2.3. These features may be necessary for certain applications such as applying wood sheathing to a steel floor joist. The long pilot point or reamer (see Figure 2.3) is required to allow the screw to drill through the material before engaging the threads. If the threads engage before the pilot hole is drilled completely, a gap may result in the connection. This can result in a squeaky floor or “screw-pops” through certain floor finish materials.

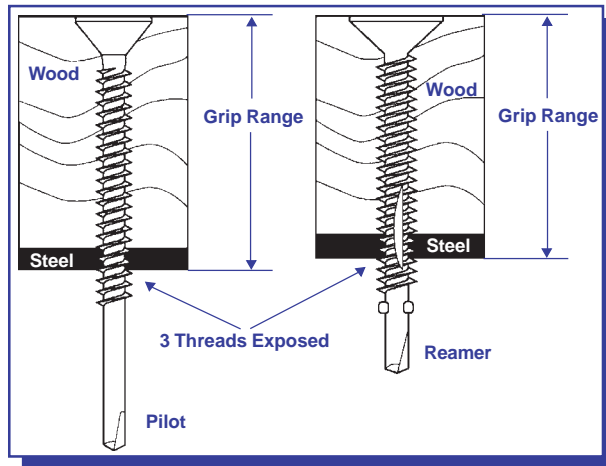

Figure 2.3. Screw Grip Range

Reprinted with permission of the Light Gauge Steel Engineers Association. All rights reserved.

Thread

Self-piercing and self-drilling screws intended for cold formed steel applications generally have a coarse thread (e.g., 10-16 x 5/8 HWH SD, would indicate a 10 diameter, 16 threads per inch, 5/8” length, hex washer head, self-drilling screw). There are also many self-drilling screws that have fine threads for use in thicker steel. Manufacturer recommendations should be followed.

Corrosion Resistance

Common platings for corrosion resistance include zinc (mechanical galvanizing), phosphate and oil, and zinc with a yellow dichromate finish (appearing gold in color). In addition, many specialty platings are given trade names by the manufacturer. Self-drilling screws are typically zinc plated and comply with 96-hour salt spray test (ASTM B633) [1].

Head Styles

Common head styles include flat, oval, wafer, truss, modified truss, hex washer head, pan, round washer and pancake. See Figure 2.4. Which style is specified may be determined by the application, preference and availability. However, hex head screws are typically used for heavier structural connections, round washer screws are typically used for general framing connections, low profile heads are used on surfaces to be finished with gypsum board, and bugle head screws are typically used to attach sheathing products.

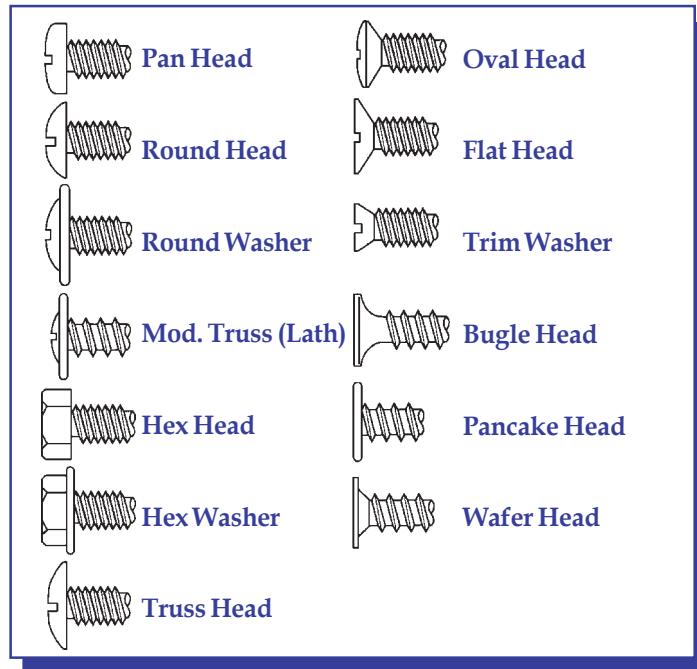

Figure 2.4. Head Types

Reprinted with permission of the Light Gauge Steel Engineers Association. All rights reserved.

Drive Types

Drive types are usually determined by availability and preference. Common drive types are shown in Figure 2.5.

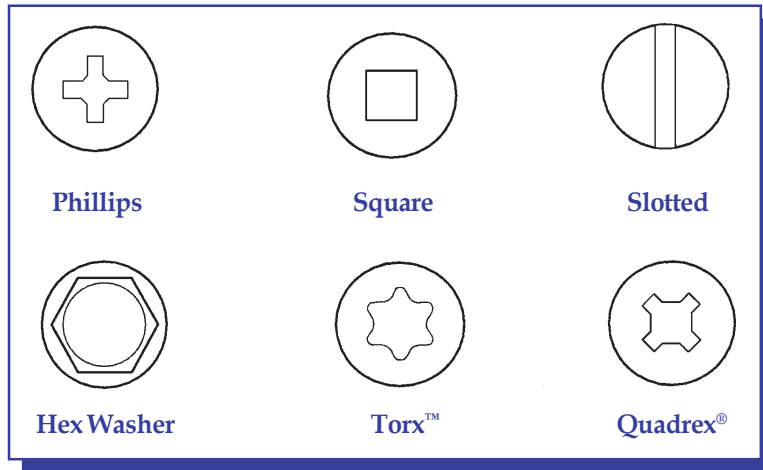
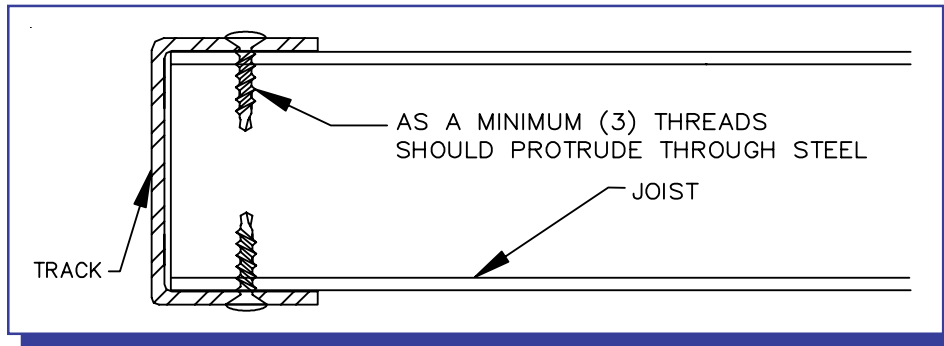

Figure 2.5. Drive Types

Reprinted with permission of the Light Gauge Steel Engineers Association of author. All rights reserved.

Screw Requirements

For all connections, screws should extend through the steel a minimum of three exposed threads as shown in Figures 2.6 and 2.7. Screws should penetrate individual components of a connection without causing permanent separation between the components. Screws should be installed in a manner such that the threads and holes are not stripped. Self-drilling tapping screws should have a Type II coating in accordance with ASTM B633 [1] or equivalent corrosion protection.



**Figure 2.6. Screw Attachment
Steel-To-Steel Connection**

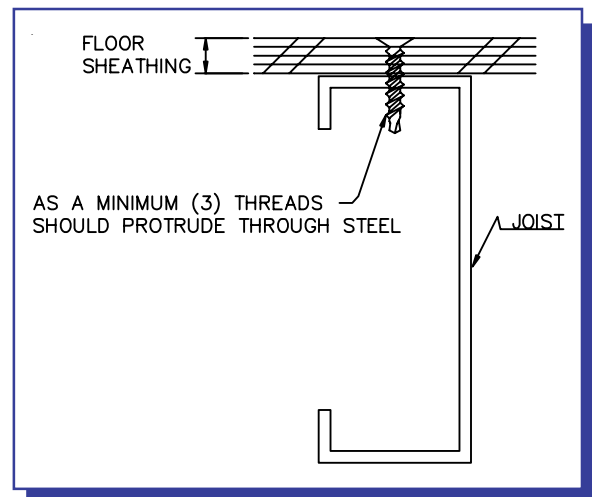

**Figure 2.7. Screw Attachment
Floor Sheathing-To-Steel Connection**

Steel Tip

No. 8, 1/2-inch self-drilling, tapping screws are typically used for 33 and 43 mil steel-to-steel-connections.

Steel Tip

No. 8, 3/4-inch self-drilling, tapping screws with pilot points are typically used to fasten OSB or plywood to steel floor framing.

Drive Pins and Nails

Pneumatic pins and nails are specifically designed with spiral grooves or knurls on the nail shaft to penetrate and grip the steel. Similar to wood framing, drive pins and nails are used with airguns. Sub-flooring can be fastened to joists with drive pins. Care should be taken to follow manufacturer recommendations carefully to avoid problems such as squeaky floors.

Bolts

Bolts are not commonly used in cold-formed steel floor framing, except when required to anchor a floor to a concrete or masonry foundation. Anchoring a cold-formed steel floor to a foundation is generally accomplished in a manner similar to wood framing. The most common anchors used in steel floor construction are anchor bolts, mudsill anchors, anchor straps, mushroom spikes, and powder-actuated anchors. Bolts should meet or exceed the requirements of ASTM A307 [3]. Washers and nuts should be properly installed and tightened. Also, the distance from the center of the bolt hole to the edge of the connecting member should not be less than one and one-half bolt diameters.

References

- [1] ASTM B633-85 (1994) e1, *Standard Specification for Electrodeposited Coatings of Zinc on Iron and Steel*, American Society for Testing and Materials (ASTM), West Conshohocken, PA. 1994.
- [2] SAE J-78-1979, *Steel Self-Drilling Tapping Screws*, Society of Automotive Engineers, 1979.
- [3] ASTM A307-97, *Standard Specification for Carbon Steel Bolts and Studs, 60 000 PSI Tensile Strength*, American Society for Testing and Materials (ASTM), West Conshohocken, PA. 1997.

Steel Material Properties

Introduction

Structural steel members are divided into two main categories: 1) hot-rolled shapes and plates and 2) cold-formed steel. Cold-formed steel is made directly from steel sheets, strip, plates, or flat bars in roll forming machines or by press brake or bending brake operations. Roll forming is the most popular and versatile method.

Roll formers order hot-dipped galvanized coils from the steel mills. A slitter is used to cut the coils into strips or ribbons that are fed into the roll-forming machine on a spool. In the machine, steel is passed through a series of dies that bend the strips of steel into the desired shapes (such as 8-inch joist). These roll-forming machines are much like heavy-duty computer-controlled gutter machines used by roofing and guttering contractors. Some builders have purchased roll-forming machines to economize on material costs, storage, and scheduling.

The C-shaped section is the most commonly used shape in residential and commercial cold-formed steel construction. A typical C-shaped member consists of a web, a flange, and a lip. It is referred to as a *joist* in floor framing, a *stud* in wall framing, and a *rafter* in roof framing. C-shaped members can be ordered with or without holes (punchouts). Other cold-formed steel shapes are also used in floor framing such as flat straps, angles, plates, furring channels, and hat channels.

Most roll-formers mark their joist members for identification purposes. Labeling makes it easier for the end user to identify steel thickness, strength, and coating.

Types of Cold-Formed Steel

Steel floor joist members should be cold-formed to shape from structural quality sheet steel complying with the requirements of one of the following:

- ASTM A 653 [1]: Grades 33, 37, 40, & 50 (Class 1 and 3); or
- ASTM A 792 [2]: Grades 33, 37, 40, & 50A; or
- ASTM A 875 [3]: Grades 33, 37, 40, & 50 (Class 1 and 3); or
- Steels that comply with ASTM A 653 [1], except for tensile and elongation requirements, shall be permitted provided the ratio of tensile strength to yield point is at least 1.08 and the total elongation is at least 10 percent for a two-inch gage length or 7 percent for an eight-inch gauge length; or
- Other steels as approved by local building codes.

Physical Dimensions of Steel Floor Framing Members

Steel floors are generally constructed with steel joists having depths that range from 8 to 12 inches (203 to 305 mm) with a steel thickness from 43 mil to 97 mil (1.1 to 2.5 mm). The physical dimensions and thicknesses of steel floor joist members are shown in Figures 3.1 and 3.2 and Table 3.1. Members with different geometrical shapes should not be used with this guide without the approval of a design professional. Dimensional tolerances should be in accordance with ASTM C955 [4] for load bearing members and ASTM C645 [5] for non-load bearing members.

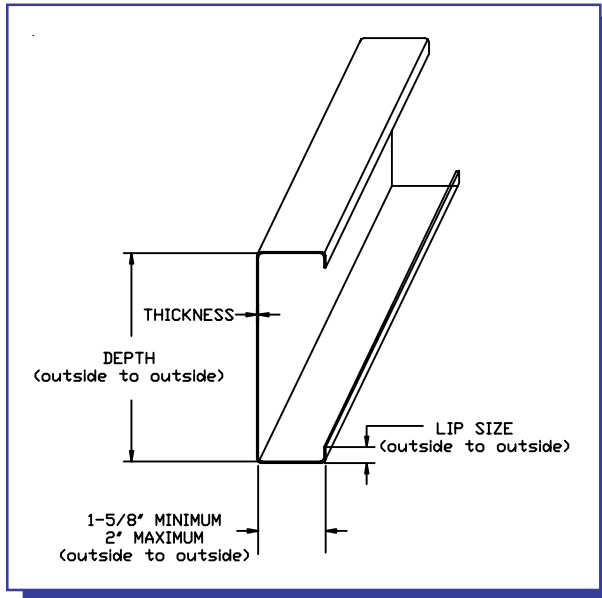

Figure 3.1. C-Shaped Member Dimensions

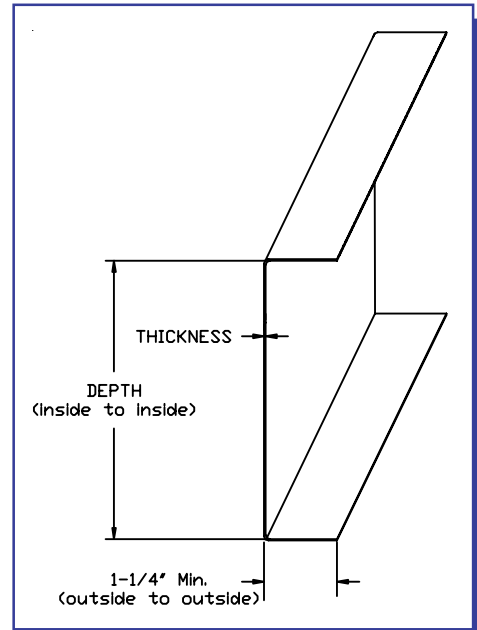

Figure 3.2. Track Section Dimensions

Table 3.1. Cold-Formed Steel Floor Member Sizes

Nominal Member Size	Industry Designator ¹	Web Depth (in.)	Minimum Flange Width (in.)	Maximum Flange Width (in.)	Minimum Lip Size (in.)
2 x 8 x 43	800S162-43	8	1.625	2	0.5
2 x 8 x 54	800S162-54	8	1.625	2	0.5
2 x 8 x 68	800S162-68	8	1.625	2	0.5
2 x 9 x 54	1000S162-54	9.25	1.625	2	0.5
2 x 9 x 68	1000S162-68	9.25	1.625	2	0.5
2 x 10 x 54	1000S162-54	10	1.625	2	0.5
2 x 10 x 68	1000S162-68	10	1.625	2	0.5
2 x 12 x 54	1200S162-54	12	1.625	2	0.5
2 x 12 x 68	1200S162-68	12	1.625	2	0.5
2 x 8 x 33 Track	800T125-33	8	1.25	2	N/A
2 x 8 x 43 Track	800T125-43	8	1.25	2	N/A
2 x 8 x 54 Track	800T125-54	8	1.25	2	N/A
2 x 9 x 54 Track	925T125-54	9.25	1.25	2	N/A
2 x 10 x 33 Track	1000T125-33	10	1.25	2	N/A
2 x 10 x 43 Track	1000T125-43	10	1.25	2	N/A
2 x 10 x 54 Track	1000T125-54	10	1.25	2	N/A
2 x 12 x 43 Track	1200T125-43	12	1.25	2	N/A
2 x 12 x 54 Track	1200T125-54	12	1.25	2	N/A

For SI: 1 inch = 25.4 mm.

¹ The designation system used by the Steel Stud Manufacturers Association (SSMA).

Material Thickness, Bend Radius, and Yield Strength of Steel Framing Members

The strength of cold-formed steel floor joists and other structural members increases tremendously with increased thickness. The thickness is typically designated with gauge, inches, or mils. The higher the gauge the thinner the steel thickness. The mil designation, for which each mil is equivalent to 1/1000 of an inch, is gaining popularity among builders, roll formers, and steel mills. The yield strength is also a very important characteristic of steel members (similar to the bending stress of wood that is qualified in terms of “grades” of lumber). In general, the higher the yield strength, the stronger the member. The yield strength of steel is the point where the steel starts to give in when subjected to additional load, but when this load is removed, the steel returns to its original shape without permanent deformation. Once the yield strength is exceeded, permanent deformation begins to occur. Steel yield strength is typically determined in accordance with ASTM A370 [6]. The uncoated material thickness (bare steel without the zinc coating), the inside bend radius, and the minimum yield strength of steel floor framing members are shown in Table 3.2.

Table 3.2. Thickness and Bend Radius of Cold-Formed Steel Floor Members

Designation (mils)	Minimum Steel Thickness (in.)	Reference Gauge Number	Maximum Bend Radius (in.)	Minimum Yield Strength ¹ (ksi)
33	0.033	20	3/32	33
43	0.043	18	3/32	33
54	0.054	16	1/8	33
68	0.068	14	1/8	33

For SI: 1 inch = 25.4 mm, 1 mil = 0.0254 mm, 1 ksi = 6.9 MPa.

¹ The yield strength is determined in accordance with ASTM A370 [6].

² Steel joists thicker than 43 mils may only be available in 50 ksi material.

Corrosion Protection of Steel Framing Members

Homeowners expect their homes to last for a lifetime or more. Therefore, it is critical that framing materials have the proper protection to provide this longevity. With steel, the proper protection comes in the form of galvanizing. Galvanizing is the process whereby steel is immersed into a bath of molten zinc to form a zinc coating.

Steel sheets, before being rolled into coils, are generally sent through a hot-dipped galvanizing process that applies a metallic zinc coating to protect the steel from rust. Coated steel, therefore, is designed not to rust while on the construction job site, during construction, or after construction. A protective barrier (i.e., zinc) on the surface that does not allow moisture to contact the steel prevents corrosion of steel framing members. Zinc galvanizing protects the steel by acting as a sacrificial coating and provides long-term integrity against rusting. If steel gets scratched, dented, cut, or punched, the coating will continue to protect the exposed area sacrificially. This reaction expands across the exposed steel and reseals the protective barrier.

The galvanizing process can apply a number of different coatings that vary in appearance and coating thickness. Three different types of coatings are commercially available for cold-formed steel:

Galvanized - This is the standard process of continuous coating with pure zinc. The finished coating provides good corrosion resistance and excellent sacrificial protection.

Galfan - This type of coating contains aluminum in addition to zinc. It has an improved corrosion resistance compared to galvanized coatings.

Galvalume - This type of coating contains higher percentage of aluminum and silicone is added. It provides a superior corrosion resistance compared to galvanized coatings. The degree of corrosion protection is measured by the coating weight (ounces per square foot) or by thickness (mils or microns) of the coating. A G60 coating for example, has a total weight of 0.60 oz/ft² (both sides) and a 0.51 mils nominal thickness per side.

Galvanized Steel in Contact with Building Materials

- **Contact with Other Metals**

An electrochemical reaction occurs between dissimilar metals or alloys that can cause corrosion of one metal and protection of the other when they are in direct contact. This reaction will only occur when the dissimilar metals are “connected” in an electrolyte medium (such as moisture). In normal indoor environments, moisture levels are usually very low and, consequently the galvanic action between dissimilar metals is much lower than those occurring in outdoor environments. Steel joist members are generally coated with aluminum/zinc alloy. Both zinc and steel will react adversely with brass and copper used for plumbing installations – this is known as a “galvanic reaction” or galvanic corrosion” and can lead to durability problems just like other forms of corrosion. Table 3.3 below provides the galvanic rate of zinc coupled to other common commercial metals based on outdoor atmospheric studies [7].

Table 3.3. Galvanic Corrosion Rate of Zinc Coupled to Other Common Metals

Coupled Alloy	Zinc Corrosion Rate
Mild steel	High
Stainless steel	Low
Brass	High
Bronze	High
Copper	High
Lead	Medium
Nickel	Medium
Tin	Medium
Aluminum	Low

- **Contact with Mortar and Plaster**

Fresh mortar and plaster may attack zinc and zinc alloy coating when damp, but corrosion ceases when the materials dry.

- **Contact with Wood**

Metallic coated steel does not react with dry wood. Dry pressure-treated lumber is also not corrosive to zinc and no special requirements are needed to isolate steel from wood framing. Galvanized nails and screws have been successfully used in wood and steel materials for years.

- **Contact with Drywall and Insulation Products**

Drywall, mineral wool, cellulose, and rigid foam insulating products do not react with galvanized steel.

- **Contact with Concrete**

Freshly poured concrete is wet and highly alkaline, and therefore, may react with galvanized coatings. Metallic coated steel should not be embedded in concrete, unless approved for that purpose. When the concrete dries out, however, it becomes less aggressive to the galvanic coatings, provided it is protected from ground moisture. Good quality chloride-free concrete is not corrosive to zinc.

Performance of Steel in Homes

Steel framing members located in an indoor atmosphere (such as wall and floor framing) have a very low rate of corrosion. Studies have shown that the corrosion of zinc is lower than 0.1 μm per 3-year period in houses located in different rural, urban, marine, and industrial atmospheres. It can be concluded that a typical G40 zinc coated steel ($10 \mu\text{m} = 0.39$ mils) should last for more than 300 years, when protected from moisture within a building construction [7].

Recommended Corrosion Protection for Steel Floor Joists

The durability of steel framing members in residential buildings is a function of time of wetness which is related to humidity and direct exposure to moisture (i.e., rain or salt spray). Residential steel floors are generally enclosed and involve dry indoor environments. Therefore, the corrosion rate of zinc is very low.

Floor joists installed in basements and crawl spaces have the likelihood of exposure to extended periods of high humidity. A minimum metallic coating of G60 (AZ50 or GF60) should be used. Other approved coatings are acceptable.

Second story floor joists and joists installed over enclosed basements are not likely to be exposed to aggressive conditions similar to those for the outside environment. A minimum metallic coating of G40 (AZ50 or GF45) or equivalent should be adequate.

It is to be noted that a prolonged water leak (such as bathroom leaks) could cause localized corrosion in floor joists. Precautions may also be taken by installing a vapor barrier between the steel joist or track and the concrete surface.

The minimum recommended coating requirements above assume normal exposure conditions and construction practices. Steel floor members used in buildings located in harsh environments (e.g., coastal areas) may require greater corrosion protection (e.g., G90). Steel floor framing members should be located within the building envelope and adequately shielded from direct contact with moisture from the ground or the outdoor climate.

Web Holes in Steel Floor Framing Members

Most manufacturers provide joists with holes (also called punchouts, penetrations, or perforations) in the webs to accommodate electrical installation plumbing lines, and other trade installations. A punched hole is usually provided 12 inches (305 mm) from each end. Intermediate holes are typically placed at 24-inch (610 mm) intervals along the centerline of the web. Joists with unpunched webs are also available. Joist web holes are classified into two categories: (1) standard web holes, and (2) folded web holes. Screw sized holes are permitted anywhere along the joist framing member.

Steel Tip

Plumbing, electrical, and HVAC systems should be considered when deciding on web hole size and locations.

Standard Web Holes. Standard size holes can be factory or field punched. Standard hole sizes and minimum spacing requirements in webs of floor joists are shown in Figure 3.3 and Table 3.4. Holes should only be placed along the centerline of the web of the framing member and should have a minimum edge distance, measured from the edge of the hole to the edge of bearing support, of not less than 10 inches (254 mm). Holes with minimum edge (or end) distances less than 10 inches (254 mm) should be patched. Should larger holes be required for vents, drainlines, or other mechanical installations, reinforcement is required around the installed piping to protect the web from failing. Web reinforcement can be accomplished in several ways. The most common method is to weld or fasten a sheet steel plate around the hole to bring the joist strength up to its original value. As a rule of thumb, if you remove more than 50 percent of the web depth, reinforcement should be required.

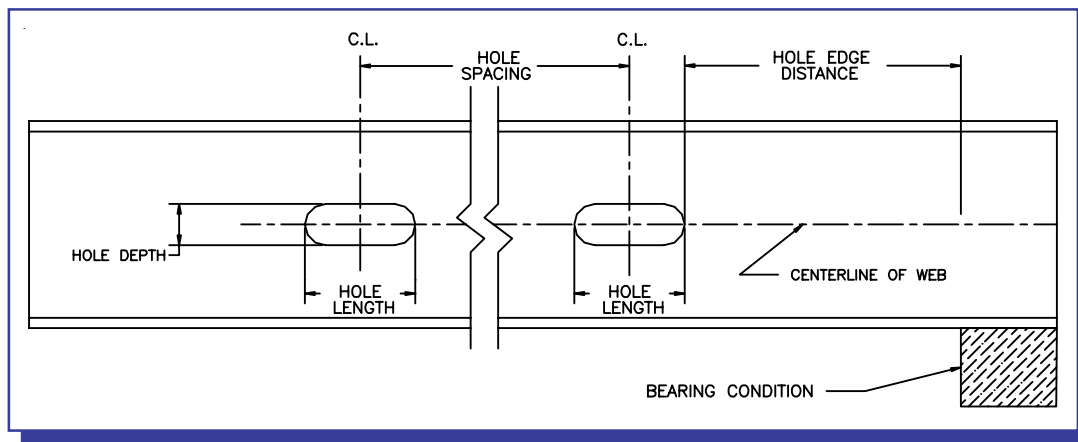

Figure 3.3. Standard Web Hole in a Floor Joist

Folded Web Holes. Folded holes are large openings in the webs of steel joists that are typically factory punched. The hole is punched in a way that the steel folds around the opening to provide a stiffening lip that retains or improves the strength of the joist at the hole location. The larger opening makes the joist lighter and provides room for ductwork and drainpipes. Dimensions for folded holes (also referred to as stiffened holes) are given in Table 3.5 and shown in Figure 3.4. Similar to standard holes, folded holes should be located only along the centerline of the web of the framing member. The TradeReady® joist (a proprietary system that uses the folded web hole technique) also has a specialty track that is used with the joist as shown in Figure 3.5. The advantages are primarily in ease of installation and labor savings. The rim joist may also be used as a header over smaller wall openings thereby economizing wall framing.

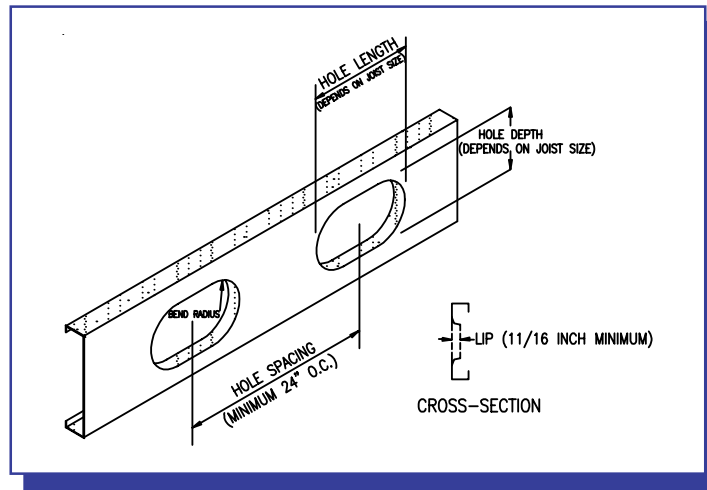

Figure 3.4. Folded Web Hole in a Floor Joist

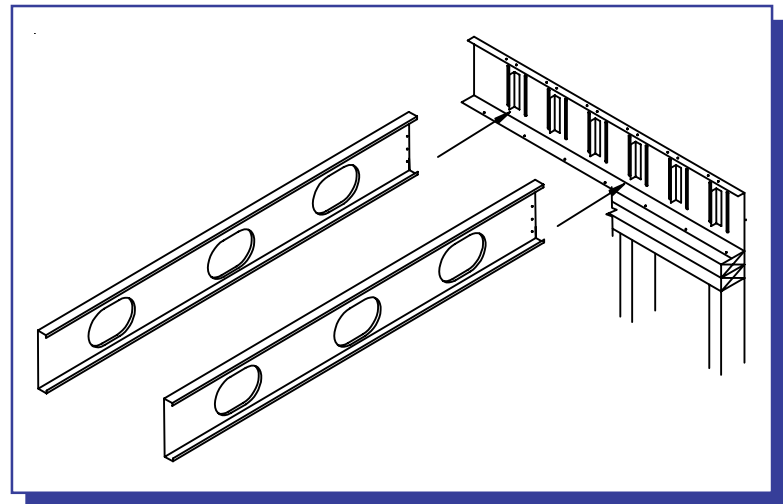

Figure 3.5. TradeReady® Joist Rim Track

Table 3.4. Standard Hole Dimensions and Spacing in Floor Joist Webs

Nominal Joist Size	SSMA Designation	Maximum Hole Depth ¹ (in.)	Maximum Hole Length ² (in.)	Minimum Hole Spacing ³ (in.)
2 x 8 x 43	800S162-43	3.25	8	24
2 x 8 x 54	800S162-54	3.25	8	24
2 x 8 x 68	800S162-68	3.25	8	24
2 x 9 x 54	925S162-54	3.75	10	24
2 x 9 x 68	925S162-68	3.75	10	24
2 x 10 x 54	1000S162-54	4	10.5	24
2 x 10 x 68	1000S162-68	4	10.5	24
2 x 12 x 54	1200S162-54	2.5	4.5	24
2 x 12 x 68	1200S162-68	4.75	12	24

For SI: 1 inch = 25.4 mm.

¹ Hole depth is the size of the hole measured across the depth of the joist.

² Hole length is the size of the hole measured along the length of the joist.

³ Hole spacing is the center-to-center distance between holes.

Table 3.5. Folded Hole Dimensions and Spacing in Floor Joist Webs

Nominal Joist Size	SSMA Designation	Maximum Hole Depth ¹ (in.)	Maximum Hole Length ² (in.)	Hole Radius (in.)	Minimum Hole Spacing ³ (in.)
2 x 8 x 43	800S162-43	4.25	7.00	2.21	24
2 x 8 x 54	800S162-54	4.25	7.00	2.21	24
2 x 8 x 68	800S162-68	4.25	7.00	2.21	24
2 x 9 x 54	925S162-54	6.25	9.00	3.21	24
2 x 9 x 68	925S162-68	6.25	9.00	3.21	24
2 x 10 x 54	1000S162-54	6.25	9.00	3.21	24
2 x 10 x 68	1000S162-68	6.25	9.00	3.21	24
2 x 12 x 54	1200S162-54	6.25	9.00	3.21	24
2 x 12 x 68	1200S162-68	6.25	9.00	3.21	24

For SI: 1 inch = 25.4 mm.

¹ Hole depth is the size of the hole measured across the depth of the joist.

² Hole length is the size of the hole measured along the length of the joist.

³ Hole spacing is the center-to-center distance between holes.

Cutting, Notching, and Hole Patching of Steel Floor Framing Members

Flanges and lips add tremendous strength to a cold-formed steel member. Cutting or notching the flanges or lips will reduce the strength and weaken the member. Therefore, flanges and lips of joist members must not be cut or notched without an approved design. Holes, cuts, or notches in joist webs violating the requirements of the Web Holes Section must be patched with a solid steel plate, joist, or track section in accordance with Figure 3.6. The steel patch thickness should be equivalent to or greater than the thickness of the receiving member and should extend a minimum of one-inch (25 mm) beyond all edges of the hole. The steel patch should be fastened to the web of the receiving member with #8 screws (minimum) spaced no greater than 2 inches (51 mm) center-to-center along the edges of the patch with minimum edge distance of 1/2 inch (13 mm). Folded web holes located at the edge of the joist member should be stiffened as shown in Figure 3.7.

Steel Tip

Never cut or punch the flanges of a joist. Cut or punch the web only.

Floor joist framing members should be replaced when:

- the depth of the standard hole, measured across the web, exceeds 75 percent of the depth of the web; or,
- the length of the standard hole, measured along the web, exceeds 12 inches (305 mm) or the depth of the web, whichever is greater; or,
- the length of the folded hole, measured along the web, exceeds 12 inches (305 mm) or the depth of the web, whichever is greater; or,
- the depth of the folded hole, measured across the web, exceeds 70 percent of the depth of the web.
- the member is damaged or dented such that the shape does not comply with the requirements of Table 3.1 at any point on the member.

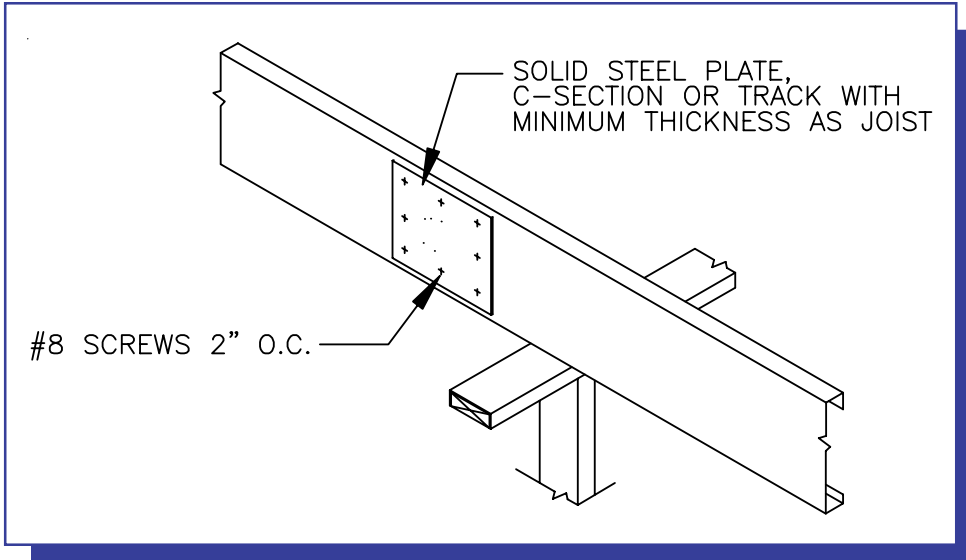

Figure 3.6. Standard Web Hole Patch

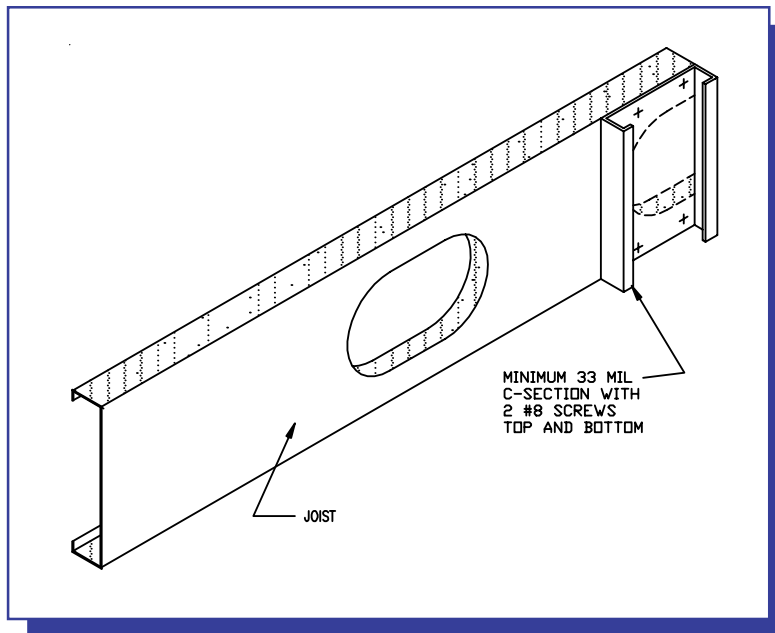

Figure 3.7. Folded Web Hole Patch

Web Stiffeners for Steel Floor Framing Members

Web stiffeners (also called bearing stiffeners or transverse stiffeners) are used to strengthen the web of the joist member by increasing its web crippling strength and preventing the joist from crumpling due to applied loads. Web stiffeners are typically installed at joist bearing and concentrated load locations.

Web stiffeners are fabricated as follows:

- Stiffeners are fabricated from a minimum of 33 mil (0.84 mm) C-shaped members or 43 mil (1.1 mm) track sections.
- Each stiffener is fastened to the web of the member it is stiffening with minimum #8 screws equally spaced as shown in Figures 3.8 and 3.9 (The TradeReady® rim joist includes a “built-in” web stiffener which simplifies installation).
- Stiffeners must extend across the depth of the stiffened member’s web.
- Stiffeners can be installed on either side of the joist member (either inside or outside of the joist web). Generally, installing the stiffener on the outside is simpler.

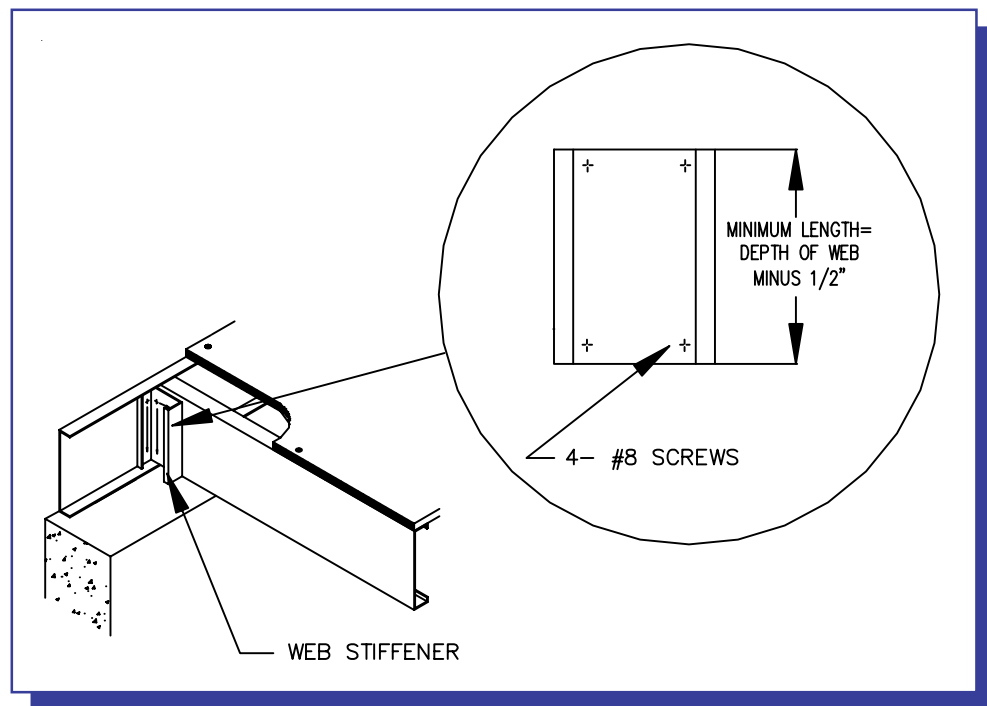

Figure 3.8. Web Stiffener Detail

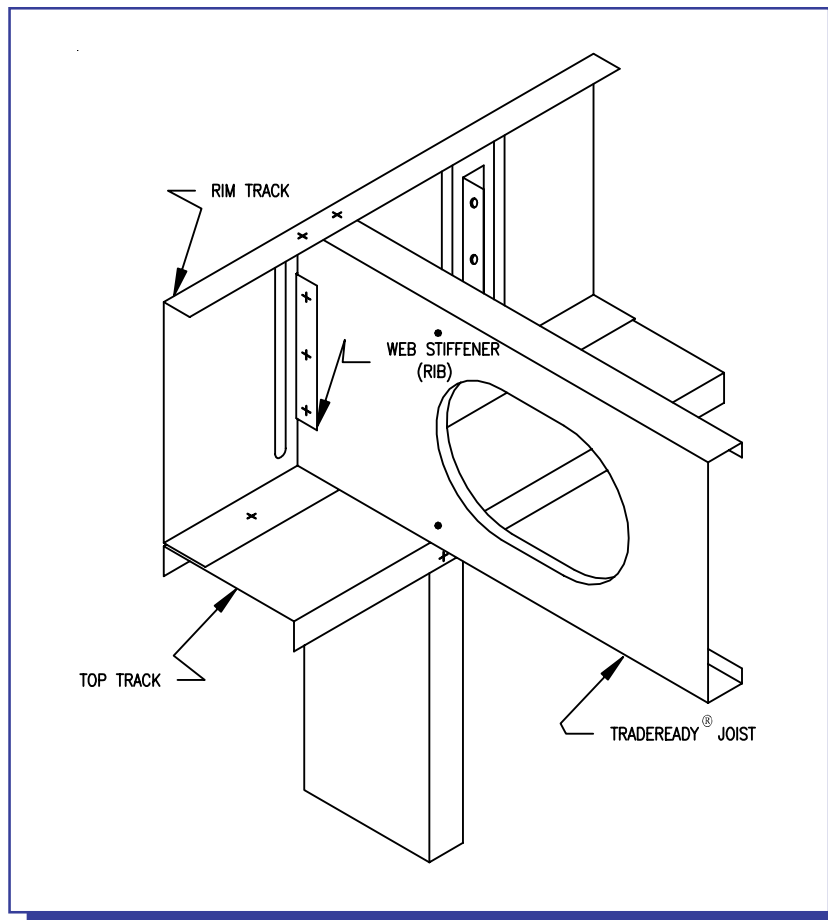

Figure 3.9. TradeReady® Joist Web Stiffener

Clip Angles

Clip angles are typically used for anchoring floor joists to foundations. Clip angles should be a minimum of 2 inches x 2 inches by 33 mils (51 mm x 51 mm x 0.84 mm), unless otherwise noted. All clip angle materials must comply with the applicable provisions of this chapter.

References

- [1] ASTM A653/A653M-1996, *Standard Specification for Steel Sheet, Zinc-Coated (Galvanized) or Zinc-Iron Alloy-Coated (Galvannealed) by the Hot-Dip Process*, American Society for Testing and Materials (ASTM), West Conshohocken, PA. 1996.
- [2] ASTM A792/A792M, *Standard Specification for Steel Sheet, 55% Aluminum-Zinc Alloy-Coated by the Hot-Dip Process*, American Society for Testing and Materials (ASTM), West Conshohocken, PA. 1996.
- [3] ASTM A875/A875M, *Standard Specification for Steel Sheet, Zinc-5% Aluminum Alloy Metallic-Coated by the Hot-Dip Process*, American Society for Testing and Materials (ASTM), West Conshohocken, PA. 1996.
- [4] ASTM C955-96a, *Standard Specification for Load-Bearing (Transverse and Axial) Steel Studs, Runners (Tracks), and Bracing or Bridging for Screw Application of Gypsum Board and Metal Plaster Bases*, American Society for Testing and Materials (ASTM), West Conshohocken, PA. 1996.
- [5] ASTM C645-96a, *Standard Specification for Nonstructural Steel Framing Members*, American Society for Testing and Materials (ASTM), West Conshohocken, PA. 1996.
- [6] ASTM A370-97a, *Standard Test Methods and Definitions for Mechanical Testing of Steel Products*, American Society for Testing and Materials (ASTM), West Conshohocken, PA. 1997.
- [7] *Durability of Cold-Formed Steel Framing Members*, Publication No. RG-9605, American Iron and Steel Institute (AISI), Washington, DC, October, 1966.

Floor Construction

Introduction

Steel floor construction typically follows the conventional construction method. The construction requirements in this chapter are based primarily on the following documents:

- Prescriptive Method for Residential Cold-Formed Steel Framing, (Prescriptive Method) [1].
- Innovative Residential Floor Construction: Structural Evaluation of Steel Joists with Pre-Formed Web Openings [2].
- Innovative Residential Floor Construction: Horizontal Diaphragm Values for Cold-Formed Steel Framing [3].
- Specification for the Design of Cold-Formed Steel Structural Members [4].
- Student Manual – Residential Steel Framing, National Training Curriculum [5].

The prescriptive construction requirements in this chapter are intended to represent sound engineering and construction practice. They are intended to be compatible with building code requirements and conventional construction practice. The document is not intended to restrict the use of alternative methods that may result in equivalent or improved designs and economy.

Applicability Limits

The provisions in this document apply to the construction of cold-formed steel floors for detached one- or two-family dwellings, townhouses, and other attached single-family dwellings. Floor construction in accordance with this document should be limited by the applicability limits set forth in Table 4.1. The limitations are intended to define an appropriate use of this document for a majority of one- and two-family dwellings.

Steel Tip

Requirements in this chapter apply to in-line framing when floor joists are bearing on a steel wall with a non-load bearing top track or a wood wall with a single 2x top plate. In-line framing is not required for wood walls with double 2x top plate.

Table 4.1. Applicability Limits

Attribute	Limitation
Design wind speed ¹	90 mph (145 km/hr) Exposure C or 100 mph (160 km/hr) Exposure B, maximum fastest-mile wind speed
Seismic Zone	Zone 4 maximum
Floor dead load	10 psf (0.48 kN/m ²) maximum
Floor live load First floor Second floor (sleeping areas)	40 psf (1.92 kN/m ²) maximum 30 psf (1.44 kN/m ²) maximum
Floor joist spacing	24 inches (610 mm) maximum
Floor Cantilevers	24 inches (610 mm) maximum

For SI: 1 inch = 25.4 mm, 1 psf = 0.0479 kN/m², 1 mph = 1.61 km/hr, 1 foot = 0.3 m.

¹ Wind speeds in this document are based on fastest-mile wind speeds. When using design wind speed maps based on 3-second gust wind speeds, the fastest-mile speeds in this document shall be multiplied by a conversion factor of 1.2 to obtain approximate 3-second gust wind speeds. In wind zones greater than 90 mph, additional connectors may be required to fasten walls, floors, and the foundation together.

Foundation Preparation

The foundation provides a stable base for the house. It is essential that the foundation is structurally sound and level. Steel floor joists can be used with concrete, steel, wood, or masonry foundations. Foundation dimensions are very important to the steel framing contractor, because the joists are typically ordered cut to length. A slight change in the foundation dimensions would throw everything off and cause wasted time in re-cutting of the members. The steel framing contractor should ensure that the foundation is square and level and that the anchor bolts are properly spaced. To the extent possible, steel framing is most advantageous when on site cutting and fitting is minimized.

It is critical that all corners of the foundations be as true as possible. When checking for squareness, it is good practice to verify the diagonal measurement of every major offset in the foundation. Leveling the foundation can be accomplished with a surveyor's transit. Shimming or grouting is an acceptable method of leveling the foundation. Many contractors use a wood sill to accommodate any irregularities in the foundation that may impact the ability to ensure that all joists are bearing in contact with the foundation wall.

Basic Floor Framing Connections

Cold-formed steel floor framing can be anchored directly to the foundation (concrete, masonry, wood, steel) or anchored to a wood sill on top of the foundation. Either way, steel floor joists should be at least nominally anchored to the foundation to prevent movements from wind or earthquakes. The pressure created by hurricane force and tornado winds or earthquake ground shaking (lateral loads) can cause shifting, overturning (uplifting of home), and rotation (pivoting on the foundation).

Steel Tip

Apply building paper or caulking to separate steel from concrete.

Construction details, anchoring, and fastening requirements (size and spacing) are provided in Figures 4.1 through 4.5 and Tables 4.2 and 4.3 (such as joist to foundation, joist to wood sill, joist to load bearing wall, and joist to wood top plate connection detail). Additional construction details are provided in Figures 4.6 through 4.11 to address various options and conditions (such as floor to concrete masonry, joist to steel beam, joist to steel wall, floor to crawl space, and joist to interior steel stud connection detail).

Table 4.2. Basic Fastening Schedule

Description of Building Elements	Number and Size of Fasteners ¹	Spacing of Fasteners
Floor joist to an interior load bearing wall	2 - #8 screws	Each joist
Floor joist to track at end of joist	2 - #8 screws	One per flange or two per bearing stiffener
Subfloor sheathing to floor joists	#8 screws ²	6 inches on center on edges and 12 inches on center at intermediate supports

For SI: 1 inch = 25.4 mm.

¹ All screw sizes shown are minimum.

² Head styles should be bugle-head, flat head, or similar with a minimum head diameter of 0.29 inch (7-mm).

Table 4.3. Floor to Foundation or Bearing Wall Connection Requirements

Framing Condition	Wind Speed (mph), Exposure, and Seismic Zones ^{1,2,3,4}	
	Up to 90 A/B or 70 C or Seismic Zones 0, 1, 2, & 3	Up to 100 A/B or 90 C or Seismic Zone 4
Floor joist track or end joist to foundation per Figure 4.1 ⁵	1/2" minimum diameter anchor bolt and clip angle spaced at 6' o.c. with 8-#8 screws	1/2" minimum diameter anchor bolt and clip angle spaced at 4' o.c. with 8-#8 screws
Floor joist track or end joist to wood sill per Figure 4.2 ⁵ Per Figures 4.4 or 4.5	Steel plate spaced at 4' o.c. with 4-#8 screws and 4-10d or 6-8d common nails <i>or</i> Metal connector spaced at 4' o.c. with 2-10d common nails to 2x wood plate and 3-#8 screws to joist <i>or</i> One #8 screw spaced at 12" o.c. through rim track	Steel plate spaced at 2' o.c. with 4-#8 screws and 4-10d or 6-8d common nails <i>or</i> Metal connector at each joist with 2-10d common nails to 2x wood plate and 3-#8 screws to joist <i>or</i> One #8 screw spaced at 8" o.c. through rim track flange
Floor joist to wall track of exterior steel load bearing wall per Figure 4.3	2-#8 screws	3-#8 screws
Joist track or end joist to bearing wall top track or wood top plate per Figure 4.3	1-#8 screw at 24" o.c.	1-#8 screw at 24" o.c.

For SI: 1 inch = 25.4 mm, 1 mph = 1.61 km/hr, 1 foot = 0.3m.

- ¹ Use the highest of the wind speed and exposure or the seismic requirements for a given site.
- ² All screw sizes shown are minimum.
- ³ Anchor bolts shall be located not more than 12 inches (305 mm) from corners or the termination of bottom tracks (e.g. at door openings or corners).
- ⁴ Screws should be long enough to penetrate through joist flange. Pilot point screws are recommended. Nail pins may be used, consult manufacturer.
- ⁵ Requirements also apply to cantilevered floor joists.

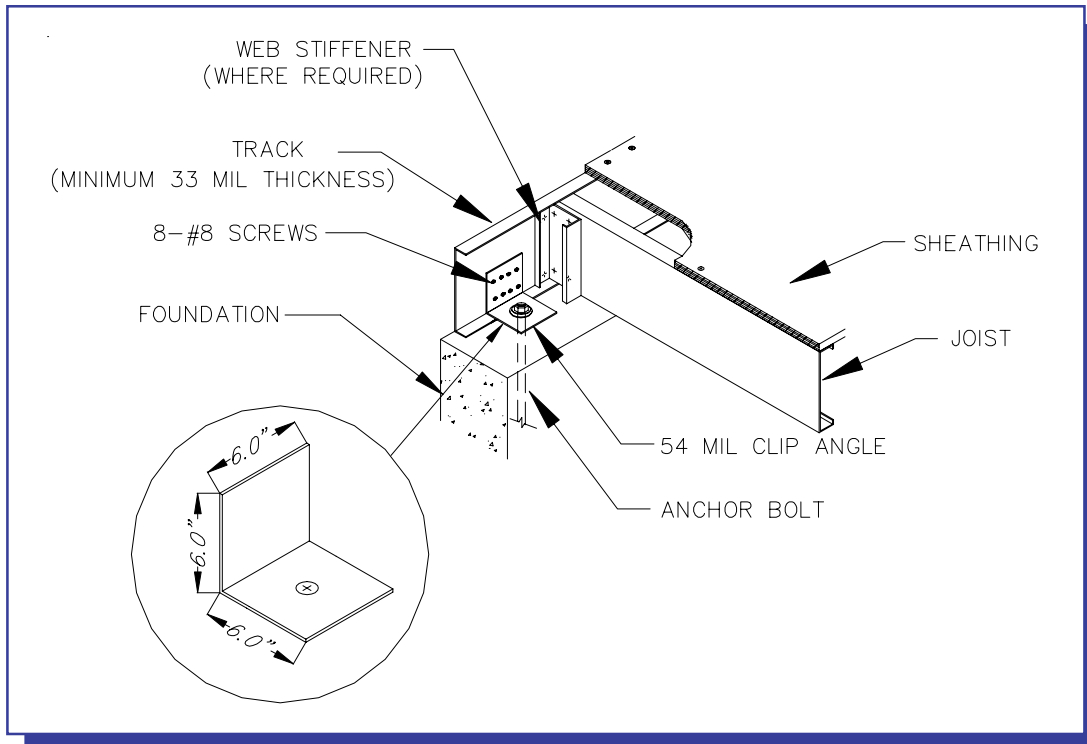

Figure 4.1. Steel Floor to Foundation Connection Detail

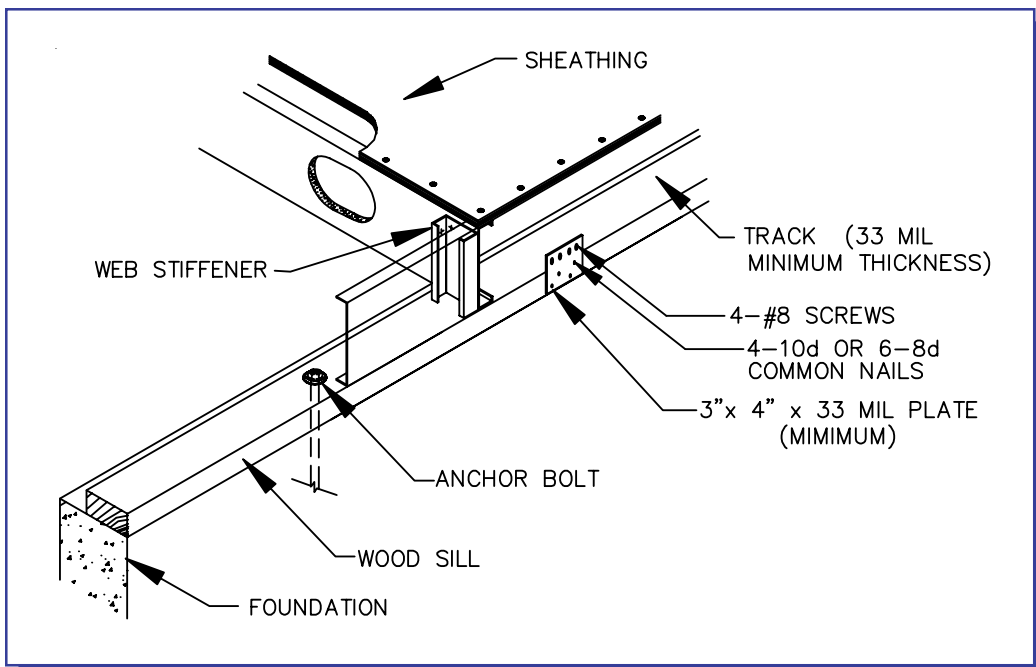

Figure 4.2. Steel Floor to Wood Sill Connection Detail

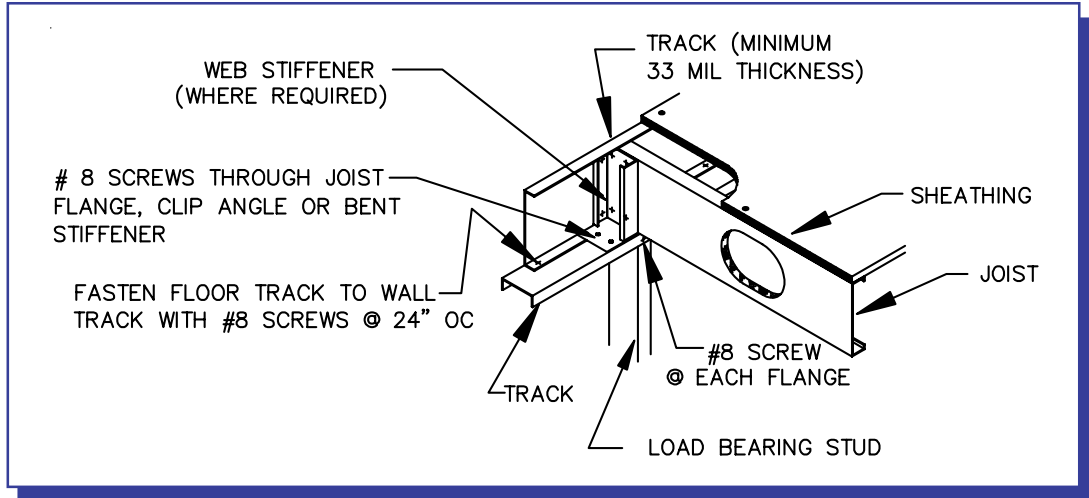

Figure 4.3. Steel Floor to Load Bearing Wall Connection Detail

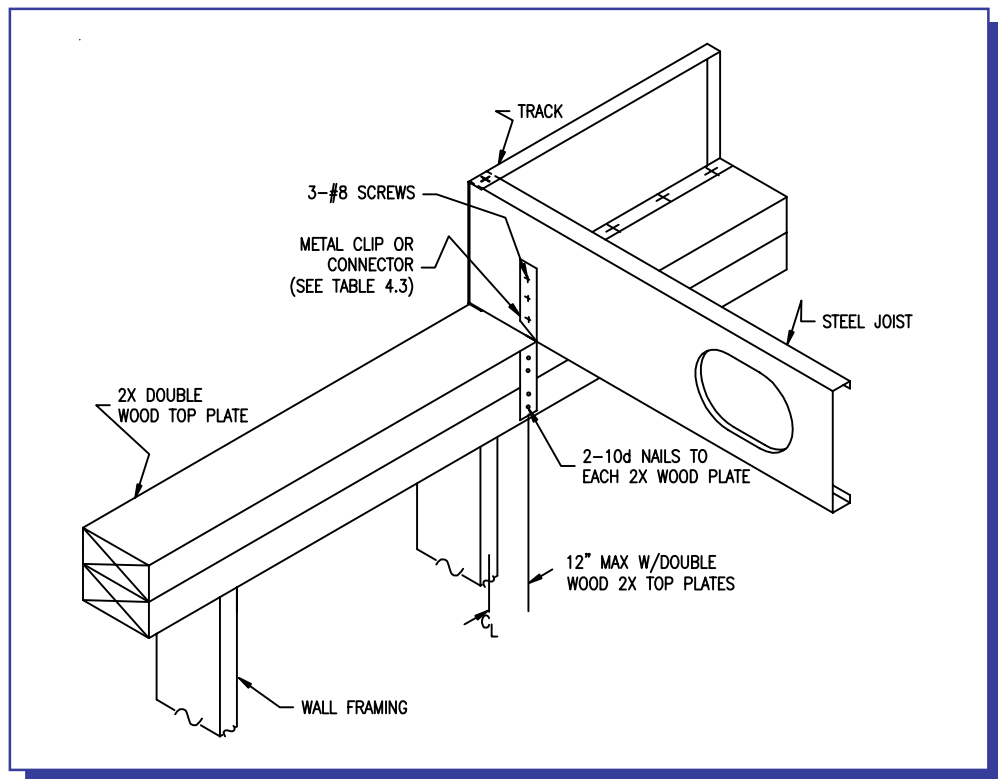

Figure 4.4. Steel Floor to Double 2x Wood-Top-Plate Connection Detail

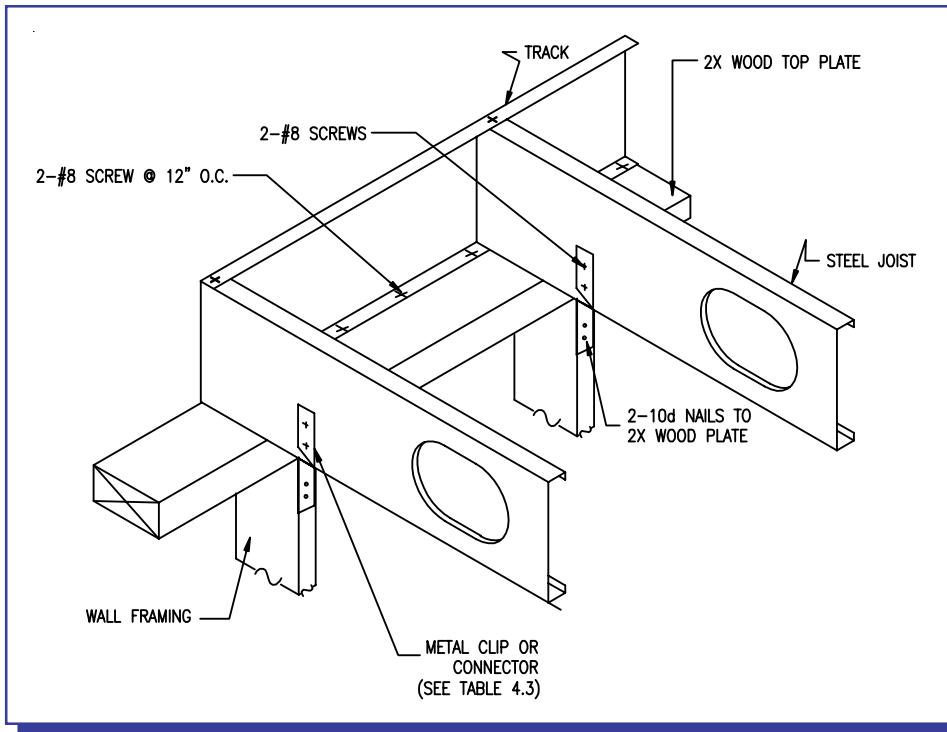

Figure 4.5. Steel Floor to Single 2x Wood-Top-Plate Connection Detail

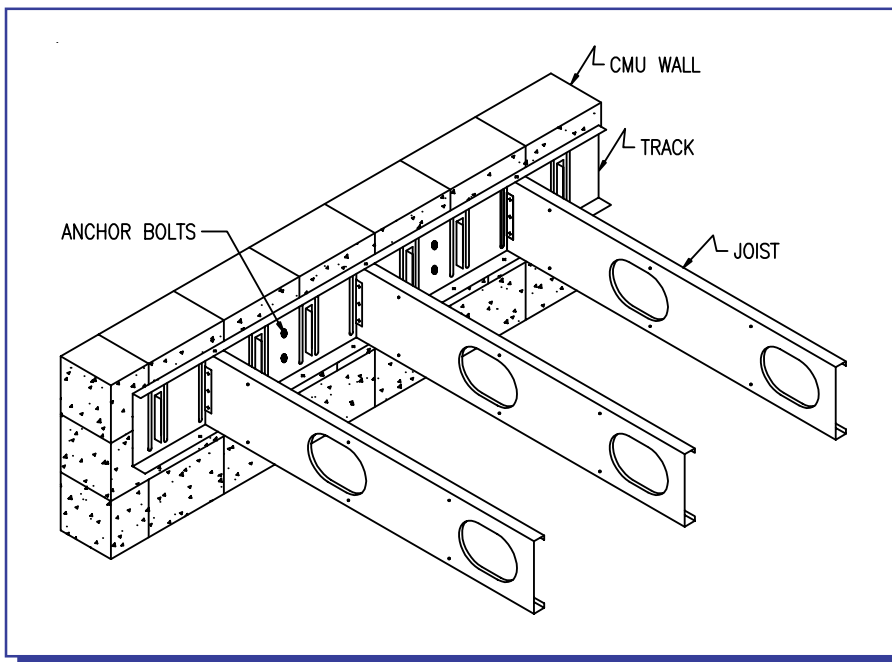

Figure 4.6. TradeReady® Floor System to Concrete Masonry Unit Connection Detail

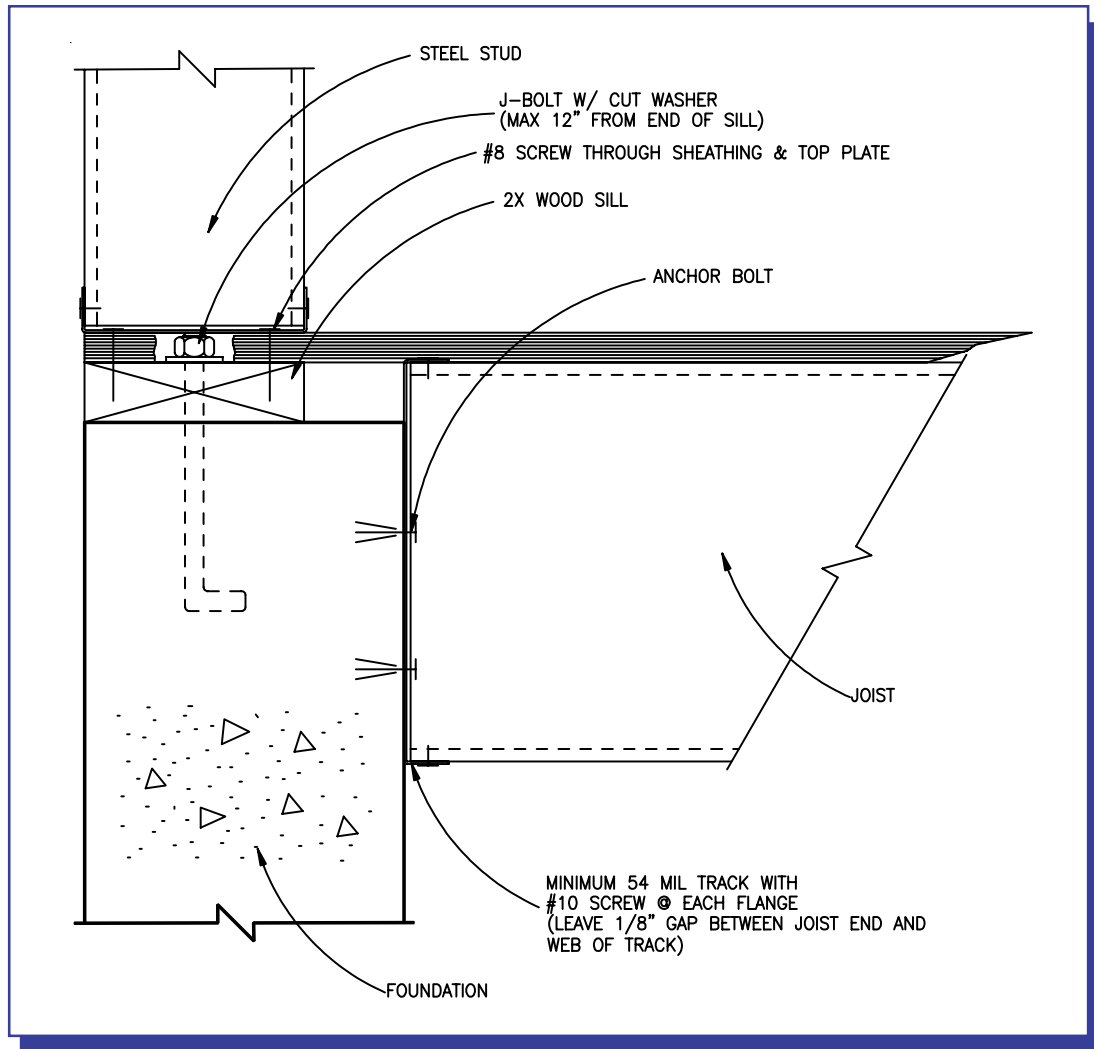

Figure 4.7. Steel Floor to Foundation - Sidewall Connection Detail

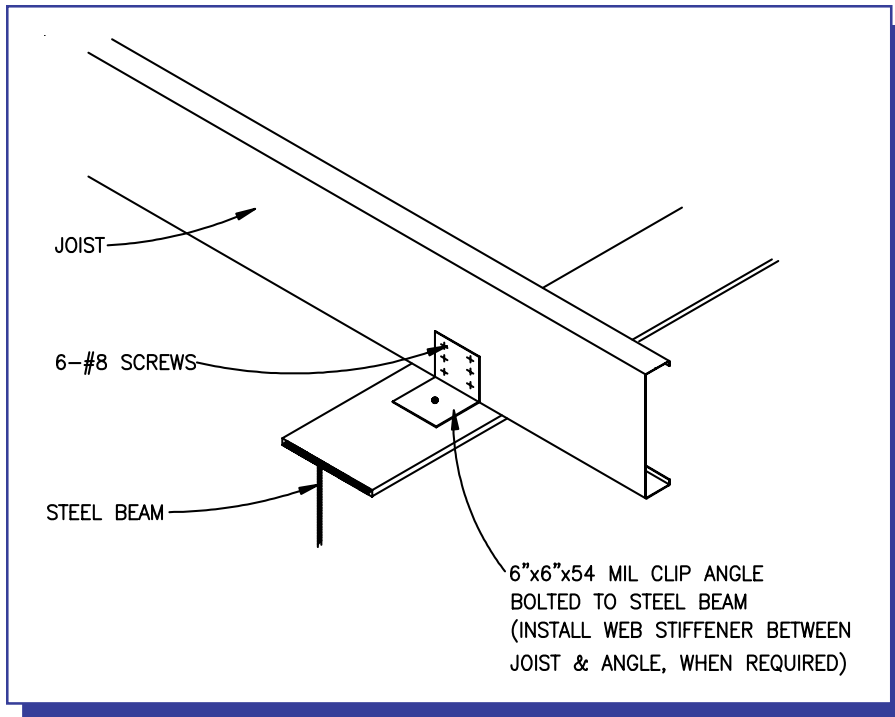

Figure 4.8. Joist-to-Steel Beam Connection Detail

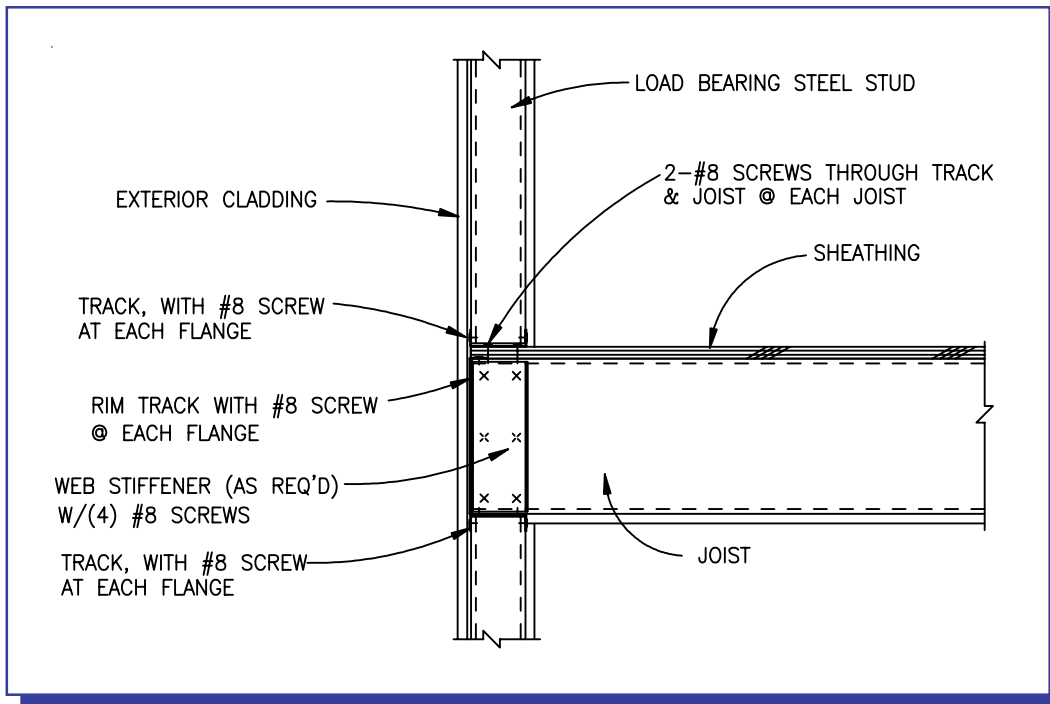

Figure 4.9. Joist-to-Steel Wall Connection Detail

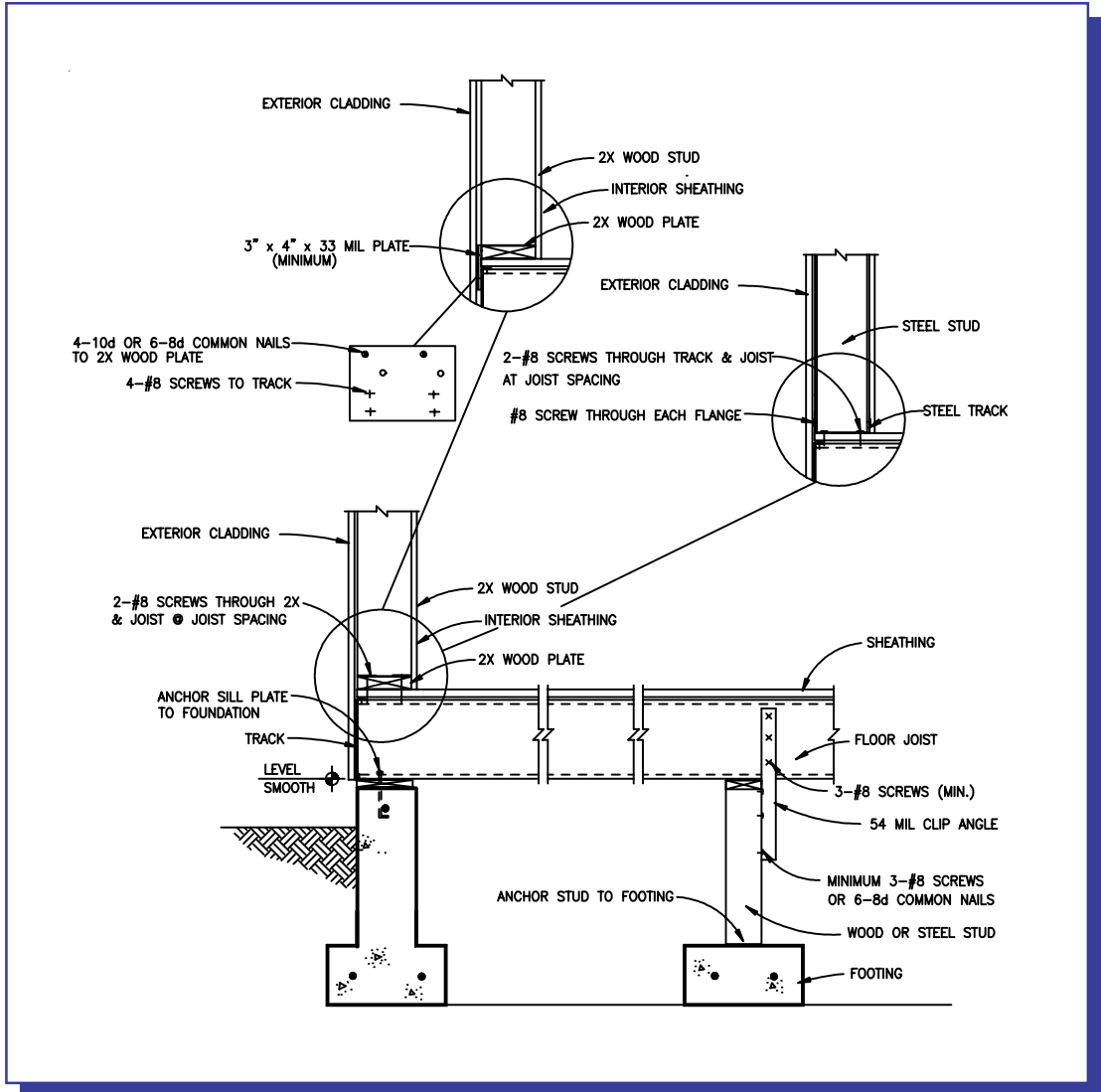

Figure 4.10. Steel Floor to Crawl Space Connection Detail

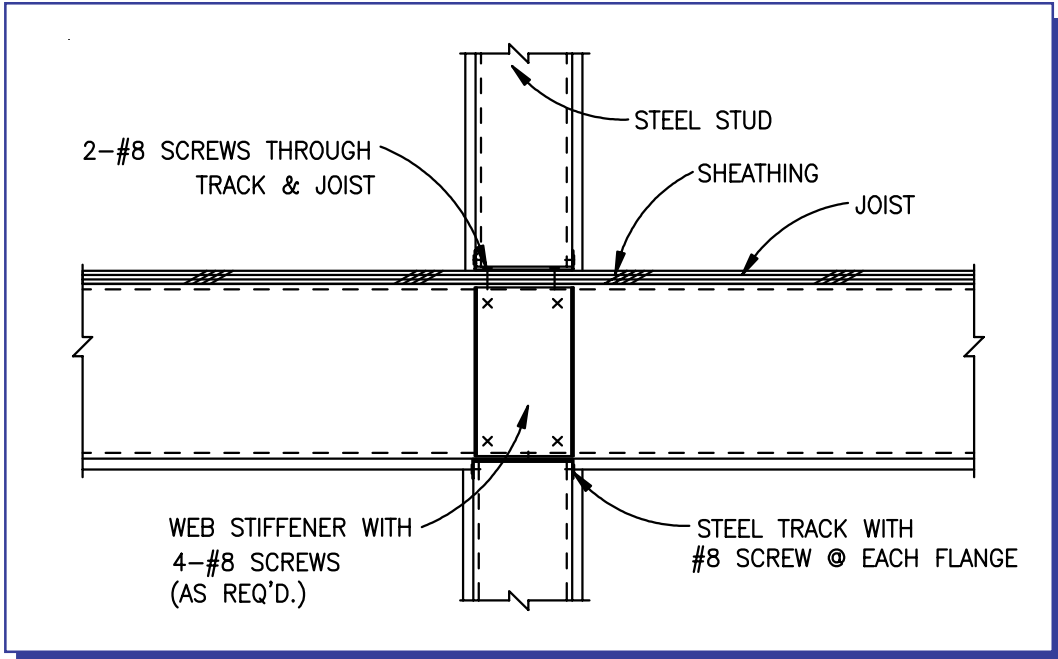

Figure 4.11. Steel Joist-to-Interior Load-Bearing Steel Stud Connection Detail

Floor Joist Span

Single span CFS joists span between two supports, as shown in Figure 4.12, while multiple span CFS joists span continuously over one or more intermediate supports as shown in Figure 4.13. An intermediate support can be a wood-bearing wall, steel or wood beam, concrete wall, or any other load-bearing support. It is essential to distinguish between single and multiple spans because there are different tables (see Tables 4.4 and 4.5) for each condition. The maximum unsupported span in these tables can differ significantly for a particular application.

Steel Tip

Consider both the single span and multiple span joist tables before selecting the joist size and thickness.

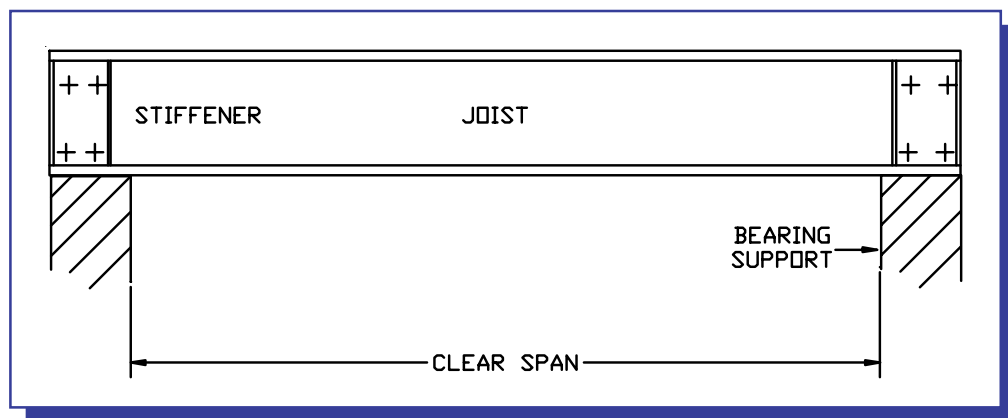

Figure 4.12. Single Span Joist

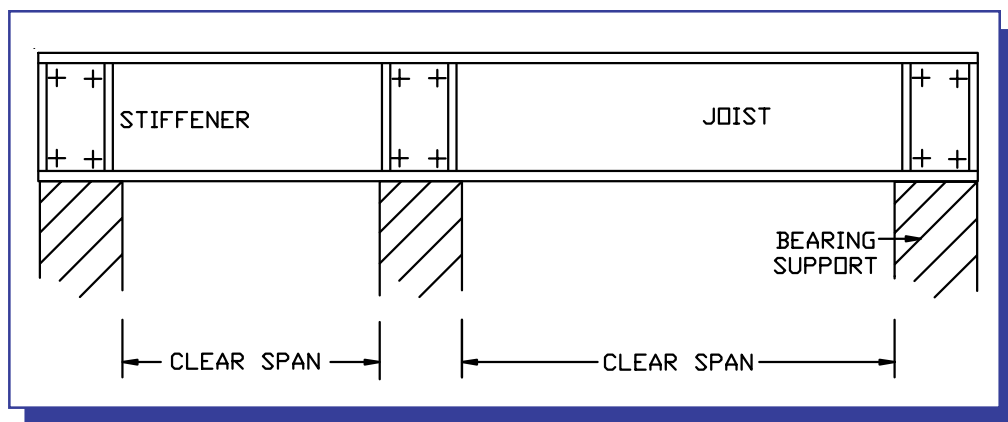

Figure 4.13. Multiple Span Joist

Selecting Steel Joist Size and Span

A clear joist span is measured from the inside of one bearing wall to the inside of the other bearing wall. The joist size is selected based on floor loading, joist spacing, clear span requirement, and the number of spans (i.e., single or multiple). Maximum CFS joist spans are tabulated in Table 4.4 for single spans and Table 4.5 for multiple spans. When continuous joist members are used for multiple spans, the interior bearing supports must be located within two feet (0.6 m) of the steel joist's mid-span as shown in Figure 4.14. In addition, each of the individual spans must not exceed the applicable spans in the table. Floor joists must have a bearing support length of not less than 1.5 inches (38 mm) for exterior wall supports and 3.5 inches (89 mm) for interior wall supports. Joist tracks must have a minimum thickness of 33 mils (0.84 mm). When used as part of a floor header or trimmer, the track must be at least the same thickness of the joist used in the built-up header member. Web stiffeners, where required, are fabricated and installed in accordance with this chapter and Chapter 3.

Steel Tip

Joists must have a minimum of 1.5-inch and 3.5-inch bearing support length for exterior and interior walls respectively.

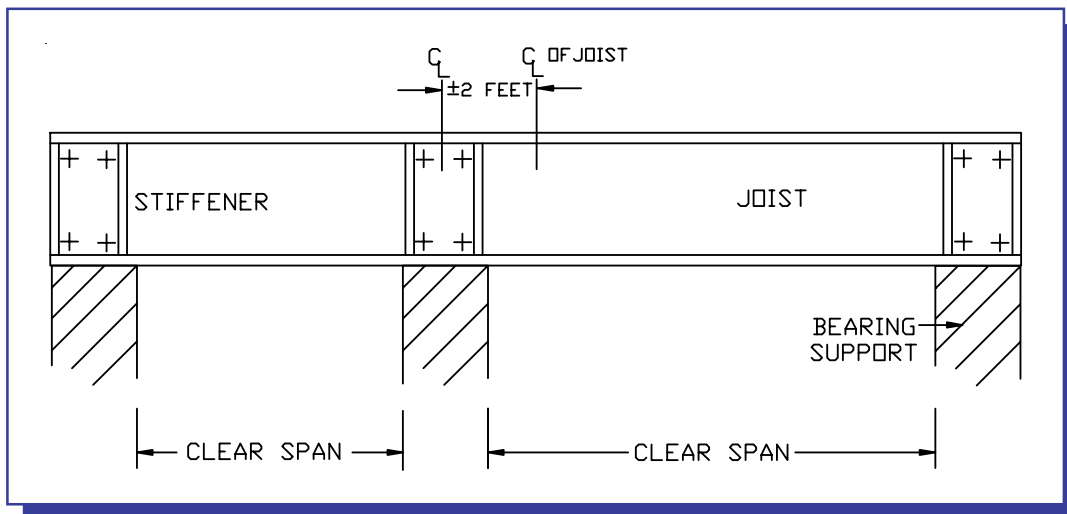

Figure 4.14. Location of Intermediate Supports

Floor loading requirements can be found in the local building code. A 30 psf live load is usually required for bedroom areas and a 40 psf live load is used for all other areas. The determination of the required span is usually based on the building plan, the need for open space, and the design loads. The choice between a single and a multiple span is based on economics, availability, and ease of installation and is typically determined early in the design stage. The single span table can be used over intermediate supports provided that each joist runs from one support to the other and are only nominally spliced to each other to allow some movement at the splice. Multiple span tables can be used when a continuous joist or tied (i.e., overlapped) joists span over intermediate supports.

Table 4.4. Allowable Spans For Cold-Formed Steel Floor Joists - Single Spans^{1,2,3,4}

Single Spans with Web Stiffeners ⁵									
Nominal Joist Size	Member Designation	Sleeping Rooms (30 psf Live Load)				Dwelling Units (Except Sleeping Rooms) (40 psf Live Load)			
		Spacing (inches)				Spacing (inches)			
		12	16	19.2	24	12	16	19.2	24
2 x 8 x 43	800S162-43	17'-1"	15'-6"	14'-7"	13'-7"	15'-6"	14'-1"	13'-3"	12'-3"
2 x 8 x 54	800S162-54	18'-4"	16'-8"	15'-9"	14'-7"	16'-8"	15'-2"	14'-3"	13'-3"
2 x 8 x 68	800S162-68	19'-8"	17'-11"	16'-10"	15'-7"	17'-11"	16'-3"	15'-4"	14'-2"
2 x 9 x 54	925S162-54	20'-8"	18'-9"	17'-8"	16'-5"	18'-9"	17'-1"	16'-0"	14'-11"
2 x 9 x 68	925S162-68	21'-11"	19'-11"	18'-9"	17'-5"	19'-11"	18'-1"	17'-0"	15'-10"
2 x 10 x 54	1000S162-54	22'-1"	20'-1"	18'-10"	17'-6"	20'-0"	18'-3"	17'-2"	15'-11"
2 x 10 x 68	1000S162-68	23'-8"	21'-6"	20'-3"	18'-10"	21'-6"	19'-7"	18'-5"	17'-1"
2 x 12 x 54	1200S162-54	25'-9"	23'-4"	21'-10"	19'-7"	23'-4"	21'-3"	19'-7"	17'-6"
2 x 12 x 68	1200S162-68	27'-8"	25'-1"	23'-8"	21'-11"	25'-1"	22'-10"	21'-6"	19'-11"
Single Spans without Web Stiffeners ⁵									
2 x 8 x 43	800S162-43	13'-10"	10'-5"	8'-8"	6'-11"	11'-1"	8'-4"	6'-11"	5'-6"
2 x 8 x 54	800S162-54	18'-4"	16'-8"	14'-8"	11'-8"	16'-8"	14'-8"	12'-2"	9'-9"
2 x 8 x 68	800S162-68	19'-8"	17'-11"	16'-10"	15'-7"	17'-11"	16'-3"	15'-4"	14'-2"
2 x 9 x 54	925S162-54	17'-0"	13'-7"	11'-8"	9'-9"	16'-10"	12'-7"	10'-6"	8'-0"
2 x 9 x 68	925S162-68	21'-11"	19'-11"	18'-9"	17'-5"	19'-4"	15'-7"	17'-0"	11'-5"
2 x 10 x 54	1000S162-54	21'-5"	16'-1"	13'-4"	10'-8"	17'-1"	12'-10"	10'-8"	8'-6"
2 x 10 x 68	1000S162-68	23'-9"	21'-6"	20'-3"	18'-4"	21'-6"	19'-7"	18'-5"	14'-8"
2 x 12 x 54	1200S162-54	N/A	N/A	N/A	N/A	N/A	N/A	N/A	N/A
2 x 12 x 68	1200S162-68	27'-8"	25'-1"	21'-4"	17'-1"	25'-1"	20'-6"	17'-1"	13'-8"

For SI: 1 inch = 25.4 mm, 1 psf = 0.0479 kN/m², 1 foot = 0.3m.

¹ Table provides the maximum clear span in feet and inches.

² Deflection criteria: L/480 for live loads; L/240 for total loads.

³ Floor dead load = 10 psf (0.479 kN/m²)

⁴ Refer to Table 3.1 for actual joist size.

⁵ N/A indicates joist should not be installed without a stiffener.

Table 4.5. Allowable Spans For Cold-Formed Steel Floor Joists - Multiple Spans^{1,2,3,4,5,6}

Multiple Spans with Web Stiffeners ⁷									
Nominal Joist Size	Member Designation	Sleeping Rooms (30 psf Live Load)				Dwelling Units (Except Sleeping Rooms) (40 psf Live Load)			
		Spacing (inches)				Spacing (inches)			
		12	16	19.2	24	12	16	19.2	24
2 x 8 x 43	800S162-43	19'-5" (a)	16'-10" (a)	15'-4" (a)	13'-9" (a)	17'-5" (a)	15'-1" (a)	13'-9" (a)	11'-11" (a)
2 x 8 x 54	800S162-54	23'-0" (i)	19'-11" (i)	18'-2" (i)	16'-3" (i)	20'-7" (i)	17'-10" (i)	16'-3" (i)	14'-6" (n)
2 x 8 x 68	800S162-68	25'-11" (i)	22'-5" (i)	20'-5" (i)	18'-3" (i)	23'-2" (i)	20'-0" (i)	18'-3" (i)	16'-4" (i)
2 x 9 x 54	925S162-54	25'-6" (i)	22'-1" (a)	20'-2" (a)	18'-0" (a)	22'-10" (a)	19'-9" (a)	18'-0" (a)	16'-2" (a)
2 x 9 x 68	925S162-68	28'-5" (i)	24'-7" (i)	22'-5" (i)	20'-1" (i)	25'-5" (i)	22'-0" (i)	20'-1" (i)	17'-11" (i)
2 x 10 x 54	1000S162-54	25'-6" (i)	22'-1" (a)	20'-2" (a)	18'-0" (a)	22'-9" (i)	19'-9" (a)	18'-0" (a)	16'-1" (a)
2 x 10 x 68	1000S162-68	30'-7" (i)	26'-5" (i)	24'-2" (i)	21'-7" (i)	27'-4" (i)	23'-8" (i)	18'-5" (i)	19'-4" (i)
2 x 12 x 54	1200S162-54	27'-8" (a)	23'-11" (a)	21'-10" (a)	19'-2" (a)	24'-9" (a)	21'-5" (a)	19'-2" (a)	16'-5" (a)
2 x 12 x 68	1200S162-68	32'-7" (i)	28'-3" (i)	25'-9" (i)	23'-1" (a)	29'-2" (i)	25'-3" (i)	23'-1" (a)	20'-7" (a)
Multiple Spans without Web Stiffeners ⁸									
2 x 8 x 43	800S162-43	12'-4"	9'-10"	8'-5"	7'-0"	10'-4"	8'-2"	7'-0"	5'-9"
2 x 8 x 54	800S162-54	16'-9"	13'-6"	11'-8"	9'-10"	14'-2"	11'-4"	9'-10"	8'-2"
2 x 8 x 68	800S162-68	21'-7"	17'-8"	15'-6"	13'-2"	18'-6"	15'-1"	13'-2"	11'-2"
2 x 8 x 97	800S162-97	29'-6"	25'-5"	22'-7"	19'-7"	26'-5"	22'-0"	19'-7"	16'-10"
2 x 9 x 54	925S162-54	17'-0"	13'-7"	11'-8"	9'-9"	14'-3"	11'-4"	9'-9"	8'-0"
2 x 9 x 68	925S162-68	22'-10"	18'-7"	16'-3"	13'-8"	19'-5"	15'-9"	13'-8"	11'-6"
2 x 10 x 54	1000S162-54	16'-11"	13'-6"	11'-8"	9'-8"	14'-3"	11'-3"	9'-8"	8'-0"
2 x 10 x 68	1000S162-68	23'-5"	19'-0"	16'-6"	13'-11"	19'-11"	16'-0"	13'-11"	11'-8"
2 x 12 x 54	1200S162-54	N/A	N/A	N/A	N/A	N/A	N/A	N/A	N/A
2 x 12 x 68	1200S162-68	23'-9"	19'-1"	16'-7"	13'-11"	20'-1"	16'-1"	13'-11"	11'-7"

For SI: 1 inch = 25.4 mm, 1 psf = 0.0479 kN/m², 1 foot = 0.3m.

- ¹ Table provides the maximum clear span in feet and inches to either side of the interior support.
- ² Interior bearing supports for multiple span joists shall consist of structural (bearing) walls or beams.
- ³ Deflection criteria: L/480 for live loads; L/240 for total loads.
- ⁴ Floor dead load = 10 psf (0.479 kN/m²)
- ⁵ Interior supports shall be located within two feet (610 mm) of mid span provided that each of the resulting spans does not exceed the appropriate maximum span shown in the table above.
- ⁶ Refer to Table 3.1 for actual joist size.
- ⁷ Bearing stiffeners must be installed at all support points and concentrated loads unless noted otherwise. (a) indicates web stiffeners are required at all bearing locations; (i) indicates web stiffeners are required at interior supports only; (n) indicates no web stiffeners are required due to floor load.
- ⁸ N/A indicates joist should not be installed without a stiffener.

Continuous and Lapped Steel Floor Joists

Floor joists can be installed continuously over intermediate supports or overlapped over interior supports as shown in Figures 4.15 and 4.16.

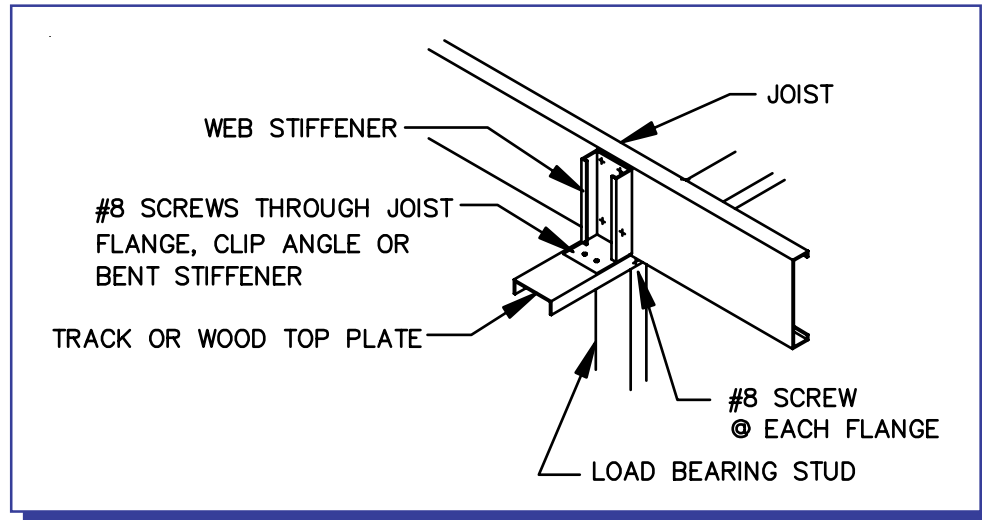

Figure 4.15. Continuous Joist Span Supported on Interior Load Bearing Wall Detail

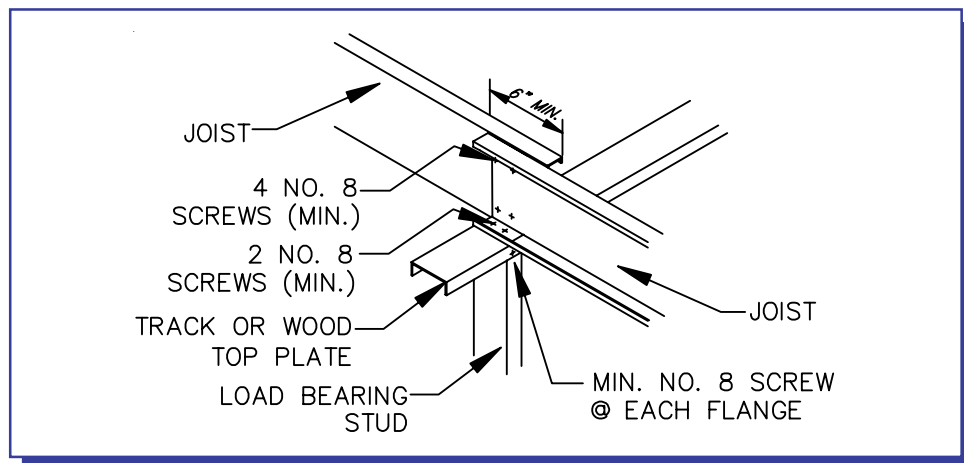

Figure 4.16. Lapped Joist Supported on Interior Load Bearing Wall Detail

Bracing of Steel Floor Joists

CFS floor joists are likely to twist, roll over, sway from one side to another, bounce, or vibrate during construction and under normal loading conditions if not properly braced. Floor bracing is also used to distribute the floor loads to more than one joist. Bracing the top and bottom flanges of steel floor joists is necessary to reduce joist movement and stiffen the floor system.

The top flanges of steel floor joists are typically braced with the sub-flooring or floor sheathing (such as plywood or OSB) as shown in Figure 4.17. When plywood or OSB is used as floor sheathing, the proper sheathing thickness shall be used; minimum thickness varies with the spacing of floor joist spacing. The local building code should be consulted when selecting the proper sheathing thickness.

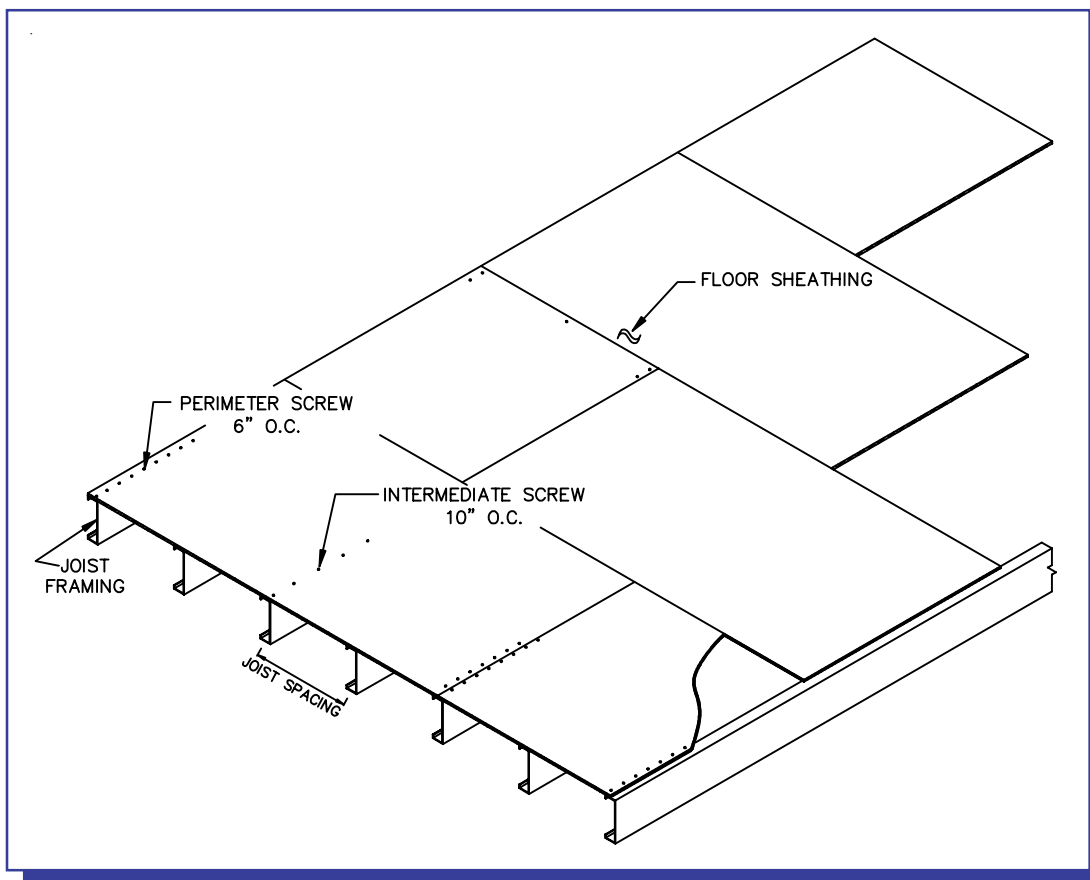

Figure 4.17. Sheathing Installation Detail

The most common methods used to brace the bottom flanges of CFS joists are X-bracing (or bridging), solid blocking, flat-straps and solid blocking, or gypsum board. Other propriety bracing methods may be available. When blocking is required, it is usually spaced at 12 feet (3.7 m) on center along the joist span. If a gypsum wall board ceiling is applied, blocking is not required.

X-Bracing consists of installing diagonal braces between pairs of joists. The braces are fastened to the joists with a minimum one #8 self-drilling screw at each end as shown in Figure 4.18.

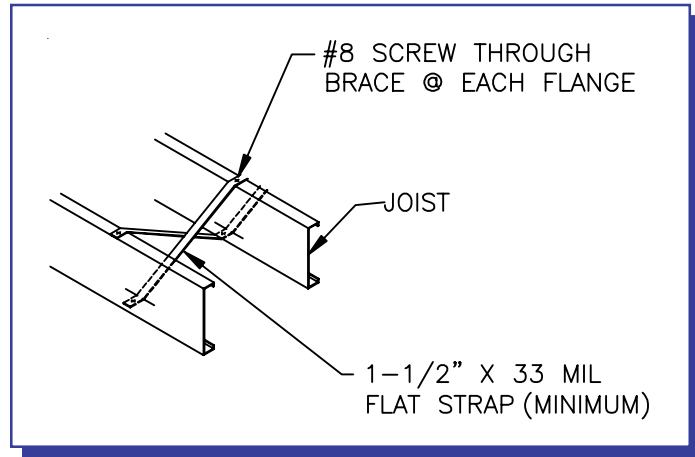

Figure 4.18. X-Bracing Detail

Flat-Strap and Solid Blocking consists of a continuous flat strap installed perpendicular to the floor joists running from one end of the floor system to the other. Solid blocking is installed between two adjacent floor joists in line with the flat strap. The solid blocking is fastened to the joists and the flat strap is fastened to the blocking with two #8 screws. The flat strap is also fastened to the bottom flange of each joist with minimum one #8 screw. Steel straps should be at least 1-1/2 inches (38 mm) in width and 33 mils (0.84 mm) in thickness. Blocking or bridging (X-bracing) is typically installed between joists at a maximum spacing of 12 feet (3.7m) measured along the continuous strapping (perpendicular to the joist run). Blocking or bridging should also be located at the termination of all straps unless the end of the strap is solidly anchored to a wall or column. In lieu of using a continuous strap, solid blocking may be installed in every other joist bay.

The blocking may be fastened to the joists as shown in Figures 4.19 through 4.21. Figure 4.22 shows a prefabricated bracing method used for the TradeReady® floor system.

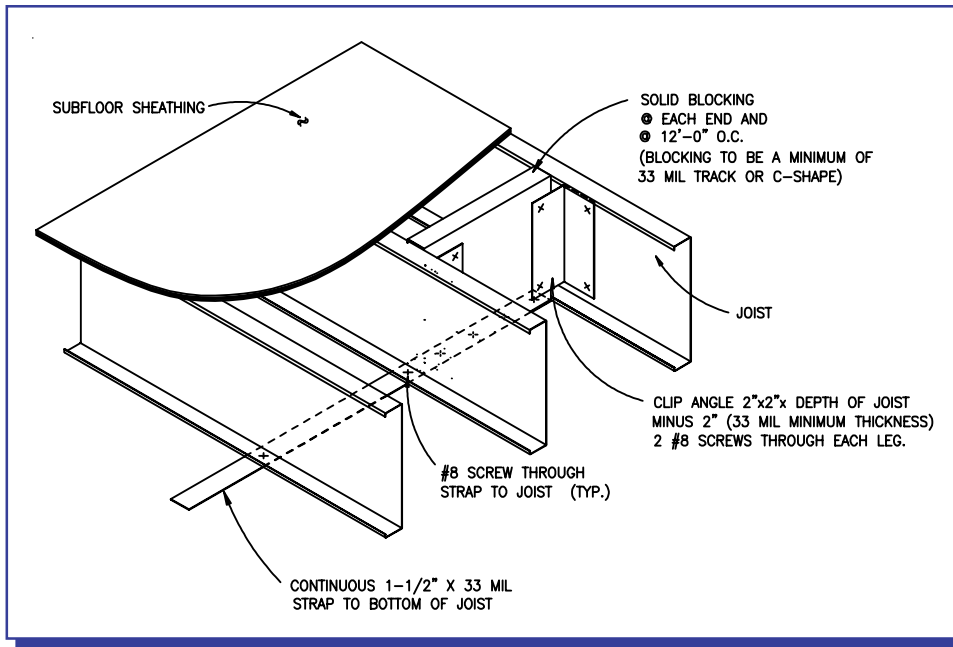

Figure 4.19. Solid Blocking Detail

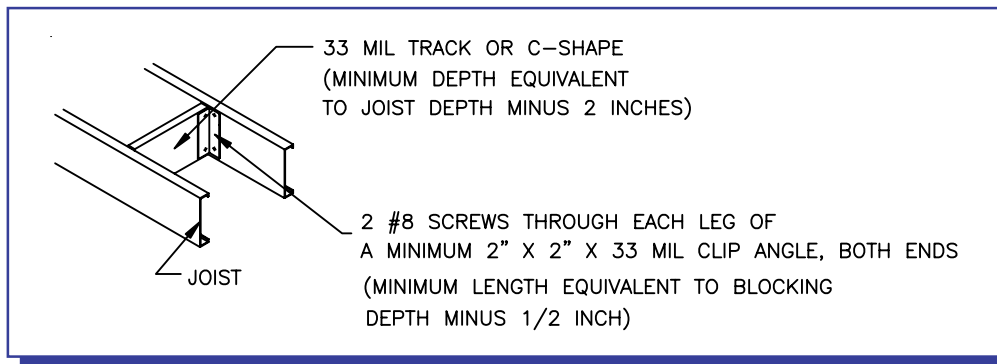

Figure 4.20. Solid Blocking Connection Detail

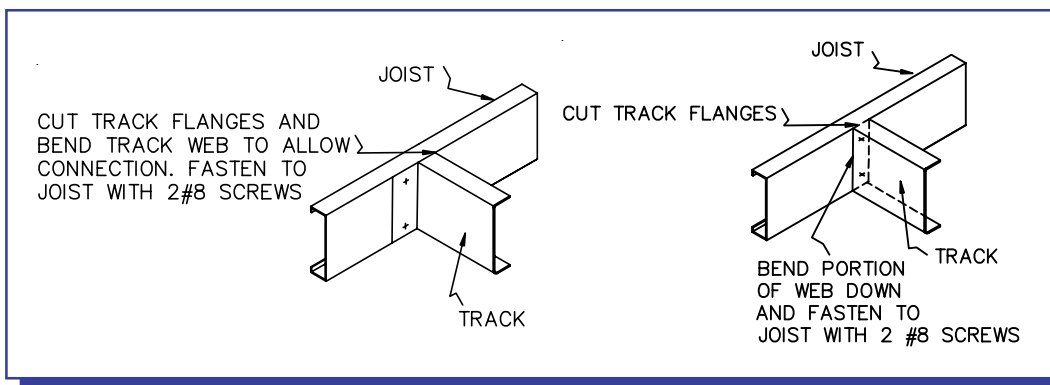

Figure 4.21. Solid Blocking Alternate Connection Detail

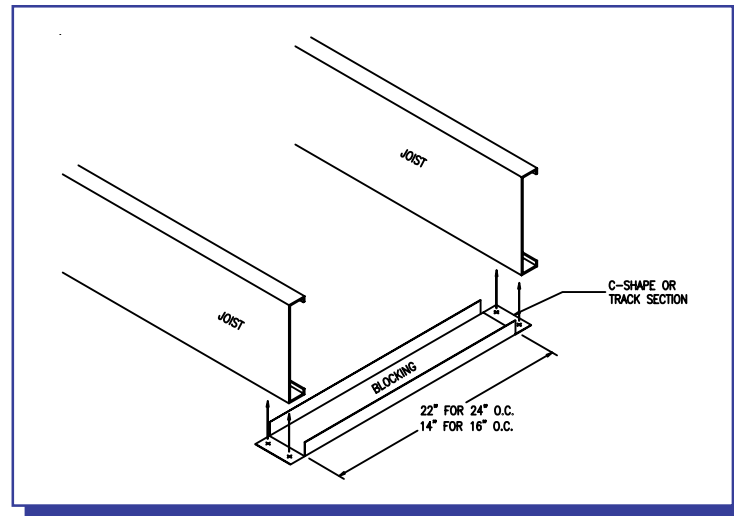

Figure 4.22. TradeReady® Pre-Fabricated Bracing

Gypsum Board can laterally brace the bottom flanges if installed with minimum #6 screws in accordance with local building code requirements as shown in Figure 4.23.

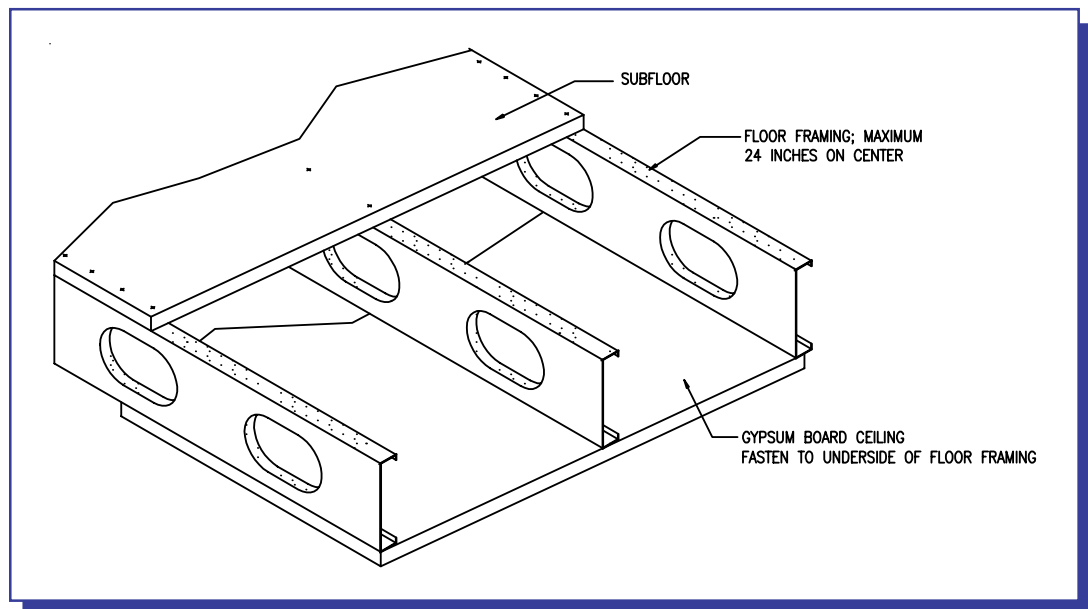

Figure 4.23. Gypsum Board Bracing Bottom Flanges

CFS bottom flange bracing (lateral bracing) need only be installed when joist spans exceed 12 feet (3.7 m) and when a gypsum board ceiling finish is not applied. The blocking does not improve floor stiffness, it merely prevents the floor from failing by twisting of the joists under extreme loads [6].

Builders' Guide to Residential Steel Floors

Web Stiffeners

Web stiffeners, where required, are fabricated and installed in accordance with Chapter 3. Floor span tables are provided for joists with and without web stiffeners. CFS floor joists having walls or other structures bearing on top of the joist ends should have web stiffeners installed at the bearing locations (i.e., joists are installed on top of a foundation wall and also support a bearing wall). CFS floor joist span tables without web stiffeners can be used when the floor joists do not support any loading other than the floor dead and live loads (i.e., joists are attached to the side of a concrete wall or to a ledger board). Figures 4.24 through 4.26 show different methods of fastening web stiffeners to CSF steel joists and to the TradeReady® floor system.

Web stiffeners should be installed for all joists at points of high concentrated loads (such as at a bearing wall location).

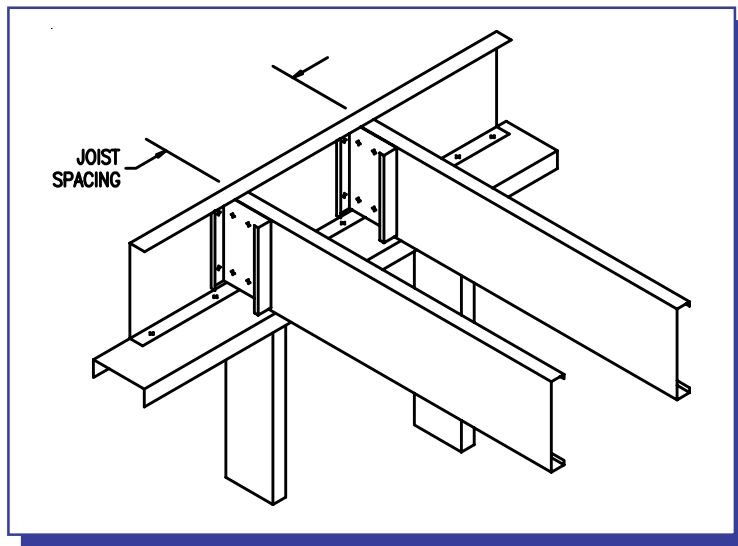

Figure 4.24. Web Stiffener Connection Through Flanges

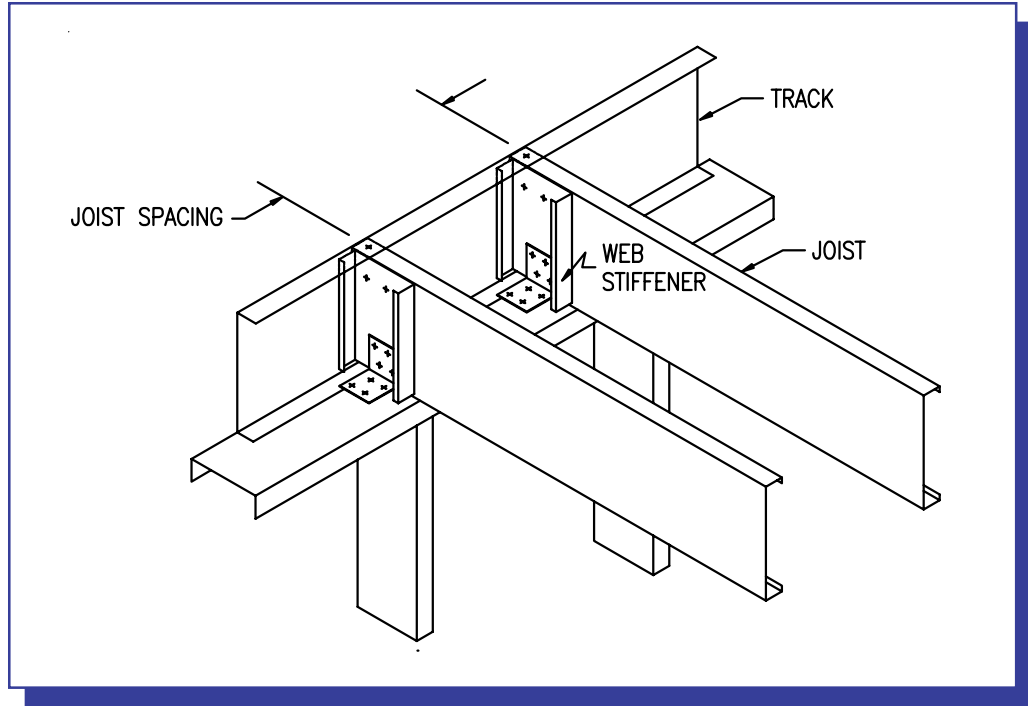

Figure 4.25. Web Stiffener Connection Through Clip Angles

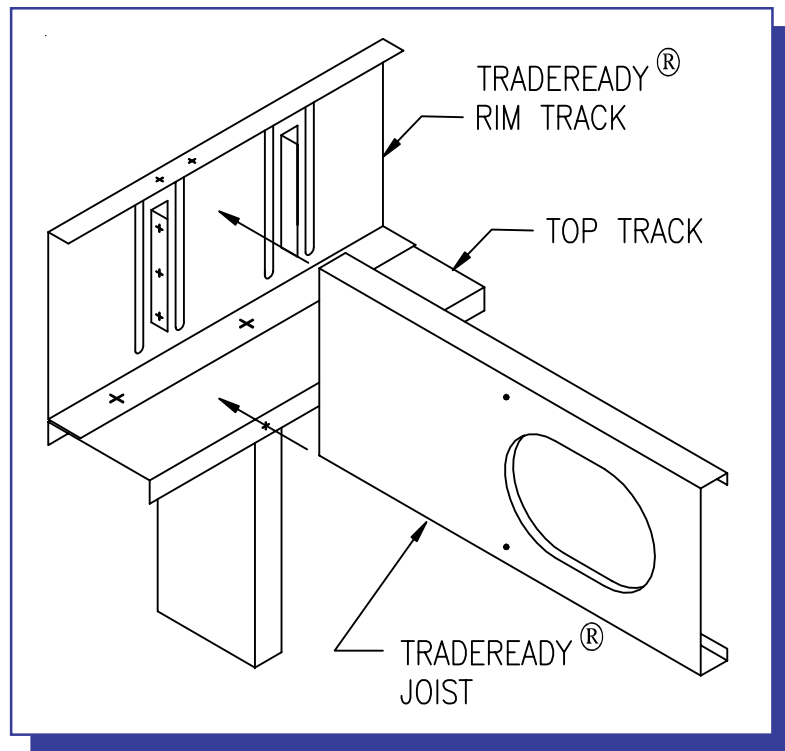

Figure 4.26. TradeReady® Joist to Rim Track Connection with Built-in Stiffener

Builders' Guide to Residential Steel Floors

Floor Cantilevers

Floor cantilevers are often used to create more floor space inside the house and to accommodate desirable architectural features. Floor cantilevers can be located on the first floor or the second floor of two-story construction. Cantilevered floor joists must be anchored to foundations or load bearing walls as shown in Figures 4.27 through 4.30 and Table 4.3. Solid blocking must be installed between joists at every other joist for cantilevered floors. Solid blocking must be attached to each joist web with a minimum of four #8 screws at each end. Approved design is required for cantilevered areas supporting uniform live loads greater than 40 psf (1.92 kN/m²) or when roof snow loads exceed 30 psf (1.44 kN/m²).

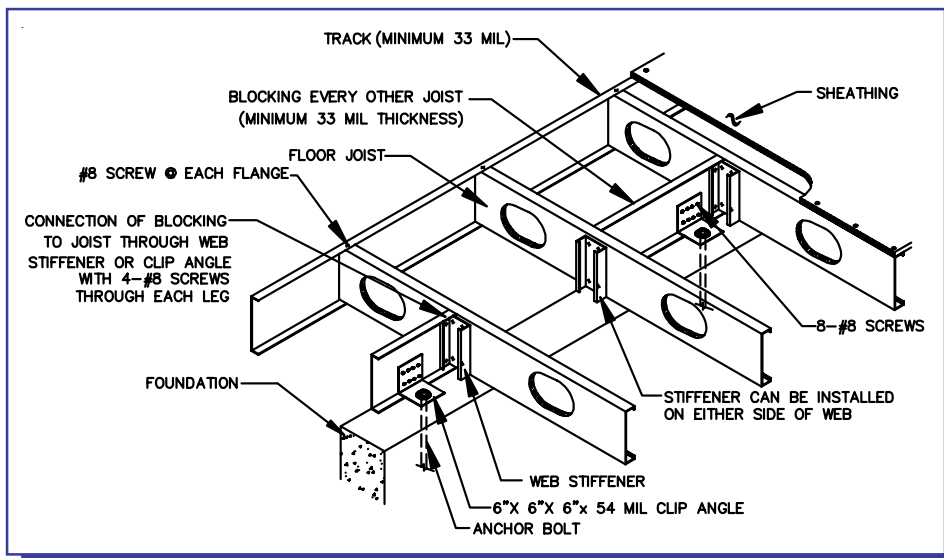

Figure 4.27. Floor Cantilever to Foundation Connection Detail

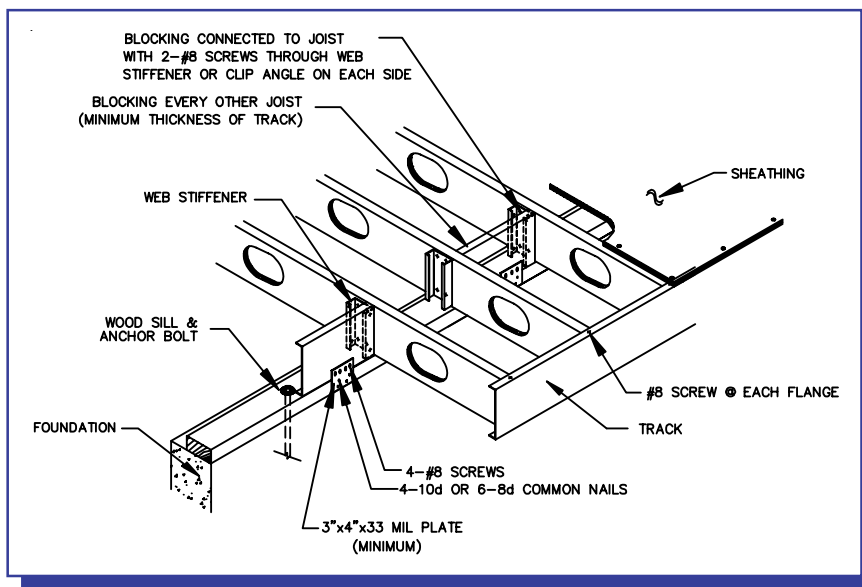

Figure 4.28. Floor Cantilever to Wood Sill Connection Detail

Builders' Guide to Residential Steel Floors

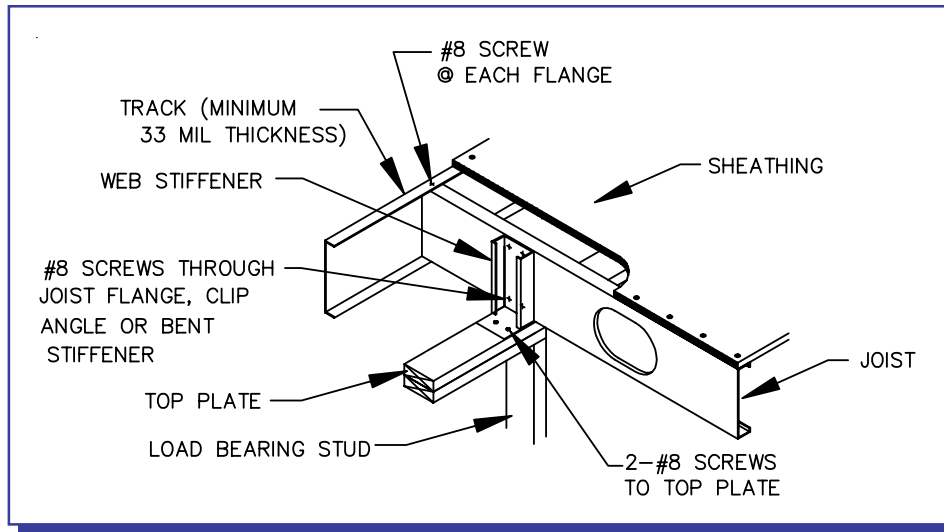

Figure 4.29. Floor Cantilever to Load Bearing Wall Connection Detail

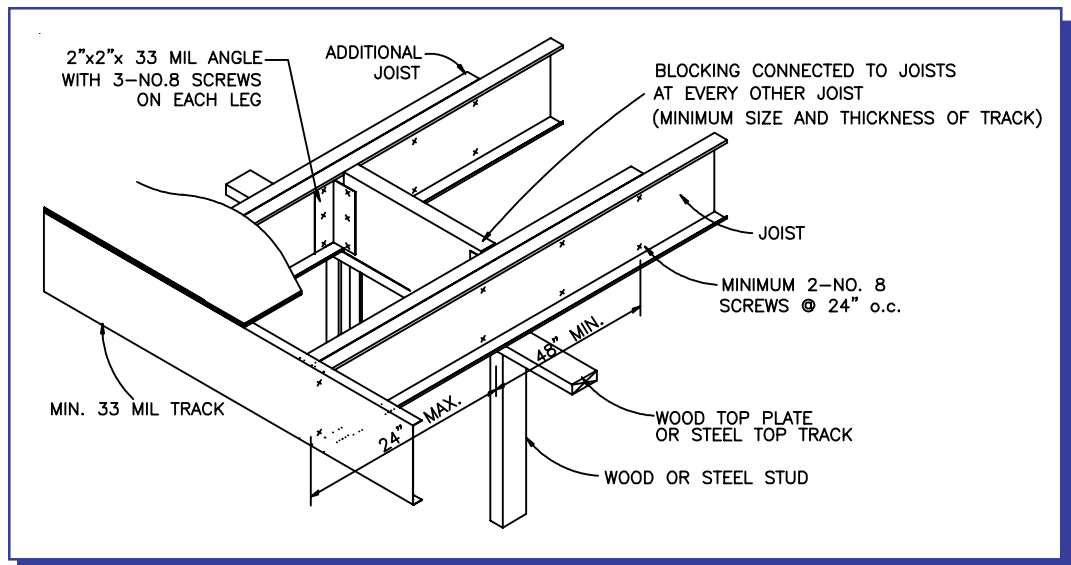

Figure 4.30. Second Floor Cantilever Connection Detail

One Story or Second Floor of Two Story Construction

Floor joists of second floor of a two-story building or the first floor of a one-story building are permitted to be cantilevered (overhang) up to 24 inches (610 mm) provided that the cantilevered floor supports interior floor and exterior wall loading only (i.e., not an exterior balcony).

Two Story Construction

Floor joists on the first floor of a two-story building are permitted to be cantilevered (overhang) up to 24 inches (610 mm) provided that the cantilevered floor supports interior floor and exterior wall loading only and all cantilevered joists are doubled (nested or back-to-back); refer to Figure 4.30. The doubled cantilevered joists must extend a minimum of 4 feet (1.2 m) towards the interior of the building and must be fastened together with a minimum of two #8 screws spaced at 24 inches (610 mm) on center through the webs (for back-to-back) or flanges (for nested joists). Single joists in lieu of double joists are permitted for cantilevered floors supporting a floor and roof load when subjected to roof live or snow load not greater than 15 psf (0.72 kN/m²).

Splicing of Steel Floor Framing Members

Joists

Floor joists are the main horizontal structural members in the floor and their structural integrity is essential to the strength of the entire house. Splicing the joists weakens the structural integrity of the floor if the splice is not properly engineered; therefore, splicing of floor joists and other structural members is not permitted without an approved design.

Tracks

Splicing of tracks is necessary (i.e., when one section of the track is not long enough to extend the whole length or width of the floor). Floor tracks and rim joists are non-load-bearing members and are permitted to be spliced. Splicing of tracks should be done in accordance with Figure 4.31. A minimum of 4- #8 screws should be applied on each side of the splice.

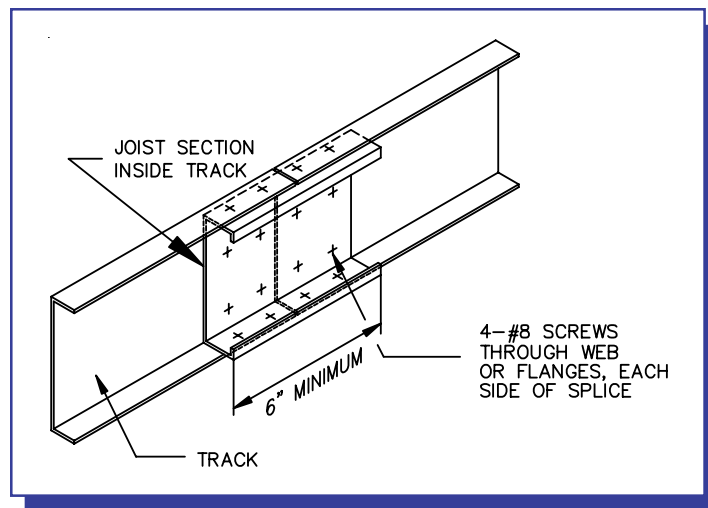

Figure 4.31. Track Splice Detail

Framing of Floor Openings

Floor openings are commonly required to accommodate stairs, chimneys, and fireplaces. Cutting through joists to make the openings considerably weakens the floor frame; therefore, openings in floors must be framed with header and trimmer joists as illustrated in Figures 4.32 and 4.33 to properly transfer loads. Header joist spans should not exceed 8 feet (2.4 m) in length unless by an approved design. Header and trimmer joists are fabricated from joist and track sections, with a minimum size and thickness as required for the floor joists. Each header joist should be connected to trimmer joists with a minimum of four 2 inch x 2 inch (51 mm x 51 mm) clip angles as shown in Figures 4.32 and 4.33. Each clip angle should be fastened to both the header and trimmer joists with four #10 screws evenly spaced on each leg of the clip angle. The clip angles should have a thickness not less than that of the floor joist. Figure 4.34 shows an opening framed with TradeReady® joists.

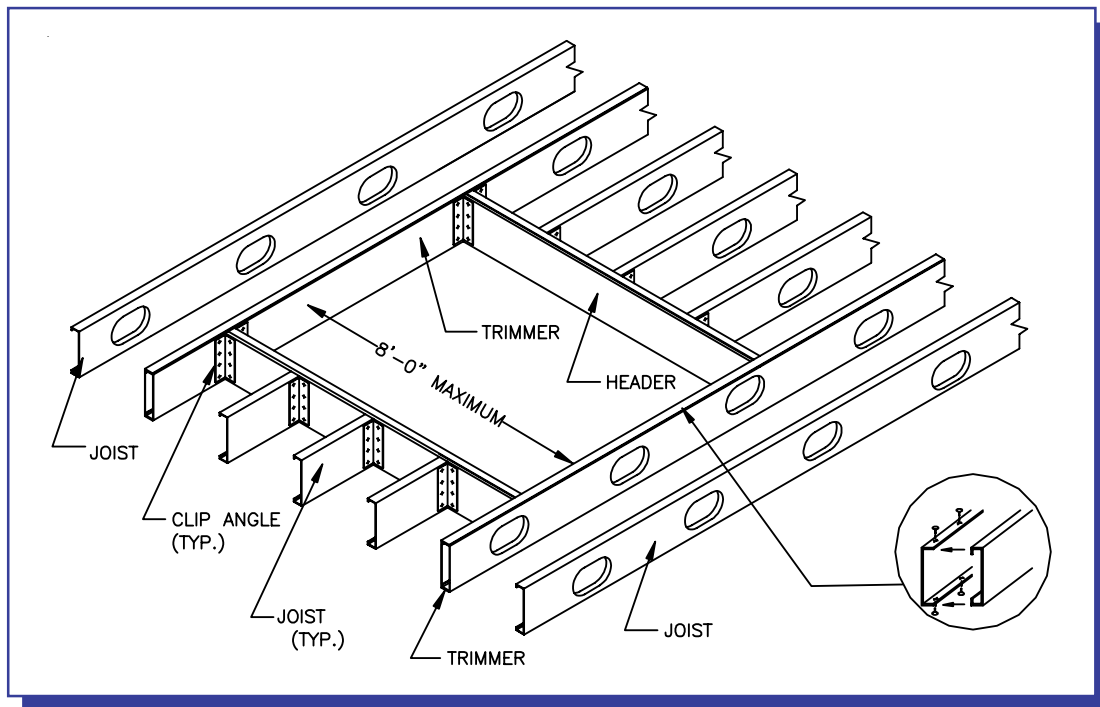

Figure 4.32. Floor Opening Detail

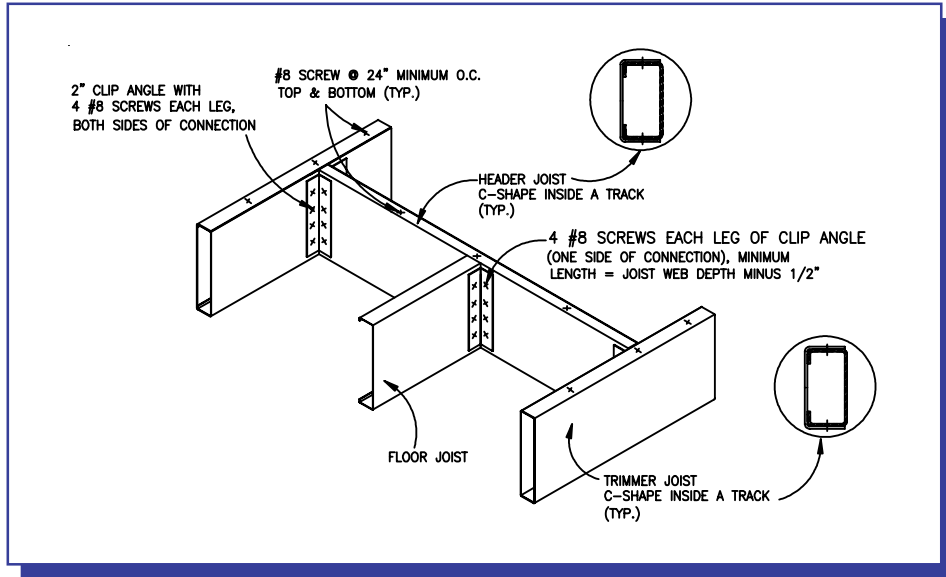

Figure 4.33. Floor Header to Trimmer Connection Detail

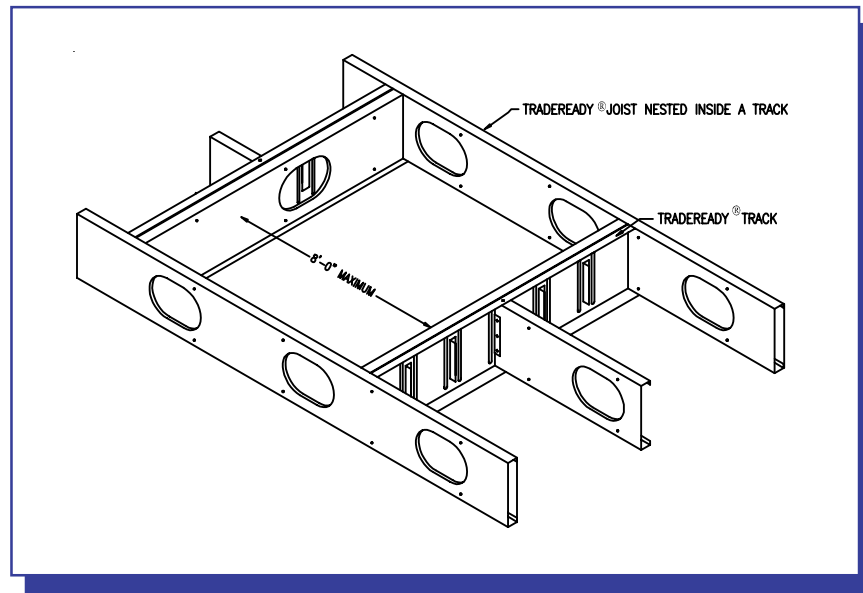

Figure 4.34. TradeReady® Floor System Opening Detail

Framing Stairwells

Stairwell openings are framed as described above in the framing of floor openings section. Stairwell headers and footers are typically fastened with #12 or #14 screws for additional strength. Clip angles, 3-inch x 3-inch (76 mm x 76 mm), are also used to connect header and trimmer joists to joists and tracks.

Non-Load Bearing Walls Parallel to Joists

Figures 4.35 and 4.36 provide typical connection details for framing non-load bearing walls parallel to floor joists.

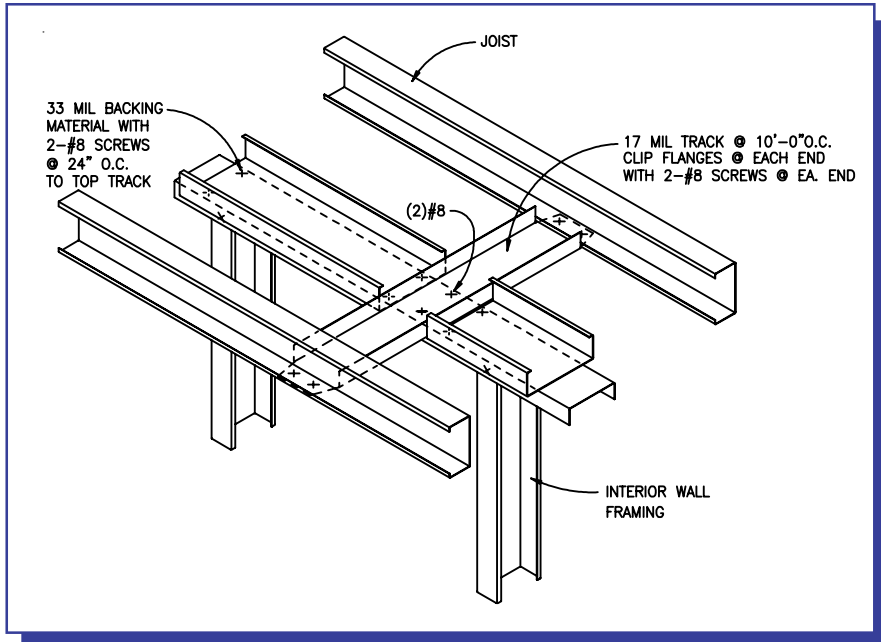

Figure 4.35. Steel Interior Non-Load Bearing Wall Parallel to Joist

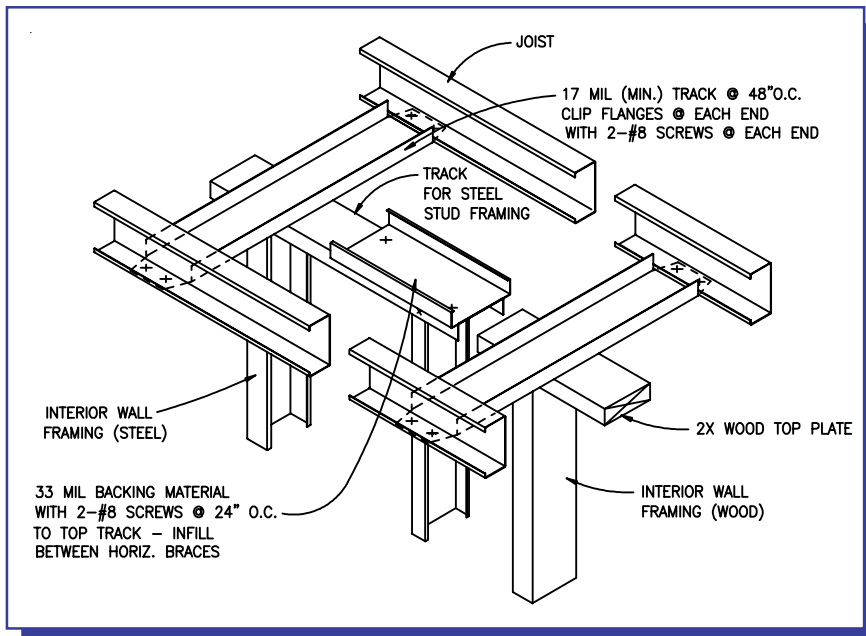

Figure 4.36. Wood Interior Non-Load Bearing Wall Parallel to Joist

References

- [1] *Prescriptive Method for Residential Cold-Formed Steel Framing*, Second Edition. Prepared for the US Department of Housing and Urban Development, the American Iron and Steel Institute, and the National Association of Home Builders, by the NAHB Research Center, Inc., Upper Marlboro, MD, September 1997.
- [2] *Innovative Residential Floor Construction: Innovative Residential Floor Construction: Structural Evaluation of Steel Joists with Pre-Formed Web Openings*, Prepared for the US Department of Housing and Urban Development, Dietrich Industries, Inc., and the National Association of Home Builders, by the NAHB Research Center, Inc., Upper Marlboro, MD, March 1999.
- [3] *Innovative Residential Floor Construction: Horizontal Diaphragm Values for Cold-Formed Steel Framing*, Prepared for the US Department of Housing and Urban Development, Dietrich Industries, Inc., and the National Association of Home Builders, by the NAHB Research Center, Inc., Upper Marlboro, MD, March 1999.
- [4] *Cold-Formed Steel Design Manual: Specification for the Design of Cold-Formed Steel Structural Members*, 1996 Edition. American Iron and Steel Institute (AISI), Washington, DC, June 1997.
- [5] *Residential Steel Framing, National training Curriculum*, First Printing, American Iron and Steel Institute (AISI), Washington, DC, May 1998.
- [6] Kraus, C. A., and Murray, T. M. (1997), *Floor Vibration Criterion for Cold-Formed C-Shaped Supported Residential Floor Systems*, Report No. CE/VPI-ST 97/04. Virginia Polytechnic Institute and State University, Department of Civil Engineering, Blacksburg, VA, February 1997.

Trade Installations

Introduction

CFS floor framing can be integrated easily and successfully with conventional materials used in house construction. Under most circumstances the working methods of the various trades are similar to those followed in constructing wood framed homes. The final finish will be indistinguishable from the finish on a traditional wood house.

Tradesmen will require minor changes in their techniques when working with steel floor framing. For the most part a change in technology from traditional nailing and screwing to power, self drilling fasteners, or pneumatic nail pins is all that is required.

Floor Finishes

There are no changes to the normal working practices for installation of floor finishes when working with a steel framed floor surfaced with wood structural panel sheathing. However, finishes that require mechanical fastening (i.e., hardwood flooring) may experience some fastening problems (i.e., interference with steel joists) depending on the thickness of subflooring and type of fastener used. The fastener manufacturer should be consulted.

Steel Tip

- Include your subcontractors early in the project. Before the initial steel framing begins, especially if steel framing is not common in the region, a plumber, electrician, and HVAC installer willing to work with steel should be located.
- Help train the subcontractors. They may be working with steel for the first time and may struggle with the learning curve. As a result, they may charge more to cover the extra time they need to do the job.
- Use experienced plumbing, electrical, and HVAC subs. Some commercial subcontractors have worked with steel framing for many years.

Plumbing

Plumbing installation should comply with the applicable plumbing code. Plumbing lines are installed in a similar manner to wood-framed construction. Copper pipes should be separated from the steel framing by plastic grommets or other approved methods. A list of appropriate types of plastic insulators and grommets for pre-punched web holes is generally available from the steel supplier. See Figure 5.1 for routing of drainpipe through the TradeReady® Joist.

Steel Tip

Plumbing lines for the kitchen, laundry, bathrooms, and water heaters should be clustered together as close as possible on the plan to minimize the number and length of piping runs.

Steel Tip

Make sure all prepunched joist holes line up.

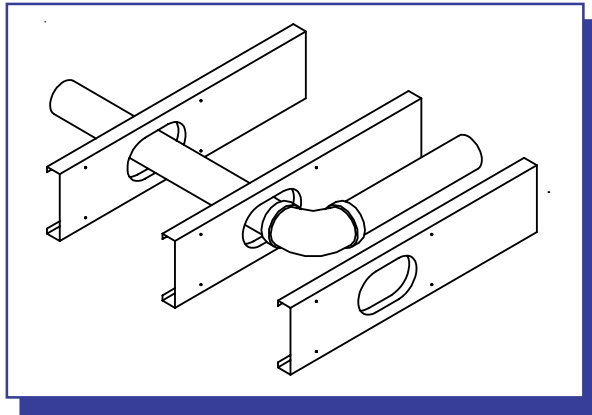

Figure 5.1. Drain Pipe Installation

Hangers

Plastic and copper pipes installed in floor framing must be attached and secured to floor joists. Hangers should be attached to steel using a minimum #6 self-piercing screw in 18 mil steel and a self-drilling #8 screw for thicker steels. Copper hangers should not be attached directly to steel because copper and steel are dissimilar materials and corrosion by electrolysis may occur (see Chapter 3). Plastic type hangers or steel hangers should be used.

Isolators

Copper and plastic pipes should be protected from sharp edges when passing through steel joists. As mentioned above, copper pipes should be protected from electrolysis by using plastic pipe isolators and clamps, foam insulators or grommets.

Plumbing Fixture Attachment

Plumbing fixtures can be attached with low-profile head screws with a sharp point for 18- and 27-mil (0.46 mm and 0.69 mm) steel and a self-drilling point for 33 mil (0.84 mm) and thicker steel. Contact of galvanized screws to copper fittings should be avoided.

Electrical

Electrical installations must comply with the National Electric Code (NEC) plus any local regulations. Electrical wires and cables must be properly secured and protected from sharp edges. Bushings are used in holes with raw or sharp edges, to prevent damage to cables. Bushings are not required if the holes are swaged or flared to remove raw edges. See Figures 5.2 and 5.3 for routing of romex wire through TradeReady® floor.

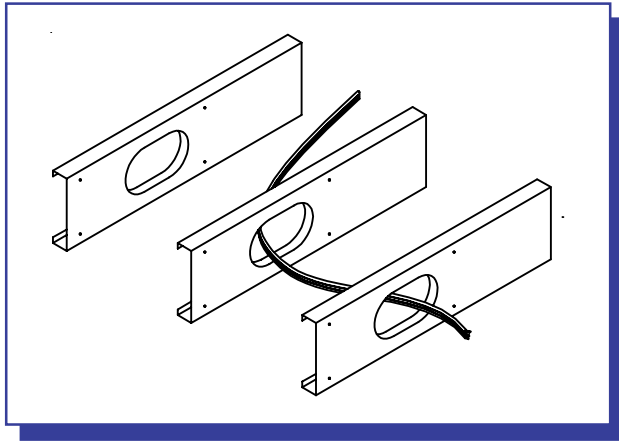

Figure 5.2. Electrical Wires Through Floor Joists

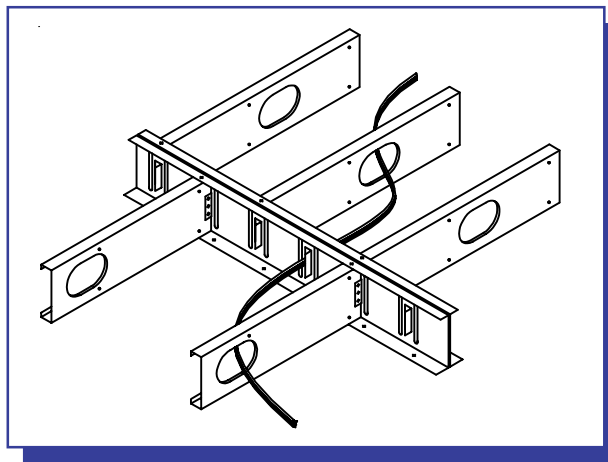

Figure 5.3. Electrical Wires Through Floor Joists and Rim Track

Securing Wiring

Nylon zip ties are typically used to secure multiple wires so they can be tensioned and protected from damage. Standoff clips are also used to secure wiring.

HVAC Systems and Duct Work

HVAC installation should comply with the applicable mechanical and energy codes. Figure 5.4 shows a round duct installed through a folded opening in a Joist floor.

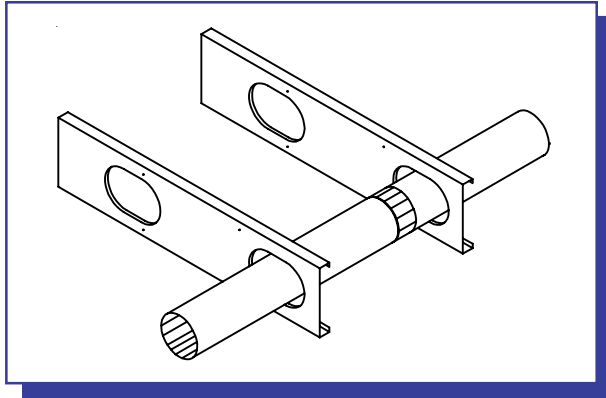

Figure 5.4. Round Duct Through Joists with Folded Web Openings

Hangers

Hangers for ducts are attached to steel floor framing with $\frac{3}{4}$ -inch, #8 self-drilling screws. Ducts should be isolated from the floor joists by rubber or foam packing to prevent noise or nuisance vibrations.

Bulkhead Framing

Bulkheads will be needed for drop down ceiling ducts. Bulkheads are framed as a non-load bearing assembly. They can be easily framed using 33 mil (0.84 mm) or thinner C-shaped studs and tracks.

Steel Tip

- Heating and cooling equipment should be placed in a central location on the floor plan to provide for good air distribution and to minimize the number and length of duct runs. The longer the ducts, the greater the loss of energy.
- Vertical or horizontal chases may be necessary for ducts, flues, or returns. The architect and framer should provide for them.

Insulation

Insulation of steel-framed floors should comply with the applicable energy code. Different parts of the United States have different energy requirements. The following is a list of the widely used energy codes in the U.S.:

- ICC *Model Energy Code* [1]
- American Society of Heating, Refrigeration and Air-Conditioning Engineers (ASHRAE) Standard 90.2 [2].
- California's Title 24 [3].

Energy codes require steel-framed homes to meet certain energy performance criteria, usually specified in an “R” factor. The “R” value provides an indication of the effectiveness of insulation at holding warm or cold air inside. All types of insulation are compatible with steel framing (i.e. batt insulation, spray applied foam, foam plastic boards, etc.). Thermal performance of steel framing is not well understood or documented. Therefore, insulation amounts in current energy codes for wood framing will not necessarily give equivalent results in steel framing. If a floor is required to be insulated (i.e., over an unconditioned crawl space); then insulation should be installed following this section.

Floor insulation should be secured between steel joists in the same manner as for wood joists. Strapping, ties, or other permanent support methods can be used to secure the insulation between the joist cavities. Permanent support should not be necessary when gypsum board is installed.

Insulation should be installed between floor joists that span above unheated living spaces and crawl spaces. Insulation should also be installed around the joists or tracks, between the joists, and along the endwall.

When batt type insulation is installed between the cavity of joist members it is important to select fiberglass batt insulation that occupies the full width of the cavity (between webs) so there are no air spaces in the cavity. While batt insulation may friction fit between the joists, duct tape may also be used to hold the insulation in place until the gypsum board is installed. Figure 5.5 shows the installation of batt insulation between two CFS joists.

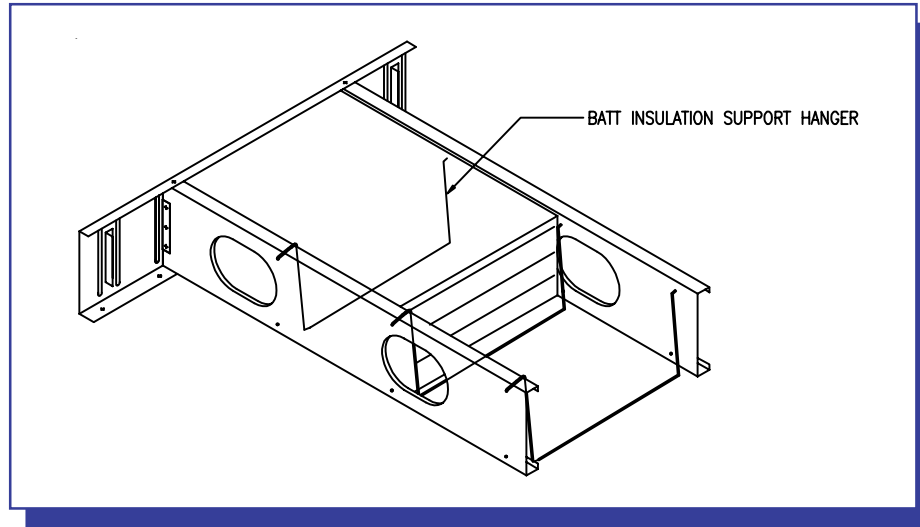

Figure 5.5. Installation of Batt Insulation Between CFS Joists

References

- [1] *Model Energy Code*, International Code Council, Falls Church, VA, 1995.
- [2] ASHRAE Standard 90.2, *Energy-Efficient Design of New Low-Rise Residential Buildings and User's Manual*, American Society of Heating, Refrigeration and Air-Conditioning Engineers (ASHRAE), Atlanta, GA, 1993.
- [3] California Code of Regulations Title 24, *California Energy Efficiency Standards for Residential and Non-Residential Buildings*, California Energy Commission, Sacramento, CA, July 1995.

General Recommendations

Introduction

The general recommendations and guidelines provided in this chapter supplement the requirements in this document and are considered good practices. These recommendations and guidelines should not be considered comprehensive or mandatory. Manufacturer's catalogs, recommendations, and other technical literature should also be consulted.

Floor Joist Installation

The following sequence is generally used when installing CFS floor joists: Joist layout, perimeter track installation, and perimeter track to joist attachment. The following sections further describe each step in the installation sequence. If in-line framing is required (see Chapter 4), then the floor layout will need to be planned in coordination with the stud layout in the wall below. If this is a problem, then use a load-bearing top plate consisting of double 2x top plates as shown in Figure 6.1. There are several options for floor-to-wall connections; refer to Table 4.3 of Chapter 4.

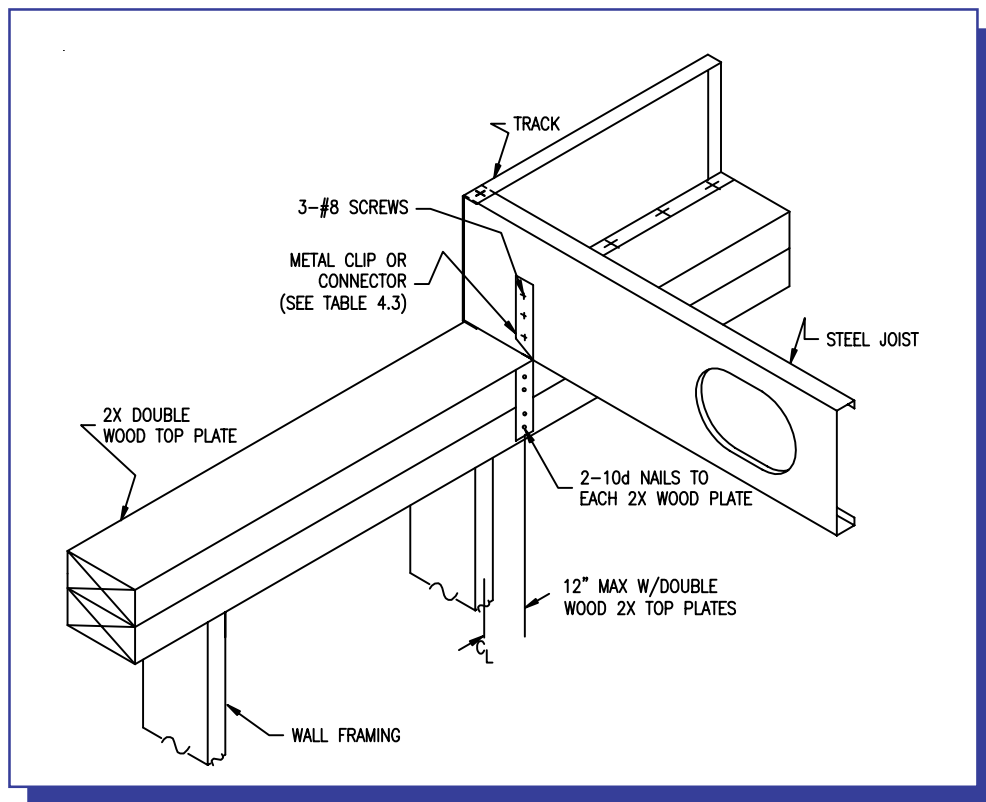

Figure 6.1. Floor Joist to Double 2x Top Plates

Joist Layout

Joist layout for the first floor starts after the foundation work has been completed. Joists, tracks, beams, and columns should be available on site for proper joist installation. Perimeter tracks should be marked for location of joists. This step can be eliminated if the TradeReady® joist system is used because the joist attachment locations are pre-formed, as shown in Figure 6.2.

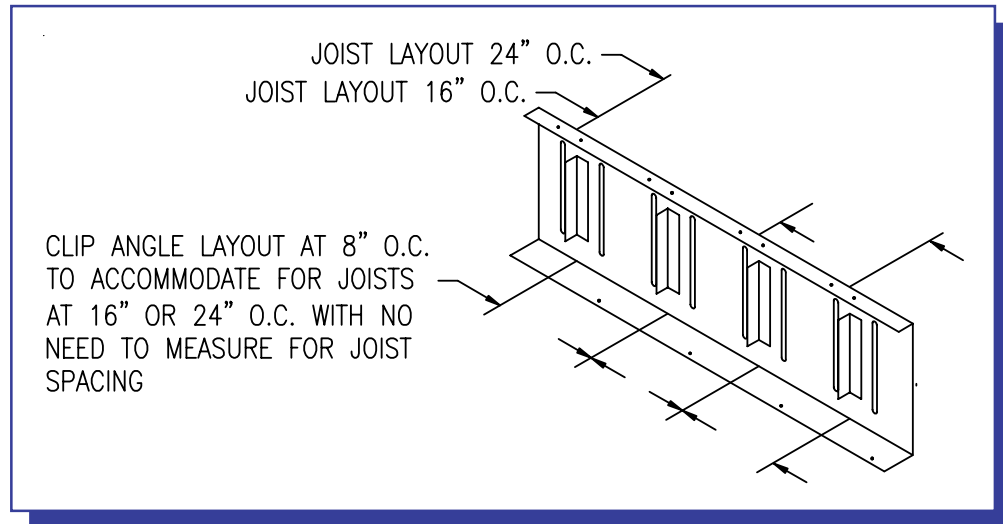

Figure 6.2. TradeReady® Rim Track

Joists should be laid out facing the same direction. When it is necessary to cut floor joists, make sure all cuts are made on the same end of all joists so that joist web holes remain at the same location and aligned from one joist to the next.

Perimeter Track Installation

The perimeter track (also called rim joists or runner track) can bear on top of the foundation or be anchored directly to the side of the foundation (recessed floor). The most common method of installation is to arrange floor joists on top of the foundation. Before installing perimeter tracks on foundation, insert a strip of felt or building paper between the track and the concrete to help isolate the foundation wall from the metal particularly if there is a potential for the concrete to wick moisture up from the ground.

Perimeter Track to Joist Attachment

After marking, securing, and aligning the perimeter tracks, the steel joists are installed one at a time. Each joist is clamped to the track at both ends and secured with screws through the flanges or web stiffeners (low profile screws should be used on top flanges to allow for a smooth sub-floor application), as shown in Figure 6.3. Floor joists can be slightly twisted to allow fitting between tracks. Joists, however, should not be forced into position or twisted into opposite directions at each end because they may bend and become permanently deformed. The joist should fit snugly at each end into the track with a gap no greater than ¼-inch (6 mm). CFS floor joists can be attached to steel I-beams with No. 12 drill-point screws through the flange.



Figure 6.3. Fastening Track to Joist

Floor Sheathing Application

Once the steel floor frame is complete, the floor sheathing is installed. Possible sheathing materials include plywood, oriented-strand-board (OSB), particleboard planks, boards, or a non-wood material. Regardless of the material used, all sheathing should be smooth, securely fastened, and provide a suitable base for the final floor covering. Wood structural panels are the most commonly used sub-flooring material for residential construction and this guide is based on the use of that material.

Wood structural panels add rigidity to the floor, they are easily installed, and they provide a sound base for the floor covering. Plywood and OSB are produced with tongue-and-groove edges to improve floor performance. They come in sheets that are nominally 48 x 96 inches (1219 mm x 2438 mm), but measure slightly less to allow for expansion.

Plywood is installed with its face grain perpendicular to the floor joists. Lay the sheets with the long dimension across the joists and stagger the ends of adjacent sheets. The partial sheets used to begin every other row can be 1/2 or 1/3 of a sheet, depending on the overall dimension of the floor.

Nearly all floor-sheathing problems are due to incorrect installation. Fasten panels with bugle head screws spaced on maximum 6-inch (152 mm) centers at supported panel ends and edges. At the intermediate supports, fasten the panels 12-inches (mm) on center. Fasteners should be nominally 3/8 inch (9.5 mm) from the panel edges. Following these simple construction steps results in the best performance and minimizes callbacks.

- Position the panel carefully and use a few fasteners at all corners, if needed, to square the panel on framing and hold-in place.
- Install the fasteners at one panel end, as shown in Figure 6.4.



Figure 6.4. Fastening Panel Ends

- Install intermediate fasteners, starting at the panel edge. Use a chalkline or straight edge to align the fasteners on the framing. Fasten the panels in rows across the panel width. Continue this sequence along the length of the panel, as shown in Figure 6.5. This procedure keeps bulges from building-up in the panels.



Figure 6.5. Fastening Sheathing to Steel Joists

- Stand on the panel near the fastener location to ensure contact with the frame when the fasteners are driven. Drive the fasteners flush with the panel surface.
- For improved performance and “feel” consider thicker sheathing panels.
- When installing the panels, a 1/8-inch (3.2 mm) space between adjacent panel ends and edge joints is recommended, unless the panel manufacturer indicates otherwise.
- It is important to leave space between the sheets to permit expansion. Oriented-strand-board (OSB) is made under extreme heat and pressure. They are palletized in this process and thus may not have the opportunity to absorb moisture and expand to its “lifetime” dimensions prior to installation.
- Visually check the subflooring surface for flatness between the floor-framing members. Also visually check the subflooring end and edge joints for evenness or variation in panel thickness that may telegraph through the underlayment. If necessary, sand the subflooring joints with a commercial floor sander to smooth surfaces in the vicinity of the joints.

Curved Floors

Curved floors are often specified in the architectural drawings, as consumers are demanding more and more intricately designed homes. Curved floors require the rim track to be bent and the joists to be cut to different sizes to properly fit between the flanges of the curved track. Curved tracks may be ordered curved for a specified curve, or field cut by snipping the flanges at predetermined intervals. Curved tracks are typically available through specialty companies that provide a clean and neatly bent track to an exact radius.

Fire Safety

Building codes generally require homes to be designed such that, in case of a fire, there is sufficient time for occupants to leave the building safely. Protection is usually provided by surfaces with low flame-spread rates and barriers that contain the fire within a small space for a minimum specified time. Fire rating of a floor assembly is a measurement that indicates how long the assembly will resist the spread of fire while maintaining structural integrity. Fire resistance ratings are expressed by the number of hours that a floor assembly can maintain its integrity while containing the fire, smoke, and temperature of a working fire

Fire ratings of floor assemblies are given in terms of the time to reach one of the following limiting states:

- Elements collapse (stability),
- Cracks develop allowing flames to pass through (integrity), or
- Temperature rise of 250 °F on the non-fire-exposed surface (insulative capacity).

Building codes provide fire endurance requirements for floor construction. The Gypsum Association's *Fire Resistance Design Manual* [1] and the UL's *Fire Resistance Directory* [2] are the most commonly used documents for CFS floor fire ratings. The Light Gauge Steel Engineer's Association *Technical Note No. 420* [3] provides a comprehensive list of resources for fire rated steel assemblies. Fire rated floor systems are generally only required in multi-family and commercial construction.

Fire and Draft Stops

Fire stops and draft stops may be required for some CFS floor systems in multi-family housing and around a mechanical chase. Fire stops and draft stops prevent the fast movement of flame and gases through concealed spaces to other parts of the building. Fire stops are usually required in stud spaces at floor and ceiling levels to prevent the spread of fire in the vertical direction in concealed spaces. Fire stopping is also required at stairwell and chimney locations. Local building codes or building official should be consulted for fire stop and draft stop requirements.

Recommended Construction Methods for Controlling Sound

Fiberglass or cellulose insulation installed in floor assemblies can significantly reduce the sound transmission (i.e. increase the STC rating). STC (sound transmission class) ratings are used to measure the effectiveness of a given floor system construction in reducing airborne sound transmission. The higher the STC rating, the better the construction (i.e. noise transmission is better controlled). An STC rating of 42-50 is considered acceptable in designing CFS floors. Good construction practices can also result in significant reduction in sound transmission through CFS floors. Some of the good construction practices are listed below.

- Surface mount any ceiling fixture on resiliently mounted gypsum ceilings
- Don't use recessed type fixtures without enclosing (boxing) the fixture.
- Design pipe runs with swing arms to eliminate noise from binding due to expansion and contraction.
- Eliminate water hammer in plumbing lines (due to abrupt stopping of flowing water) by providing air chambers in the piping.
- Use resilient pads to isolate piping from floor framing and seal for air tightness.
- Adequately size water piping and valves to minimize whistling.
- Use quiet, high quality appliances (i.e. air conditioners and furnaces)
- Select quiet external ballast on fluorescent fixtures.
- Reduce the speed of flowing water by using over sized pipes and reduced pressure.
- Minimize disturbance from the noise of flowing water in pipes by developing a well-planned layout of plumbing.
- Use duct liners to quiet fan noise and the sounds of air rushing through the ducts.

Vibration Control

The joist spans given in this guide provide reasonable performance based on past experience with residential floor design. However, there may be cases where reduced vibration may be desirable. There are two approaches:

- Tighter deflection limit (use $L/600$ in lieu of $L/480$)
- Vibration criteria check (such as the criteria contained in [4]).
- Limit the mid-span deflection due to live (40 psf) and dead (10 psf) loads to a maximum of 1/2 inch.

Situations to be aware of:

- Joists bearing on a flexible beam instead of a bearing wall or foundation (flexibility of beam compounds floor vibration).
- Floors not covered with soft flooring will not dampen foot-fall impacts and will also sound noisier (this is a subjective/perception issue as much as it is a vibration issue).

Construction Guidelines

Job-Site Safety

- Always follow OSHA guidelines and safety requirements when they are applicable.
- Wear work gloves to protect hands from cuts and injuries when working with steel. Thin gloves are recommended.
- Ear protection is recommended when cutting steel with an abrasive or metal blade. Compressible foam earplugs are the best for long-term wear, although plastic plugs are easier to pop in and out.
- Safety goggles are recommended when cutting steel with a chop saw or when fastening members overhead.
- Cutting and welding galvanized steel can produce harmful fumes that can be hazardous to health and cause irritation to the respiratory system. Make sure all cutting and welding is done in a well-ventilated area.
- Use caution when working with steel in the rain. Steel members are slippery and may cause injuries if not properly handled.



- Steel may be oily from the roll forming process, resulting in joists that are slippery and very difficult to walk on. Keep this in mind before you try to use a steel joist as a plank on scaffolding or a ramp to your truck. Steel can buckle unexpectedly when loaded in a flatwise position.
- Use caution when handling steel members around electrical wires and equipment. Steel joists can easily damage electrical chords.
- To prevent electrocution hazard, always isolate steel from any source of electricity because steel is an excellent conductor of electricity.
- Steel joists will not support workers or other loads until properly installed and braced. To minimize injury, each steel joist should be properly fastened as it is erected.
- Improper storage or installation, failure to follow applicable building codes, failure to follow proper load tables, failure to use acceptable hole sizes and locations, or failure to use bearing stiffeners when required can result in poor performance.

Storage and Handling

- Joist bundles should be stored level.
- Steel joists should be protected from weather.
- Do not open bundles until time of installation. Use care when handling bundles and individual components to prevent injury to handlers or damage by forklift or crane.
- Twisting of steel joists, or applying loads to the joist when flat can damage the joist.
- Damaged steel joists should not be used.
- Never handle steel joists flat. Beginning with the unloading process, and through out all phases of construction, care must be taken to avoid lateral and torsional bending of joists, which can cause damage to the steel joists.

Steel Tip

Do not store steel joist bundles on uneven ground or in an upright position.

Joist Installation

- Follow in-line-framing layout when required.
- Use of string line, plum bob, level or transit is encouraged to ensure that the foundation is relatively “true” before beginning installation because tolerances are very critical in achieving an acceptable floor.
- Each joist member should bear the Manufacturer’s name, logo or initials, base metal thickness (uncoated), minimum specified yield strength, and minimum coating designation. Verify that you have the right material for the job.
- Track members should not be used individually for any load carrying applications without an approved design.
- Joists, tracks, and other floor-framing members should be in good condition. Bent, warped, or otherwise damaged members should be replaced.
- Bearing surfaces for joists should be uniform and level.
- Adequate temporary joist bracing should be provided until permanent bracing has been installed. Temporary construction bracing may also remain in place after permanent bracing is installed.
- All anchors, hangers, tie-downs, bearing ledgers, etc. that are part of the supporting structure should be properly placed and permanently attached before joist installation begins. No steel joist should ever be installed on anchors or ties that have temporary connections to the supporting structure.
- Web stiffeners should be installed at all concentrated load locations, and are often required at bearing points (i.e., where joist bear on bearing walls or beams).
- Loading of floor joists before bracing or sheathing is installed should be avoided.
- Heavy construction loads such as stacks of plywood, gypsum board, bricks, etc., should not be placed on floor joists before they are properly braced or without appropriately distributing the load so the capacity of the floor system is not exceeded.

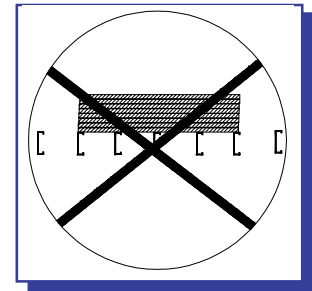

- Walking across unbraced floor systems may cause an unexpected fall.
- Check the sub-flooring for squeaks and correct as necessary.
- Allow a small gap on either end of the floor joist to keep the floor joist away from the rim joist so that the potential problem of the floor joist rubbing against the rim joist and causing a squeak in the floor is eliminated.
- When sheathing floor joists, make sure screws are driven into the top flange of each joist.

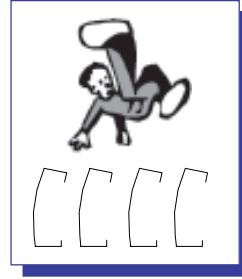

Cutting and Fastening

- Cutting methods that cause significant heating of the steel or damage to the coatings should be avoided.
- Welding, in lieu of fastening, is permitted provided that weld capacity is shown to exceed the specified screw capacity. All shop and field welds should be brushed clean and provided with a corrosion protective metallic coating.
- Screws should typically be driven through the thinner material and into the thicker material (see Figure 6.6) and extend through the steel member a minimum of three exposed threads.
- Installation drilling tools should drive screws at low speeds of 2500 RPM for screw sizes up to #10 and 1800 RPM for #12 (2500 RPM is acceptable provided that care is taken to minimize heat buildup at the screw tip).
- Pre-drilled holes for preset bolts should not be oversized more than 1/16 inch (1.6 mm) for bolt sizes up to 1/2 inch (12.7 mm) and no more than 1/8 inch for bolt sizes larger than 1/2 inch (12.7 mm) in diameter. A washer should be used between the nut and member in all bolted connections.

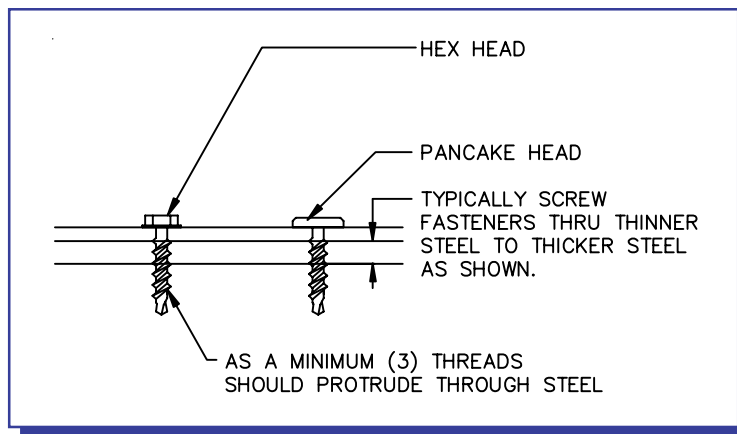

Figure 6.6. Screw Installation

References

- [1] Gypsum Association (1994), *Fire Resistance Design Manual*, 14th Edition. Washington DC.
- [2] UL (1997). *Fire Resistance Directory, Volumes 1 and 2*, Underwriters Laboratories Inc., Northbrook, Illinois.
- [3] LGSEA TN No. 420, *Fire Rated Assemblies of Cold-Formed Steel Construction*, Light Gauge Steel Engineers Association (LGSEA), Nashville, TN, 1998.
- [4] Kraus, C. A., and Murray, T. M. (1997), *Floor Vibration Criterion for Cold-Formed C-Shaped Supported Residential Floor Systems*, Report No. CE/VPI-ST 97/04. Virginia Polytechnic Institute and State University, Department of Civil Engineering, Blacksburg, VA, February 1997.

Definitions

Accepted Engineering Practice: An engineering approach that conforms with accepted principles, tests, technical standards, and sound judgment.

Approved: Approval by a code official, design professional, or authority having jurisdiction.

Blocking: Solid block or piece of material placed between structural members to provide lateral bracing as in bridging and/or edge support for sheathing.

Bridging: Cross bracing or blocking placed between joists to provide lateral support.

Buckling: A kink, wrinkle, bulge, or other loss in the original shape of a member due to compression, bending, bearing, or shear loads.

C-Shape: A basic cold-formed steel shape used for structural framing members (such as joists). The name comes from the member's "C" shaped cross-sectional configuration consisting of a web, flange and lip. It is also called a "C-section". The figure below illustrates and defines the different parts of the C-Shape. Web depth measurements are taken to the outside of the flanges. Flange width measurements also use outside dimensions.

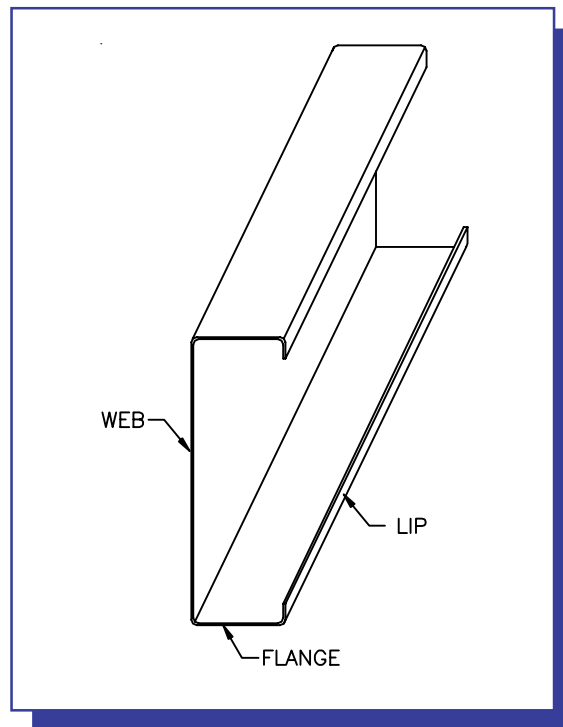

Clip Angle: An L-shaped short piece of metal (normally with a 90-degree bend) typically used for connections.

Cold-forming: A process where light-gauge steel members are manufactured by (1) press-braking blanks sheared from sheets or cut length of coils or plates, or by (2) continuous roll forming of cold- or hot-rolled coils of sheet steel; both forming operations are performed at ambient room temperature, that is, without any addition of heat such as would be required for hot forming.

Design Professional: An architect or engineer, registered or licensed to practice professional architecture or engineering, as defined by the statutory requirements of the laws of the state in which a project is to be constructed.

Flange: The part of a C-Shape or track that is perpendicular to the web.

Flat Strap: Sheet steel cut to a specified width without any bends. Typically used for bracing and transferring loads by tension.

Floor Joist: A horizontal structural framing member that supports floor loads.

Header: A horizontal built-up structural-framing member used for floor openings to transfer loads to adjacent framing members.

In-Line Framing: Framing method where all vertical and horizontal load carrying members are aligned when required to properly transfer loads.

Lip: The part of a C-Shape that extends from the flange at the open end. The lip increases the strength characteristics of the member and acts as a stiffener to the flange.

Loads, Live and Dead: Dead loads are the weight of the walls, partitions, framing, floors, ceilings, roofs, and all other permanent construction entering into and becoming a part of a building. Live loads are transient and sustained loads usually created by people and furnishing, respectively.

Material Properties (steel): The chemical, mechanical, and physical properties of steel before or after the cold-forming process.

Material Thickness (steel): The base metal thickness excluding any protective coatings. Thickness is expressed in mils (1/1000 of an inch).

Metallic Coated Steel: Steel that has a metallic coating for protection against corrosion. The level of protection provided is measured by the weight of the metallic coating applied to the surface area of the steel. Typical metallic coatings are galvanizing, galvalume, or galfan which are zinc based.

Mil: A unit of measurement used in measuring the thickness of thin steel elements. One mil equals 1/1000 of an inch (e.g. 33 mil = 0.033 inch).

Multiple Span: The span made by a continuous member having intermediate supports.

Punchout: A hole or opening in the web of a steel-framing member allowing for the installation of plumbing, electrical, and other utility installation. A punchout may be made during the manufacturing process or in the field with a hand punch, hole saw, or other suitable tool.

Seismic Zone: Seismic Zones designate areas with varying degrees of seismic risk and associated seismic design parameters (i.e., effective peak ground acceleration). Seismic Zones 1, 2, 3, and 4 correspond to effective peak ground acceleration of 0.1g, 0.2g, 0.3g, and 0.4g, respectively (1g is the acceleration of the earth's gravity at sea level).

Single Span: The span made by one continuous structural member without any intermediate supports.

Span: The clear horizontal distance between bearing supports.

Structural Sheathing: The covering (e.g., plywood or oriented strand board) used directly over structural members (e.g., joists) to distribute loads, provide lateral stability to the framing members, and generally strengthen the assembly.

Stud: Vertical structural element of a wall assembly that supports vertical loads and/or transfers lateral loads.

Track: Used for applications, such as band or rim joists, for flooring systems. A track has a web and two flanges, but no lips. Track web depth measurements are taken to the inside of the flanges. Refer to the figure below.

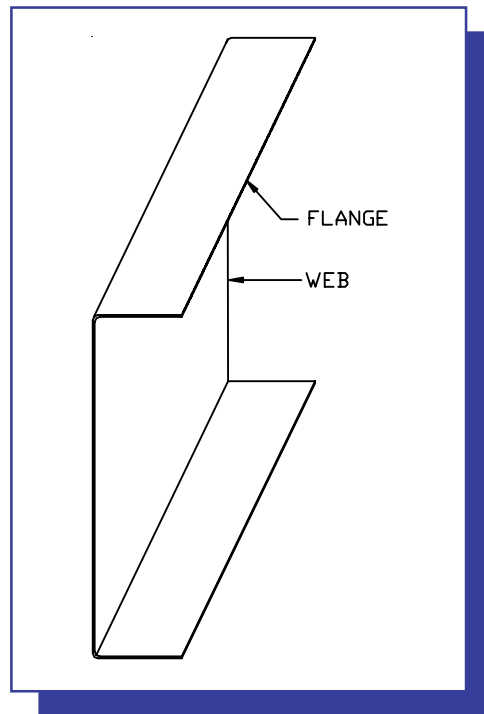

Web: The part of a C-Shape or track that connects the two flanges.

Web Crippling: The localized permanent (inelastic) deformation of the web member subjected to concentrated load or reaction at bearing supports.

Web Opening: See “Punchout”.

Web Perforation: See “Punchout”.

Web Stiffener: Additional material that is attached to the web to strengthen the member against web crippling. Also called a bearing or transverse stiffener.

Wind Exposure: Wind exposure is determined by site conditions that affect the actual wind speeds experienced at a given site. For the purpose of this document, Exposures A/B represents urban, suburban, or wooded terrain. Exposure C represents open terrain with scattered obstructions.

Wind Speed: Wind speed is the design wind speed related to winds that are expected to be exceeded once every 50 years on average at a given site (i.e. 50 year-return period). Wind speeds in this document are given in units of miles per hour (mph) by “fastest-mile” measurements.

Yield Strength: A characteristic of the basic strength of the steel material. It is the highest unit stress that the material can endure before permanent deformation occurs.

U.S. Department of Housing and Urban Development
HUD User
P.O. Box 6091
Rockville, MD 20849

Official Business
Penalty for Private Use \$300
Return Service Requested

FIRST-CLASS MAIL
POSTAGE & FEES PAID
HUD
PERMIT NO. G-795