





Explanation

This module provides strategies for including energy efficiency in the process of converting attics, basements, or garages to finished space.



Space Conversions Objectives

- Identify typical “trouble spots”
- Learn about materials, products, and construction techniques
- Use software to estimate energy savings



2

Key Concepts

Objectives:

1. Identify typical “trouble spots” on some common space conversion projects
2. Learn about materials, products, and construction techniques to remedy these areas
3. Review software tools that model energy use of existing homes and estimate savings associated with remodeling projects

Explanation

Very often, the most practical and cost effective way to add living space is to convert an existing unconditioned space to a finished, conditioned space. Typical areas are attics, basements, garages, and bonus rooms. Although these renovation projects have many things in common with respect to energy considerations, there are some key areas that stand out for each case. This module will help identify typical problem areas and show you some of the most effective options for handling such problems to ensure maximum energy performance.

Action Items

•Consider previous projects you have completed that have involved converting attic, basement, or garage to living space.

1. Are the issues cited in this module familiar? How did you handle these areas?



Space Conversions Opportunities for Efficiency

- Good way to add living space without the complexity of an addition
- Can present challenges with existing conditions
- Can dramatically affect how the house performs as a system



3

Key Concepts

Explore opportunities and challenges related to energy efficiency when converting existing space to living space.

Explanation

When converting existing unconditioned space to living area, there is ample opportunity for improving efficiency and comfort throughout the home. For example, even though the conditioned area may become larger, the new exterior walls and ceiling may be better insulated, hence creating an overall decrease in energy use.

However, this type of project often presents challenges for the remodeler—especially at transitions in framing that can be difficult to insulate and air seal. These projects also present other challenges. For instance, what is the best method for insulating a basement or garage floor slab? Is the expense of insulating worth the savings and/or comfort achieved? As discussed in the earlier House As A System module, space conversions can impact the ability of existing mechanical systems to perform their job adequately. By considering these challenges when planning the project, you can help create a home that performs well after the remodel.

Action Items

When converting unconditioned space to living area, consider how changes will affect the house as a system. Try to improve the entire home's performance through the remodel.

Space Conversions Overview

- Attic/bonus rooms
- Basement
- Garage



Key Concepts

Describe types of space conversions that will be covered in this module.

Explanation

Conversion of existing, non-conditioned space into living area can be an economical and efficient means of adding living space without changing a home's footprint. However, unique challenges can be present when converting existing spaces. Three types of space conversions are most common and are covered in this module: attic, basement, and garages. Although each type of conversion has common issues such as insulating and air sealing, providing heating, cooling, ventilation, lighting, and (sometimes) hot water, each type of conversion has unique aspects that will be the focus of this module. Refer to other modules for general information on insulation, air sealing, windows, and HVAC in remodeling.

This module covers the basics of energy efficiency with respect to remodeling. As with any project, you need to first determine if the structural and code requirements are met before continuing the project (e.g., are the ceiling joists adequate for handling the new live and dead loads in the attic? Do structural posts need to be eliminated or incorporated into the design?)

Action Items

Identify the benefits and drawbacks of space conversion. Are there building code issues with the particular space conversion such as egress from below grade living space? Are there structural issues such as the adequacy of the floor framing system?

Space Conversions

General Efficiency Issues

- Insulation
- Air sealing
- HVAC
- Windows
- Lighting
- Appliances



Key Concepts

Identify general energy efficiency measures that usually apply to all space conversion projects.

Explanation

The overarching principles of creating an efficient and comfortable space apply to space conversions as well as all other remodeling projects. It is important to incorporate energy efficiency into space conversions so that the new space is comfortable and adequately heated and cooled, in addition to being economical to operate. Implementing efficiency measures could eliminate the need for adding heating or cooling capacity, thereby reducing the first cost of the remodel.

Listed on the slide are the elements of a remodel that affect energy efficiency. Insulation is the blanket that helps keep the house warm; air sealing keeps out drafts; HVAC systems (layout, ducts, and equipment) have varying levels of efficiency; windows can be selected for their energy efficiency properties: selection is climate and situation-specific; efficient windows can let in daylight (minimizing artificial lighting needs) but can also be selected and located to allow or to mitigate solar heat gain; new appliances are generally more efficient than older appliances, and ENERGY STAR models of new appliances can take efficiency a step further.

Action Items

When remodeling, be aware of the elements of the project that affect energy efficiency, comfort, and home performance.

Resources



Tools for Analyzing Energy Efficiency Options

- Rehab Advisor – <http://rehabadvisor.pathnet.org>
- Home Energy Saver – <http://hes.lbl.gov/hes/vh.shtml>
- Home Energy Advisor – <http://advisor.lbl.gov/hit/Controller>
- REM/Design – <http://www.archenergy.com/products/rem/>
- TREAT – <http://www.TREATsoftware.com>



6

Key Concepts

Computer software tools can help you analyze the various options available in a remodeling project.

Explanation

These software tools were described in earlier modules. For space conversions and room additions in which the area of the living space may be significantly increased, these tools can be especially useful for analyzing energy loads and identifying the most cost effective upgrades.

Action Items

Use software tools to help guide decisions about energy improvements.

Resources

Rehab Advisor – <http://rehabadvisor.pathnet.org>

Home Energy Saver – <http://hes.lbl.gov/hes/vh.shtml>

Home Energy Advisor – <http://advisor.lbl.gov/hit/Controller>

Rem Design – <http://www.archenergy.com/products/rem/>

TREAT – <http://www.TREATsoftware.com>

Instructor's Note: If the instructor has either REM/Design, TREAT, or other modeling software, a detailed



Attic Finishing Special Issues

- Air pressure/air leakage pathways
- Insulation/thermal boundary
- Solar heat gain
- Mechanical systems
- Windows/lighting



7

Key Concepts

Understand energy efficiency issues particularly applicable to attic conversions.

Explanation

There are several issues that should be the focus of energy efficiency in an attic renovation. Those issues include air pressure and air leakage pathways, selecting the location of insulation, providing space heating and cooling, and lighting.

Because heat rises, the attic is usually at a high pressure with respect to the outdoors, and therefore highly susceptible to air leakage. It is important to be aware of the typical areas that may require additional attention. Often insulation will be added or moved to create the new living space. The placement of insulation defines the “thermal boundary” of the house. This will be discussed more in upcoming slides.

Dark-colored roofs exposed to the sun tend to absorb a lot of energy, which can be conducted indoors. When re-roofing in a hot climate, consider using infrared reflective (IR) roofing material to create a “cool roof.”

Heating and cooling capacity may need to be increased when finishing an attic. Be sure to determine HVAC needs and address them carefully—the whole house can be affected by the changes.

Windows and lighting are often added when finishing an attic. Dormers and skylights are popular options for natural lighting which have special energy considerations discussed later.

Action Items

Be aware of energy issues unique to attic space conversion.

Resources

No-Regrets Remodeling, 1997, Home Energy Magazine, Berkeley, CA.

Fisette, Paul, 1997, “Preventing Ice Dams,”

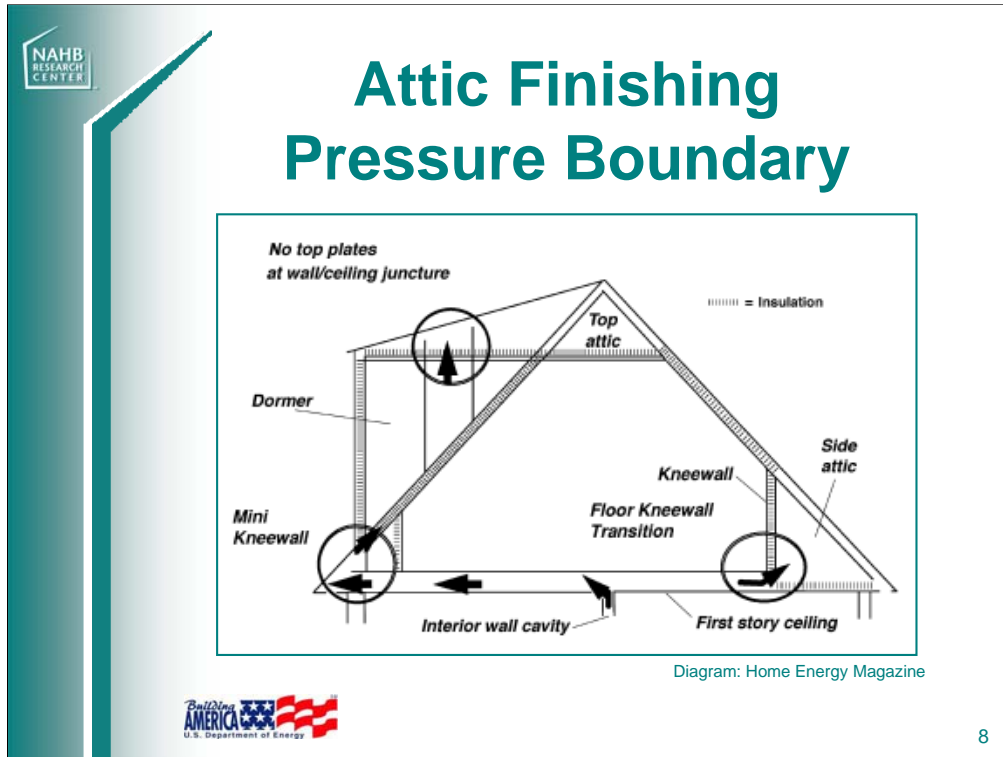

Key Concepts

Understand air pressure differences in homes.

Explanation

Because attics are at the top of a house and hot air rises (called the chimney or stack effect), the attic is usually at a higher pressure than the rest of the house. This higher pressure creates a situation in which air is driven out of the house. Therefore, air sealing becomes extremely important in attic finishing work.

Framing dormers and exposing framing during a remodel provides a good opportunity to seal key framing junctures (places where there is a transition in framing). For example, the floor joist cavity below a kneewall and the top of gable-end open wall cavities can be sealed with rigid foam and caulk or, in the case of wall cavities, with a top plate. Any cavities or chases greater than eight feet in height need to have fire blocking.

Action Items

Resources

Jim Fitzgerald, Robert Nevitt, and Michael Blasnik, "User-Friendly Pressure Diagnostics," Home Energy Magazine, September 1994, <http://homeenergy.org/archive/hem.dis.anl.gov/eehem/94/940908.html>

David Connelly Legg, "Beauty and the Beast Upstairs," Home Energy Magazine, March 1995,

Attic Finishing

Selecting the Thermal Boundary

- Kneewalls (side attics)
- Dormers
- Flat ceilings (top attics)
- Cathedral ceilings (sloped ceiling)

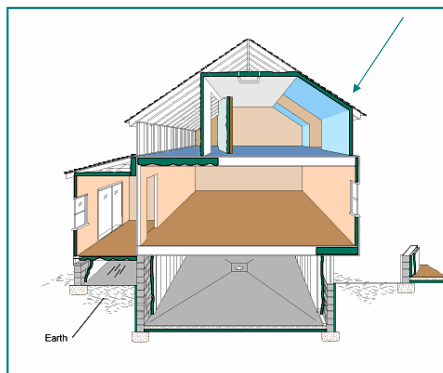

Key Concepts

Selecting and insulating/air sealing the thermal boundary.

Explanation

When finishing an attic, the area that will be insulated and air sealed is called the thermal boundary. The dark green areas in the diagram represents the thermal boundary of the house. The remodeler and owner will determine where the thermal boundary will be located—for example, kneewalls can be insulated, or the insulation can be placed at the roof rafters—leaving the area behind the kneewall in the conditioned space. There is an advantage to including an area in the thermal boundary when ductwork or mechanical systems are located within that area. The disadvantage of including an area within the thermal boundary is that additional volume needs to be conditioned.

Action Items

Understand the issues associated with creating a thermal boundary for an attic space.

Identify the location of the thermal boundary that optimizes the insulation and air sealing of the house as well as the homeowners' preferences (e.g., will attic storage areas be within or outside the thermal boundary).

Pay special attention to air sealing problem areas.

Resources

NAHB RESEARCH CENTER

Common Attic Air Leakage Pathways

Diagram: VA Home Energy Savers Handbook

Building AMERICA U.S. Department of Energy

10

Key Concepts

Be able to identify common areas prone to air leakage into the attic.

Explanation

The areas depicted in the diagram, in addition to dormers and other areas mentioned previously, are prone to air leakage.

Action Items

The diagram above shows common places of air leakage in attics. When finishing an attic space, some of these areas are likely to be enclosed (such as a chimney or a plumbing stack). Be sure to seal these areas before framing around them or concealing them—air leakage will not be prevented just because leakage areas are no longer visible. Special materials will be needed around a chimney—such as metal flashing and high temperature caulk—but spray foam can be used in most other areas. Keep a few cans of foam sealant on the truck, ready for quick air sealing when it's needed. If foam and caulk are readily available on the job, it is more likely that air sealing will be done. Foam sealing is a quick and simple task that can save lots of energy, prevent moisture problems, and create satisfied customers. Great Stuff, DAP, and Hilti are three brand names of foam sealant carried at building supply stores. DAP can be cleaned up with water, and Hilti claims its canisters are reusable.

Resources

Air Sealing Attic Penetrations

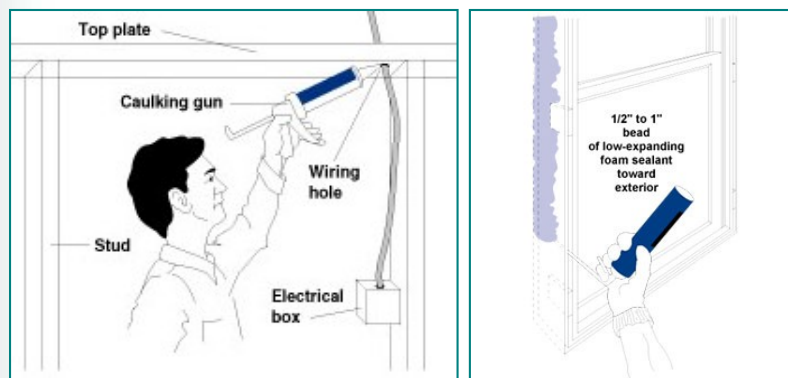

Diagram: VA Home Energy Savers Handbook



Key Concepts

Learn the most effective methods and materials for air sealing in an attic conversion.

Explanation

When finishing an attic, many of the locations to air seal are the same as those in other parts of the house – around windows, wiring or plumbing penetrations in building cavities adjacent to unconditioned space or the exterior, and framing junctures such as intersecting walls or exterior corners. For sealing around windows, there are newer, low-expansion foams which do not cause windows to bind.

Action Items

Resources

Air Sealing at Kneewall

- Seal at kneewall
 - Use rigid foam, wood blocking, and caulk or foam
 - Make sure openings are tight



Key Concepts

Creating an effective thermal/air boundary at kneewalls.

Explanation

Kneewalls: One of the leakiest areas in a home can be the floor/kneewall connection. To find air leakage sites, you can try looking for dirty insulation that is a sign of air flowing through it (the insulation acts like an air filter, not an air barrier). Even when insulated, heated air can escape through the floor cavity beyond the insulated kneewall into the uninsulated side attic. This kneewall/floor area represents a large opening which, because of its location at the top of the house (and hence high pressure difference due to the stack effect) can force a lot of conditioned air out of the house. If left unsealed, this area becomes a strong driving force for energy loss—especially in the winter. The tendency for warmer air to rise and move from an area of higher to lower pressure will result in considerable heat loss. Even in the summer, such an area left unsealed can be a source of infiltration of hotter outdoor air. If you choose to place the thermal boundary at the kneewall, the area between the kneewall and floor joist should be sealed to prevent air leakage. Fiberglass insulation alone will not do the job. Sealing can be accomplished by:

1. Cutting rigid foam or plywood blocking to fit in the floor joist cavity just below the kneewall. Seal around plywood or rigid foam with caulk or spray foam.
2. Use dense-pack cellulose throughout the side attic to seal and insulate entire joist area. Typically, the sidewall attic is atop first floor conditioned space. It is a good time to increase the attic insulation here as well as in

Air Sealing at Kneewall



Key Concepts

Explanation

Photo left: back side of insulated wall when viewed from unconditioned attic. Notice beginnings of discoloration at bottom of batts due to air movement through the batts.

Photo right: lack of air barrier here results in unconditioned attic's connection to interior spaces of house (under tub, space between floors via hole at tub drain, recessed lights in ceiling of level below).

Action Items

Resources

Attic Finishing Cathedral Ceilings

- Advantages:
 - Can save energy
 - May be simpler to execute
- Disadvantage:
 - Air barrier may be difficult to install

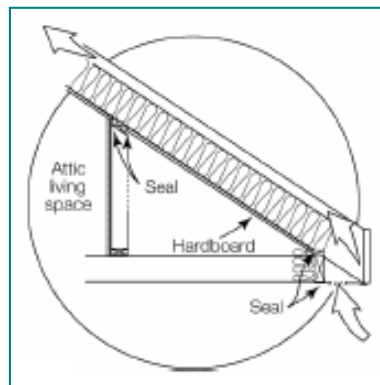

From DOE Technology Fact Sheet
– www.southface.org



Key Concepts

Be aware of advantages and disadvantages of moving the thermal boundary to roofline.

Explanation

An alternative to sealing kneewalls is to simply insulate at the roofline—thereby moving the thermal boundary outward and making the side and top attic part of the home's conditioned space. To do this, the roof slope and the gable end wall will need to be sealed and insulated. This approach may be easier than trying to insulate and seal under kneewalls, and it can save energy if there is ductwork in the side attic.

To seal and insulate the sloped roof above the side attic, create an air space (at least one inch) for ventilation extending from the soffit to the top attic (if top attic is vented) or ridge vent at roof peak (if sloped ceilings extend to top of roof). The airspace can be created with manufactured baffles or one-inch lumber along rafters and vapor permeable fiberboard blocking. A vapor retarder is used in cold and mixed climates on the interior side of the insulation. The air barrier (which can be the vapor retarder or foil-faced foam) needs to extend from the top plate of the kneewall down to the top plate of the first-story wall. Seal all seams with caulk, aluminum tape, Tyvek tape, or other sealant. At the junction with the top wall plate, be sure to seal the floor joist cavities at the eaves

Action Items

Consider bringing the side attic into the thermal boundary by insulating at the

Vented vs. Unvented Roofs

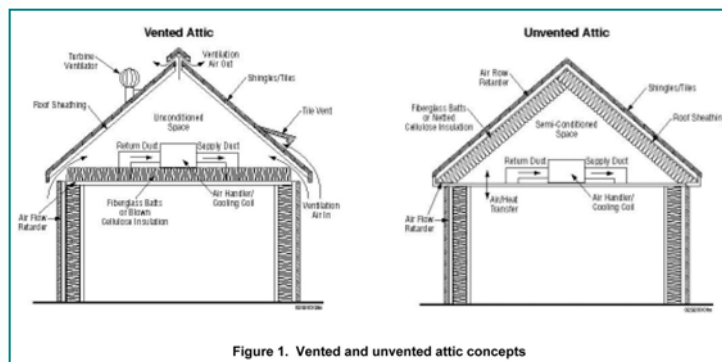

Source: NREL Diagram at <http://www.nrel.gov/docs/fy03osti/32827.pdf>



Key Concepts

Consider unvented roofs

Explanation

A proven alternative to vented attic design is to create an unvented attic. Unvented attics have been demonstrated successfully in hot-humid climates, hot-dry climates, and cold climates. In this system, air sealing and insulation are done at the roofline and no attic airspace for ventilation is created. Advantages include the fact that ductwork and HVAC equipment located in the attic are now brought within the conditioned space and the need to seal the numerous penetrations between living space and attic is reduced. (It is a good idea to seal wiring and plumbing penetrations to the attic anyway.) Note that when unvented attics are used in hot-humid climates with asphalt shingles, current practices recommend placing a vapor barrier between the shingles and roof sheathing. If used in moderate and cold climates, high levels of insulation and air sealing are paramount.

More information about unvented attics can be found at <http://www.buildingscience.com/resources/roofs/>.

Action Items

Check with the local building department to make sure an unvented attic is accepted by code.

Resources

Attic Finishing Dormers

- Base of dormer (or “eyebrow roof”) notorious for air leakage and poor insulation
- Side walls without top plates can also contribute to leakage

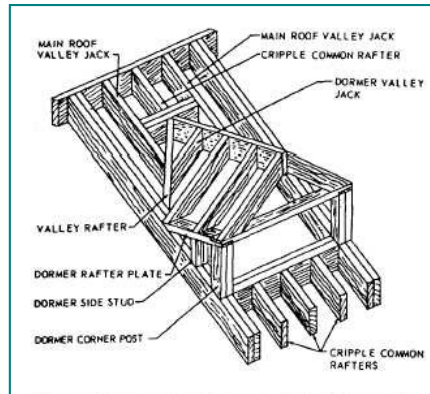

Diagram: www.tpub.com



Key Concepts

Identify key areas to seal when dormers are included in the design.

Explanation

To create light and add floor space, dormers can be added to attics. Dormers have two areas notorious for air leakage: the mini kneewalls (or eyebrow roof area) at the base of the dormer, and where the dormer walls meet the top attic.

If you build the dormer without a top wall plate, use rigid foam and caulk to seal between studs where leaks into the attic may occur.

Action Items

When adding dormers, be sure to insulate and seal areas that might otherwise get overlooked.

Resources

<http://www.ornl.gov/sci/roofs+walls/facts/RetrofitBestPractices/homeenerguide15b1.pdf>

Attic Finishing

Types of Insulation

- Dense-pack cellulose
- Spray foam
- Batt
- Loose fill cellulose and fiberglass
- Rigid foam



Key Concepts

Become familiar with different types of insulation and most effective applications.

Explanation

There are a wide variety of insulation options. What to select will depend on the job, consumer preference, and budget.

Dense pack (wet spray) cellulose and spray foam can fill wall and ceiling cavities. They both have the benefit of providing some resistance to air infiltration in addition to insulating value.

Batt insulation is usually the least expensive insulation material, although installation can cost more than blown products. Batts are typically fitted into ceiling and wall cavities. The most common type is fiberglass, but mineral wool (rockwool) products are also available.

Loose fill insulation is typically blown into flat attic spaces and is not appropriate for wall or ceiling cavities.

Rigid foam can be used to add R-value in tight spaces. It can be one of the best insulating, and highest cost, choices.

Action Items

Be aware of various insulation options and their cost and benefits.

Resources

NAHB RESEARCH CENTER

Ceiling Insulation

- Rulers and attic card in each attic space
- Blown insulation may block soffit vents – use baffles

Building AMERICA U.S. Department of Energy

18

Key Concepts

Ensure a quality insulation job.

Explanation

This slide shows loose fill insulation blown into an attic. In order to get good insulation values from blown insulation, you must keep insulation clear of soffit vents, and measure insulation depth and amount of insulation (number of bags). Manufacturers specify the number of bags and depth of insulation for a given R-value. A ruler at various points in the attic can assure that the full depth of insulation is installed throughout. Baffles shown above provide an air space for ventilation from soffit vents. Blocking or “stops” may be required at the eave to make sure that the soffit vents are not covered with insulation. The card shown in the photograph above is verification by the insulation contractor regarding the depth, R-value, and date of installation of the insulation.

Action Items

Resources

Attic Finishing Radiant Barriers

- Appropriate for hot climate
- Especially when ducts and mechanical equipment in attic
- Need airspace
- Shiny side faces living space



Key Concepts

Understand when radiant barriers are effective.

Explanation

Radiant heat travels through space rather than through an object. An example of radiant heat is the sun's warming effect on an object that is in its path.

Radiant barriers need an airspace in order to work: they will not work if drywall or another surface abuts the radiant barrier. Therefore, they are appropriate for attic finishing in hot climates in top or side attic areas and are not appropriate for cathedral ceiling areas. They are especially helpful at reducing energy consumption if ducts and/or mechanical equipment are located in attic areas.

Action Items

If you live in a hot climate, consider the use of radiant barriers in top and side attics, especially if ducts or mechanical equipment is located within these areas.

Resources

<http://www.toolbase.org>

Understanding and Using Reflective Insulation, Radiant Barriers, and Radiant Control Coatings, by the Reflective Insulation Manufacturer's Association <http://www.rima.net/handbook/index.htm>

Attic Finishing Space Conditioning Ducts

- If adding supply or return duct:
 - Seal and insulate ducts
 - Balance airflow to entire house
- Consider stand-alone system
- Try to locate ducts within conditioned space



Key Concepts

Important considerations regarding conditioning the new living space.

Explanation

When adding ductwork for heating or cooling to a newly finished space, it is imperative that a contractor design the duct system according to industry standards. Ask your contractor to perform ACCA Manual J and Manual D calculations to verify equipment sizing and to size the new ducts. Often, existing equipment will be large enough to handle the new space because most HVAC equipment is over-sized at the outset. If your HVAC contractor resists performing the design calculations, it may be advisable to look for a new contractor who is familiar with these methods. It will not only benefit you on the current project, but on every project you do.

The slide shows ductwork and equipment located within a conditioned, unvented attic. This view is of the front house wall and attic floor facing the front porch, hence the insulation on the floor. Note that the ductwork is insulated even though it is inside the thermal boundary because the HVAC contractor used flex duct, which comes insulated. This helps maintain supply temperatures to the registers.

Action Items

Have the contractor perform a Manual J calculation that includes the new finished space to ensure the existing HVAC system is adequate.

After determining that capacity is adequate, ask the contractor to perform a Manual D duct design to ensure that airflow to the new space will suffice

Attic Finishing Space Conditioning Equipment

- Zoned delivery system

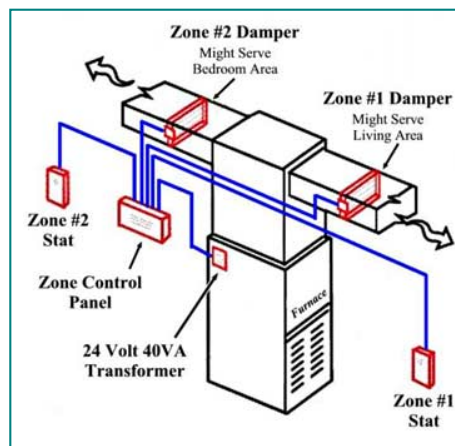

Diagram: Earthtoys.com

Key Concepts

Zoning HVAC systems can contribute to comfort and efficiency.

Explanation

A zoned system refers to a single HVAC system in which heating and cooling is directed to one or more areas of the house as needed—each zone is served by a separate thermostat. When adding ducts or hydronic piping for HVAC systems in a space conversion project, particularly an attic conversion, zoning can save energy and improve comfort. Energy is saved because heating and cooling is provided to the space when it is needed and can improve comfort by allowing occupants to control temperature by a thermostat located in the space. Even in a well-insulated attic conversion, the remodeled space can be warmer than the rest of the house simply because warm air rises. In this case, the ability to control the temperature for finished attic space independently from the rest of the home is important. For zoning a forced air system, motorized dampers and other controls are used to control the amount of heating or cooling to the space. For hydronic systems, multiple pumps and piping loops create individual zones.

Action Items

Resources

Online Zoning and HVAC Controls Tutorial:
<http://www.hometech.com/learn/hvac.html>

Attic Finishing Adding Natural Light

- High performance windows in gable or dormers
- Tubular skylights
- Traditional Skylights

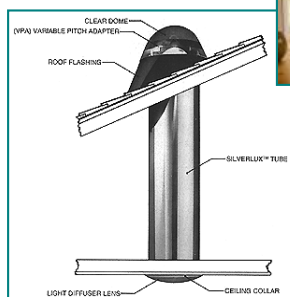

Key Concepts

Identify ways to add light to the new space without compromising comfort and efficiency.

Explanation

High performance windows don't cost much more (about \$25 each) and will improve comfort and energy efficiency. Leaky and poorly insulating windows will be colder in the winter and hotter in the summer than their high performance counterparts. Skylights are often used in finished attics. However, the direct solar gain through a skylight can severely increase energy needs for cooling and can also increase the heating load because the skylight has a much lower insulating value than the ceiling. For example, by locating an R-3 window in the ceiling, you will be displacing R-30 or higher insulation in the ceiling compared to the typical R-13 or R-21 in a wall. For energy efficiency purposes, steer the client towards windows in the gable ends of the space or to dormers and clerestory windows for sloped ceilings. (Don't forget to air seal around the rough openings.) Tubular skylights also may be an energy efficient alternative to traditional skylights. They have a higher R-value and admit diffuse radiation rather than direct sunlight. Therefore, they contribute less to heat gain in summer and heat loss in winter. If the customer has their heart set on skylights, encourage them to install thermal shades or shutters. Shades, preferably thermal shades, can reduce energy loss and unwanted glare.

Action Items

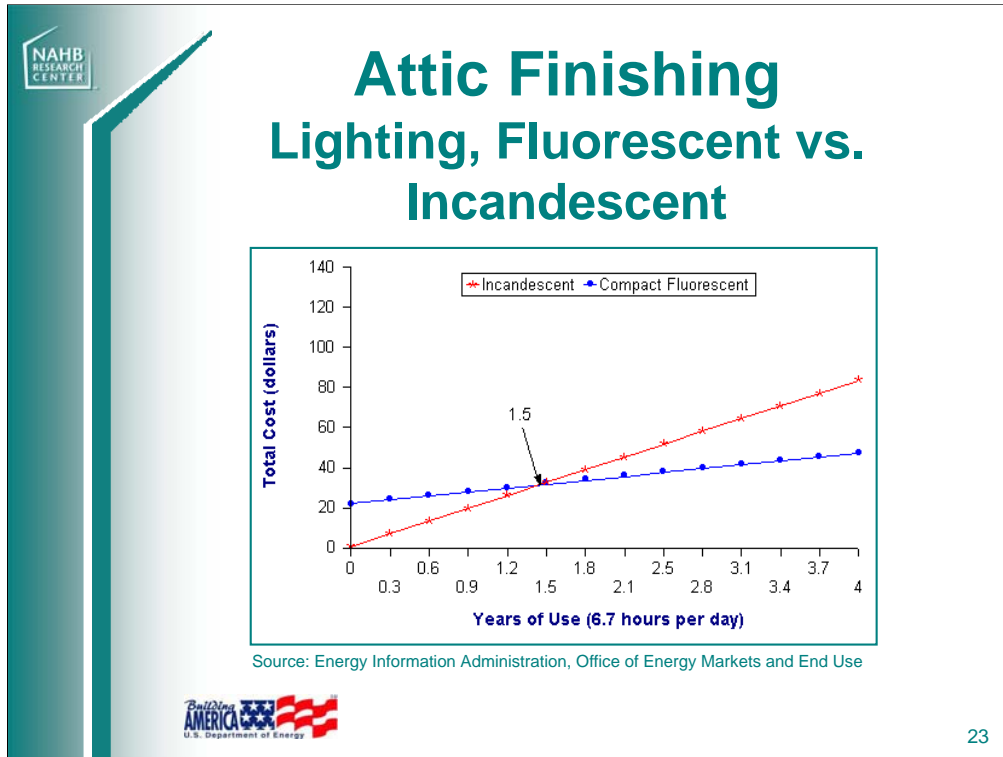

Key Concepts

Become aware of the advantages of fluorescent lighting.

Explanation

Electric lighting choices for finished attics include recessed lights, incandescent wall or ceiling fixtures, or switched receptacles and lamps. Fluorescent options are available in all fixture types. Not only does incandescent lighting use more energy to produce the same amount of light as fluorescent lighting does, it also adds heat to a space. Since heat rises, attics are usually the hottest rooms in the house, so adding heat can be detrimental to energy consumption and comfort.

Permanent fluorescent fixtures take only 2- or 4-pin bulbs. Compact fluorescent lamps (CFLs), on the other hand, fit into conventional screw-in fixtures. For permanent fluorescent fixtures, the replacement cost for bulbs is lower than screw-in fluorescent bulbs, and the bulbs cannot be replaced by incandescent bulbs. However, pin-type bulbs may be difficult to find in some areas.

The slide compares the cost of incandescent bulbs and fluorescent. Incandescents are less expensive to purchase. However, they use more electricity and thus, cost more to operate. Assuming lights are on for 6.7 hours per day, fluorescent bulbs will begin paying for themselves after one and a half years because they last longer in addition to being more energy efficient. After about four years, the fluorescent bulb will cost the homeowner about half as much as the incandescent.



Lighting Options









24

Key Concepts

Become aware of lighting choices for finished attics

Explanation

There are many fixtures available that can accommodate fluorescent lamps. Table lamps can accommodate compact fluorescent bulbs. Often, finished attic space serves as a bedroom. If a switched receptacle will be used (for code compliance or other reasons), select a receptacle that is not near the bed. Usually, it is inconvenient to have the bedside lighting for reading also be the ambient lighting that is switched upon entering the room.

All light boxes that penetrate the exterior envelope (wall or ceiling) should be caulked around the perimeter after the finish surface is installed. In a cathedral ceiling, insulation value will be compromised above light fixtures because of the electrical box in the ceiling. When using recessed fixtures, choose those rated for contact with insulation (IC rated) and consider using a high-R rigid foam above (or behind) the housing.

Electrical boxes can also be a source for air leakage. Airtight electrical boxes for receptacles and switches are available from various retailers and manufacturers.

Action Items

Consider options for natural light to reduce need for artificial lighting.

If using recessed lighting in finished attics, use airtight junction boxes and IC-rated recessed can lighting.

Resources

Fisette, Paul, "Roofing and Siding Rehabs Get an Energy Fix," Home Energy Magazine, November, 1996, <http://hem.dis.anl.gov/eehem/96/961110.html#96111020>

AirFoil, Inc., manufacturers of airtight junction boxes <http://www.airfoilinc.com>

Basement Finishing Special Issues

- Locating the thermal boundary (combination crawl and basement)
- Moisture
- Radon
- Insulating walls and floor
- HVAC
- Lighting



Key Concepts

Understand particular concerns related to finishing basements.

Explanation

Insulating the basement is an effective method for reducing the energy consumption of the renovated space. However, there are some special considerations before undertaking a basement renovation.

The first question is whether there are any existing signs of moisture problems. If there are visible signs of moisture, it may be wise to reconsider finishing the basement at all. While some dampness may be tolerable in an unfinished basement, enclosing walls or installing carpet on a damp basement slab may exacerbate the problem in addition to compromising the newly installed materials. While measures should be taken to repair a severe moisture problem regardless of the basement finishing project, the level of difficulty and expense of foundation drainage repair increases if the area is to become living space.

Even if moisture is not visible, care must be taken when insulating basement walls and floors to control moisture. Concrete wicks moisture from the ground and is likely to be damp even if it doesn't look wet.

A homeowner should also test for radon before creating living space in the basement. Test kits are available for less than \$10 and are simple to perform. If radon is a problem in the home, remediation options are available. Radon can enter a home through cracks in basement floors and sump pumps; seal these areas to prevent radon entry.

Special concerns with HVAC systems in basements include dehumidification

Basement Finishing Moisture Issues

- Existing moisture problems?
- Land graded away from the foundation?
- Foundation cracks?
- Gutters work properly & divert water away?
- Does the house have overhangs?



Key Concepts

Identify typical sources of moisture in basements.

Explanation

When undertaking a basement renovation project, careful planning is needed to avoid future moisture problems. If there are any existing moisture problems, the best idea might be not to renovate the basement at all. However, if there is a basement water problem, the following can help: 1) Land should be graded away from the foundation 2) Foundation cracks should be fixed. 3) Gutters should be cleaned and extended several feet from the foundation. 4) Overhangs can help divert water from the foundation.

Action Items

Carefully examine existing conditions for potential future moisture problems. Before undertaking a basement finishing project, look at existing conditions.

Resources

National Association of Waterproofing and Structural Repair Contractor's Association website (<http://www.nawsrc.org>) offers good information about basement moisture problems and how to prevent or repair them or find a contractor who can.

NAHB
RESEARCH
CENTER

Basement Finishing Insulation & Moisture



Building
AMERICA
U.S. Department of Energy

27

Key Concepts

Moisture considerations when developing insulation and framing method.

Explanation

Insulating existing basements from the interior presents a unique challenge. Moisture can come from liquid water through a masonry wall that is in constant contact with the ground, capillary action from moisture-absorbing materials in contact with damp walls and floor, and vapor diffusion from inside and outside. Conventionally, especially in cold climates, basements were insulated from the interior and a vapor barrier placed on interior side of the wall. However, research has shown that this practice can lead to trapping of moisture in the wall cavity which can cause mold and decay. Insulated basement walls must be able to dry to the interior.

Do not put fiberglass batts or cellulose against a masonry wall. These materials will absorb moisture if the wall becomes damp. Use a rigid insulation against the wall or drape the wall with a vapor retarder that will provide a capillary break, such as 15# felt paper, Tyvek, or building paper. Poly in this location has been shown to trap moisture in some locations and is not recommended in the wall assembly.

Action Items

Control airflow into the wall cavity and towards masonry wall by air sealing. Install a sealed air barrier (but not a vapor barrier) on the interior of the insulation to avoid possible condensation.

Do not use a vapor barrier on the inside of a wall cavity. This includes

Basement Finishing Wall Insulation

*Note: ceiling
insulation is for
sound proofing only*

**Building America
recommends:**

- **EPS or XPS
rigid foam
before framing**



Key Concepts

Effective basement wall insulation systems will avoid moisture problems and enhance energy performance.

Explanation

The latest recommendation for basement finishing is based on years of research and diagnosing wall system failures by Building Science Corporation. The physics of moisture flow in a basement are simple: the ground around the basement is usually damp, so drying is not likely to occur to the outdoors. Therefore, drying of the wall system, in case it gets wet, must occur to the indoors. The system now advocated by the Building America program uses rigid foam insulation as a capillary break to separate the wood framing and other moisture-sensitive materials from the often-moist concrete walls and floor.

Note that only certain adhesives are compatible with the foam—such as Liquid Nails LN-604.

If two layers of foam are going to be used, the foam does not glue to itself easily. So, try gluing the first layer to the foundation wall and the second layer to the stud wall before standing the wall up.

Extruded or expanded polystyrene is the material of choice. Avoid foil-faced rigid foam which will prevent drying to the interior.

Note also that, to meet fire code, all areas having foam will need drywall, even unfinished areas. Tape seams and try to stagger seams as well.

Action Items

When finishing a basement, keep moisture sensitive materials (e.g., fiberglass batt insulation, drywall, wood) away from the ever-damp concrete walls and floor. Install a layer of rigid foam insulation against the masonry wall to serve as a capillary break. When installing, it is important that the foam make contact with the foundation wall as fully as possible and that seams and the perimeter be caulked with a sealant.

Resources

http://www.buildingscience.com/resources/foundations/renovating_your_basement.pdf

<http://www.buildingamerica.gov>

Basement Finishing Seal and Insulate Rim Joist

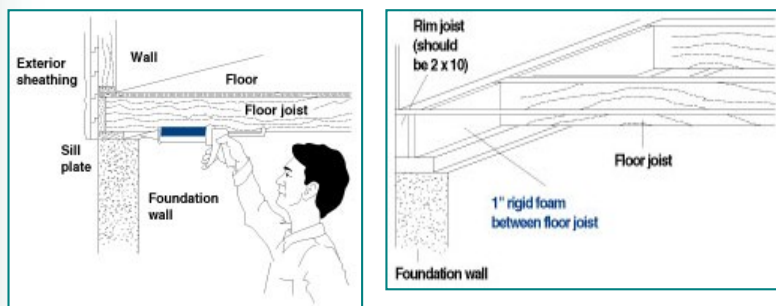

Photos: VA Home Energy Savers Handbook



Key Concepts

Understand how to insulate and seal rim joist area effectively.

Explanation

Before framing walls for the basement is an excellent time to seal and insulate the rim joist area and sill plate. Use caulk or foam sealant where the sill plate meets the foundation to prevent air leakage—this is an important area to seal because the chimney or stack effect creates low pressure in the basement (relative to outside), thereby drawing outdoor air into the lower portions of the house. A variety of insulation options are available including rigid foams, spray foams, wet-blown cellulose, and fiberglass. Although more time consuming, in severe climates, the best practice is to caulk at the joint between the band joist and the sill plate before insulating the cavity.

Action Items

Be sure to seal and insulate the rim joist area including the sill plate/foundation connection while it is accessible.

Resources

Basement Finishing Insulating Floors

- 55°F slab is uncomfortable on most feet
- Raise floor temperature by insulating the slab
- Check for headroom when planning



Key Concepts

Basement floor insulation is necessary to provide comfort and a room that is easy to heat.

Explanation

Concrete basements tend to be close to the temperature of the ground, year-round. Insulating the floor can prevent moisture problems at the concrete slab and can improve comfort for the homeowners. To insulate basement floors, you can do one of the following:

1. Place sheets of extruded polystyrene—joints taped with Tyvek tape or similar—directly on the floor with “nailers” for attaching the subfloor. “Nailers” for the subfloor can be screwed to the concrete floor through the insulation. This method provides a continuous R-value across the entire floor.
2. If headroom is tight, screw “nailers” directly to the concrete slab and place rigid insulation between. Use a material such as foam sill sealer or 15# felt paper underneath the nailers to serve as a capillary break.

Action Items

Keep basement floors warm and comfortable by insulating them.

Resources

Yost, N., and J. Lstiburek, 2002, Basement Insulation Systems, http://www.eere.energy.gov/buildings/building_america/pdfs/dh/35017.pdf

Basement Finishing Preventing Radon Entry

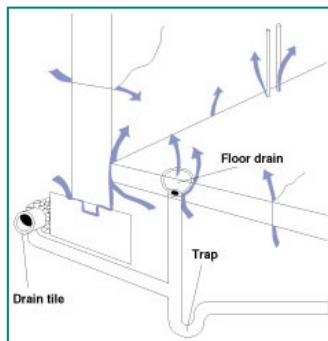

Typical entry points for radon

Diagram: VA Home Energy Savers Handbook

Key Concepts

Understand practical, effective methods of radon mitigation.

Explanation

If there is an elevated level of radon in the basement, there are several relatively simple and inexpensive methods to mitigate that should be done before finishing the space. This is especially important because, with the efficient renovation, you are now making the space less naturally ventilated (less drafty). Reduced air leakage means that the radon gas may reach higher concentrations. Sealing all penetrations and cracks in the slab and walls is the first step. This includes sealing around the perimeter where the slab meets the walls. If there is a sump pump in another area of the basement that will remain unfinished, a sealed cover should be installed. A well-sealed air barrier should also be installed on the floor and the interior of the walls – as is done for energy efficiency reasons. A fan can also be installed in the basement to pressurize the space and inhibit the entry of soil gas.

In new construction, the usual means of reducing or eliminating a radon problem is called Active Subslab Suction, in which a pipe(s) is inserted under the slab and connected to an exterior fan which draws air from under the slab and away from the house. The negative subslab pressure prevents soil gas from coming into the basement area. This is not likely to be a cost-effective or practical measure for existing basements. Unless there is a good layer of stone or gravel beneath the slab, it will be difficult to de-pressurize throughout.

Other radon reduction methods are discussed in EPA's Consumer's Guide to

Basement Finishing HVAC

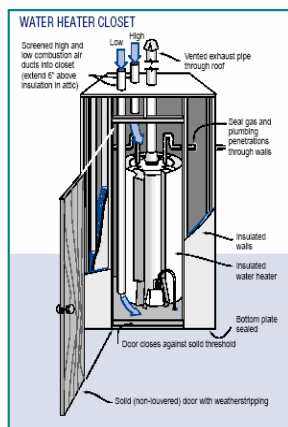

- Dehumidification
- Supply and return
- Combustion equipment air intake



Key Concepts

Understand HVAC issues that are of particular importance in finished basements.

Explanation

Below-grade basements often require dehumidification. To provide dehumidification, a stand-alone or ducted dehumidifier can be used. Dehumidifiers tend to use a lot of energy—there are ENERGY STAR models available which will use less energy than their non-labeled counterparts. Because humidity can be a problem in below grade areas, even in the winter, air conditioning units alone are often not sufficient to provide dehumidification. Furthermore, basements usually remain fairly cool in the summer and air conditioning may not even be needed to keep these areas cool.

If supply and return ductwork are to be added or extended to the finished basement area, it is advisable to check the size of existing equipment relative to the new building energy loads, properly size new ductwork, and re-balance the entire system. As with the attic renovation, it may be a good idea to make this room its own zone so that it does not depend upon thermostats on upper floors.

When combustion equipment is located in the basement, be sure that basement finishing will not affect the supply of intake air for the equipment. Inadequate make-up air for combustion equipment can lead to backdrafting—a potentially dangerous situation in which the byproducts of combustion are drawn into the living area. If the existing equipment is going to be replaced, it is a good idea to install never-vented or sealed combustion

NAHB
RESEARCH
CENTER

Basement Finishing Lighting

- Artificial lighting usually necessary
- Good fluorescent options available



Buildings
AMERICA
U.S. Department of Energy

33

Key Concepts

Review lighting options and highlight any differences with respect to basements.

Explanation

Since below-grade basements often lack adequate natural lighting, artificial lighting is usually necessary. As discussed in earlier modules and in previous sections of this module, there are numerous energy efficient options that can provide warm white light. Permanent fluorescent fixtures accept the pin-type of fluorescent lamp only. Other conventional screw-type fixtures can accommodate compact fluorescent lamps.

As long as the band joist is adequately sealed and insulated, using can lights in a basement should not compromise energy efficiency, like it can in attics and top floors.

Air leakage is not as much of an issue with basement finishing as it is with attic finishing, since conditioned space is overhead and the majority of wall area is usually below grade. However, if the band joist is not properly sealed and insulated, air leakage from the basement can result in energy losses at the perimeter. In some instances, insulation may be used in the basement ceiling for soundproofing. If this is the case, be sure to use insulation contact (IC) rated recessed lights that can be installed in contact with the insulation.

Action Items

Garage Finishing



Photos: Courtesy of Curb Appeal Renovations



Key Concepts

Identify issues that may be of particular importance when finishing existing garage space.

Explanation

Most of the energy-efficiency related aspects of finishing a garage are covered under attic and basement conversions or room additions. However, some unique issues will be covered over the next few slides.

Action Items

Resources



Garage Finishing Foundation and Floor

- If you need to dig to prove footings to an inspector, consider adding foam insulation to exterior (if allowed by code)
- Consider building a platform
- Can use basement techniques for floor insulation
- Be sure to seal bottom plates



35

Key Concepts

Possible solutions for insulating garage foundations and floors.

Explanation

Some inspectors may require excavation to prove the foundation system is adequate for the converted living space. If this is the case, you may want to add exterior insulation at the same time.

Some contractors have built the finished floor on a platform on top of the garage slab—creating an area for insulation and bringing the floor height to the level of the existing house. This helps tie the new room architecturally into the house and simplifies the floor insulation detailing. A vapor retarder such as 15# felt paper should be used under the platform in most cases.

The same floor insulating system used for basements—typically a configuration of rigid foam and nailers or “sleepers” to attach the finished floor—can also be used for garages. The difference here is that the existing concrete slab of a garage is usually at ground level. Therefore, R-value is of greater concern. A foam board with a high R-value per inch is often the best solution to meet demands for insulating value and moisture considerations. Headroom is usually not an issue with garages—which often have 10 foot or higher ceilings.

Action Items

Resources

NAHB RESEARCH CENTER

Slab-on-Grade Insulation

Slabs lose heat at the edge!

Building AMERICA U.S. Department of Energy

36

Key Concepts

Learn how to effectively insulate the garage slab.

Explanation

Energy loss through a slab edge can be seen as bright spots in the upper right photo. This infrared black and white photo shows how heat is lost both under the sill plate (see bright spots) and along the slab edge through conduction (the grey line below the wall).

Details for adding insulation to a slab edge are shown in the section (next slide). While this is for a newly constructed slab, adding insulation to an existing slab should be done in a similar manner – especially in cold and mixed climates.

While digging and backfilling this area, make sure grade is at least 8” below any wood framing and is sloped away from the building. The recommendation in Durability By Design written by the NAHB Research Center is that the grade be sloped at least ½-inch per foot to a distance of six feet from the building.

Action Items

Resources

Slab-on-Grade Insulation

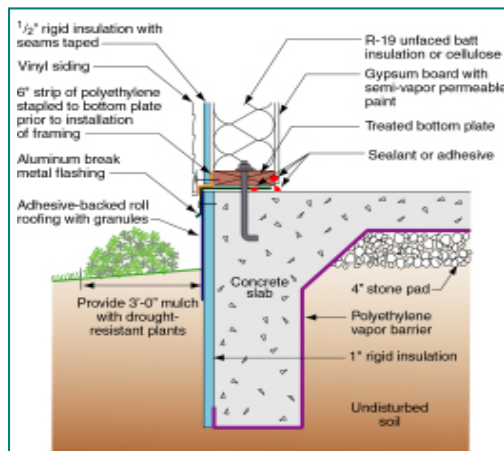

Slab-on-grade insulation detail

Key Concepts

Learn how to effectively insulate the garage slab.

Explanation

Details for adding insulation to a slab edge are shown in the section. While this is for a newly constructed slab, adding insulation to an existing slab could be done in a similar manner – especially in cold and mixed climates.

Action Items

Resources

Wall Insulation

- 2 x 4 construction
- Existing drywall
- Insulating lower portion of wall



Key Concepts

Identify effective methods to insulate the walls of a converted garage.

Explanation

Regardless of the climate, it is likely that the existing walls of the garage will have been framed with 2"x4" dimensional lumber. If your heating or cooling needs are severe, it may be advisable to increase the R-value of the wall beyond that which is typical of a 3-1/2" cavity. Applying an inch of rigid foam to the interior of the studs is an option; or using a spray foam such as Corbond or soy-based foam insulation that has an insulating value up to R-7 per inch. Spray foam insulation is sprayed on (by a specialized contractor) as a liquid and expands to fill the cavity—providing air sealing and insulation in one step. In any climate in which air conditioning is used for significant periods during the cooling season, be sure to use an interior rigid foam board that is not a vapor retarder, e.g., do not use a foil-faced polyisocyanurate. In all climates, except perhaps severely cold (>8,000 HDD), it is recommended that no vapor retarder be used or only a "light" vapor retarder such as Kraft-faced insulation. As mentioned earlier, a vapor barrier with variable permeability, such as MemBrain, is also an option.

If the garage is already finished with drywall, a blown insulation such as cellulose may be the most cost-effective choice. If the walls are open, batts or blown insulation are probably the least expensive options.

When finishing garages, one area that may require attention to detail is the lower portion of the wall. Often, a garage has several courses of block above the floor level before framing starts. In order to provide some insulation to this area, it may be necessary to apply a rigid foam to the



Garage Finishing HVAC

- Challenges with:
 - Connecting area to existing HVAC system
 - Routing ductwork and pipes
 - Getting adequate airflow through long ducts
- Separate system may make sense



39

Key Concept

HVAC considerations for garage conversions.

Explanation

Heating or cooling a renovated garage space may be a challenge with respect to connecting the area to the existing central system. Certainly, the same care is needed in performing load calculations to ensure that existing equipment is adequately sized to handle the additional volume. In addition, routing ductwork or piping to a garage can be tricky in many cases. Walls or ceilings of the existing home may need to be opened up in order to run distribution lines to the garage.

Particular attention to sizing ductwork may be necessary to assure adequate airflow in long runs. Use ACCA Manual D for ductwork sizing.

Compared to a basement or attic conversion, a garage conversion may be an excellent place to consider independent heating or cooling equipment. Options might include a radiant wall or ceiling panel heating system, a high-efficiency sealed combustion gas fireplace, passive solar, or even electric resistance baseboard in moderate climates with modest electricity costs. For cooling, more efficient window unit air conditioners now exist. In areas with mild summers, carefully placed windows and/or ceiling fans may provide sufficient comfort. Electric resistance baseboard heaters are the least expensive option. Wall or ceiling radiant panels tend to improve occupant comfort and, because they are concealed, do not interfere with furniture placement. Keep in mind that overall electricity is an energy intensive way to provide space heating. Although 100% of the “site energy” is delivered as heat to the space, two-thirds of the “source energy” is lost in the process of

Sources of Supply Energy Efficiency Materials

- Hardware and building supply stores
- Online retailers, such as:
 - www.efi.org
 - www.sheltersupply.com
 - www.positive-energy.com
 - www.amconservationgroup.com



Key Concept



Sources of efficiency supplies

Explanation

Examples of items that can be purchased at these retailers include: Heat recovery ventilators, dehumidifiers, ENERGY STAR-rated fans.

Action Items

Resources

For More Information

- ENERGY STAR: www.energystar.gov
- The Energy Efficient Rehab Advisor (HUD) www.rehabadvisor.pathnet.org
- Fact sheets: www.eere.energy.gov/consumerinfo
- ToolBase Services: www.toolbase.org
- Virginia Energy Savers Handbook (Energy Use in Your Home) www.mme.state.va.us/de/handbook_one.html



41

Key Concepts

Explanation

Action Items

Resources

The ENERGY STAR Web site (www.energystar.gov) has information on various aspects of energy efficiency in remodeling.

The Energy Efficient Rehab Advisor (HUD) offers suggestions by climate, year of construction, and type of project (<http://rehabadvisor.pathnet.org/>)

The Energy Efficiency and Renewable Energy Web site of the U.S. DOE offers fact sheets on various remodeling projects and weatherization at www.eere.energy.gov/consumerinfo

The *Consumers' Guide to Home Energy Savings* lists the most energy efficient heating, cooling, and water heating equipment at <http://aceee.org/consumerguide/mostenef.htm>.

ToolBase Services: www.toolbase.org for information on innovative technologies and other useful information.

Virginia Energy Savers Handbook (Energy Use in Your Home; geared for consumers but contains a lot of useful information and diagrams) http://www.mme.state.va.us/de/handbook_one.html