

Roof Covering

VOL 3



Roofing Felt

Roof Sheathing

Metal Edge Clips
(see detail)

Standard Fink

THE **REHAB** GUIDE

ROOFS



PATH (Partnership for Advancing Technology in Housing) is a new private/public effort to develop, demonstrate, and gain widespread market acceptance for the “Next Generation” of American housing. Through the use of new or innovative technologies the goal of PATH is to improve the quality, durability, environmental efficiency, and affordability of tomorrow’s homes.

Initiated at the request of the White House, PATH is managed and supported by the Department of Housing and Urban Development (HUD). In addition, all Federal Agencies that engage in housing research and technology development are PATH Partners including the Departments of Energy and Commerce, as well as the Environmental Protection Agency (EPA) and the Federal Emergency Management Agency (FEMA). State and local governments and other participants from the public sector are also partners in PATH. Product manufacturers, home builders, insurance companies, and lenders represent private industry in the PATH partnership.

To learn more about PATH, please contact:

PATH
Suite B 133
451 Seventh Street SW.
Washington, DC 20410
202-708-4250 (fax)
e-mail: pathnet@pathnet.org
website: www.pathnet.org

DISCLAIMER

The statements and conclusions contained in this report are those of Steven Winter Associates, Inc. and do not necessarily reflect the views of the Department of Housing and Urban Development. Steven Winter Associates, Inc. has made every effort to verify the accuracy and appropriateness of the report’s content. However, no guarantee of the accuracy or completeness of the information or acceptability for compliance with any industry standard or mandatory requirement of any code, law, or regulation is either offered or implied. The products listed in the report are included only as examples of some available products. No endorsement, recommendation, or evaluation of these products or their use is given or implied.

ROOFS

VOLUME 3 OF THE REHAB GUIDE

TABLE OF CONTENTS

FOREWORD **3**

1. INTRODUCTION **4**
 2. ROOF DESIGN **6**
 3. SHEATHING **13**
 4. FLASHING **16**
 5. UNDERLAYMENTS AND MOISTURE BARRIERS **22**
 6. INSULATION **25**
 7. WOOD SHINGLES AND SHAKES **33**
 8. ASPHALT SHINGLES **37**
 9. LOW-SLOPE ROOFING **42**
 10. METAL ROOFING **48**
 11. SLATE **54**
 12. CLAY, CONCRETE, FIBER-CEMENT AND COMPOSITE TILES **58**
 13. GUTTER AND LEADER SYSTEMS **64**
- APPENDIX: PROFESSIONAL ASSOCIATIONS & RESEARCH CENTERS **74**

Prepared for:
U.S. Department of Housing
and Urban Development
Office of Policy Development
and Research

Prepared by:
Steven Winter Associates, Inc.
Building Systems Consultants
Norwalk, CT

Contract DUI00C000005956
March 1999

CREDITS

STEVEN WINTER ASSOCIATES, INC. STAFF MEMBERS
WHO WERE INSTRUMENTAL IN THE DEVELOPMENT AND
PRODUCTION OF THIS GUIDEBOOK INCLUDE:

Steven Winter
Principal-in-charge

Alexander Grinnell
Project manager and principal researcher

Michael J. Crosbie, Ph.D., RA
Editor-in-chief

Masaki Furukawa
Chief illustrator

Gordon Tully, William Zoeller
Project team members

U.S. DEPARTMENT OF HOUSING AND URBAN DEVELOPMENT
OFFICE OF POLICY DEVELOPMENT AND RESEARCH, AFFORDABLE
HOUSING RESEARCH AND TECHNOLOGY DIVISION

David Engel
Director

Nelson Carbonell
Senior architect

GUIDEBOOK DESIGN

Andrew P. Kner
Art Director

Michele L. Trombley
Assistant Art Director

Elizabeth Rosen
Symbols

FOREWORD

President Clinton recognizes that research and technological innovation are crucial if America is to meet its affordable housing needs. In 1998, the President introduced a major new initiative: The Partnership for Advancing Technology in Housing (PATH). This initiative brings together leaders from the home building, product manufacturing, insurance, and financial industries, as well as representatives from federal agencies, to spur housing design and construction innovations.

Thanks to the development of new machinery and materials and the creation of new technologies and techniques, the construction industry has made great progress. But a breakthrough material, a labor-saving tool, or a cost-cutting technique is only valuable if it is widely adopted, which means the construction industry must first become aware of these new developments.

The Department of Housing and Urban Development can help. We have commissioned a set of guidebooks that will present state-of-the-art techniques, materials, and technologies for housing rehabilitation. This volume, *Roofs*, is the second of nine guidebooks--known collectively as *The Rehab Guide*--that will appear over the next few years.

We are presenting these guidebooks because, like research and technological innovation, housing rehabilitation is an essential component of America's commitment to provide affordable housing. I am pleased to present this important publication in the hope that it will become a valuable resource that leads to affordable, high quality rehabilitation, and thus to better housing for all Americans.

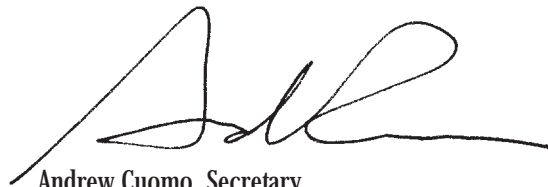
A handwritten signature in black ink, appearing to read 'Andrew Cuomo', with a long horizontal stroke extending to the right.

Andrew Cuomo, Secretary
U.S. Department of Housing and Urban Development

THE REHAB GUIDE: ROOFS

INTRODUCTION

This publication, *The Rehab Guide: Roofs* is one in a series of guidebooks produced by the U.S. Department of Housing and Urban Development (HUD) to keep the design and construction industry abreast of innovations and state-of-the-art materials and practices in home rehabilitation. As is too often the case, innovative techniques, materials, technologies, and products are slow to make their way into accepted practice. *The Rehab Guide* series is intended to accelerate this process by informing builders, architects, engineers, and other housing rehabilitation professionals about such innovations and state-of-the-art practices.

The Rehab Guide was also prompted by the lack of a comprehensive publication to make the design and construction industry aware of innovative and cost-saving developments in housing rehabilitation. Professional trade magazines, conferences, and trade shows offer some distribution of this information, but they are rarely focused on housing rehabilitation, as this series is, nor are they comprehensive. It is evident that such innovations will not advance unless the industry is made aware of them and they are tested.

FOCUS OF THE REHAB GUIDE

The focus of this series is on housing rehabilitation, which is different than home improvement. Rehabilitate means “to restore to good condition,” not necessarily to improve to a state that is significantly different than the original. This is a fine line, but it distinguishes this series from “home improvement” books written for the amateur. *The Rehab Guide* focuses on building technology, materials, components, and techniques rather than “projects” such as adding a new room, converting a garage into a den, or finishing an attic. Nor is *The Rehab Guide* intended to be a “diagnostic” tool; a number of such books are already available to the industry.

The content for this guidebook, *Roofs*, has been gathered from professionals in the housing rehabilitation field; manufacturers and suppliers of innovative technologies, materials, components, tools, and equipment; trade shows, conferences, reports, and publications considering such issues; trade organizations; and building research centers.

A NOTE ON SOURCES

Particularly useful sources of technical information on roofing design and detailing are publications by the National Roofing Contractors Association (NRCA), the Asphalt Roofing Manufacturers Association (ARMA), the Sheet Metal and Air Conditioning National Contractors Association (SMACNA), the Copper Development Association (CDA), and other industry associations. Other valuable and detailed sources of information from the general construction industry include installation manuals from individual product manufacturers, technical trade magazines such as *Construction Specifier*, *Roofing Contractor*, and *RSI: Roofing, Siding, Insulation*. Publications relating more directly to residential construction include the *Journal of Light Construction*, *Old House Journal*, *This Old House*, *Fine Homebuilding*, *Environmental Building News*,

and *Energy Design Update*. A number of home repair and improvement books are available that include information on maintenance and repair of building materials. Some of these contain dated information; however, among the more useful publications, are those published by Ortho Books. A valuable source of publications on construction issues is the Canada Mortgage and Housing Corporation, which has an extensive catalog of excellent books and articles on a wide range of subjects on housing construction and rehab. The most complete and comprehensive books on roofing topics are the *Residential Steep-Slope Roofing Material Guide* and the *Steep-Slope Roofing Manual*, both produced by and available from NRCA. For individuals interested in historic preservation, the Technical Preservation Service Bureau of the National Park Service through its web site (www2.cr.hps.gov) has a wealth of reliable information on building materials and preservation technologies. The last few years has seen a proliferation of web sites addressing building materials and technologies. Virtually every building-related association, publication, and manufacturer has its own web site. These have become very useful and accessible sources of information.

HOW THE GUIDE IS ORGANIZED

Nine volumes will eventually make up *The Rehab Guide* in its entirety, and they are listed on the back cover of this volume. Each one is devoted to distinct elements of the house, and within each volume is a range of issues that are common to that element of home rehabilitation work. This volume, *Roofs*, for example, covers the major roofing systems including framing and sheathing; protective strategies such as underlayments and flashing; energy and air infiltration issues; roofing materials; fasteners; and gutters and downspouts. Each volume addresses a wide range techniques, materials, and tools, and recommendations based on regional differences around the country. Throughout *The Rehab Guide*, special attention is given to issues related to energy efficiency, sustainability, and accessibility.

EASILY ACCESSIBLE FORMAT

The Rehab Guide is written and presented in a format intended for easy use. The spiral bound volumes open flat so that they can be easily photocopied, and they can be assembled and stored in a single three-ring binder. Within each volume, drawings, photos, and other graphic materials supplement written descriptions of a broad range of items: state-of-the-art and innovative building technology, products, materials, components, construction and management techniques, tools, equipment, software—virtually any and all items that make housing rehabilitation more efficient in terms of cost and time. While the content focuses on present technologies, techniques and materials that are currently part of the house-building industry, *The Rehab Guide* also includes information on materials, products, and procedures from other construction sectors (such as commercial, industrial, institutional) that are relevant to housing rehabilitation.

The information is organized in different sections according to rehab subjects, and under headings that make this book easy to understand. “Essential Knowledge” gives the reader a basic overview of the important issues related to the section heading. Next, “Techniques, Materials, Tools” presents state-of-the-art and innovative approaches to accomplishing the work. Each entry is explained in detail, including its advantages and disadvantages. This makes it easy for readers to compare approaches and choose the one that is most applicable to their particular project. By design, the “Techniques, Materials, Tools” section is an overview, not a detailed description of implementation. “Further Reading” lists the valuable resources relevant to the subject which readers can go to for more detailed information. Finally, “Product Information” provides names and addresses of manufacturers of products, materials, systems, and components mentioned in the text so that more information can be attained. By virtue of their being listed here, such products are not necessarily being recommended; their existence and availability is being brought to the reader’s attention. New products should be carefully evaluated in the field as to their efficacy. The product lists are not comprehensive, and we encourage readers to bring new materials and products to our attention to be included in later editions of *The Rehab Guide*.

2

ROOF DESIGN

2.1

ROOF SYSTEMS OVERVIEW

The performance of a building's roof is key to the integrity of the structure and the comfort and well being of the occupants. Roof failures run the gamut from catastrophic structural failure from earthquakes, fire, snowstorms, tornadoes, and hurricanes to major leaks caused by falling tree limbs and the intrusion of wind-driven rain under roof shingles or tiles. Damage is also caused by deterioration of roof sheathing and saturation of insulation from ice damming and wind-blown moisture into attic spaces through soffit, gable-end, and ridge vents. Minor leaks due to improper caulking or flashing at roof penetrations, or roof/wall intersections are also common.

This guideline will provide an overview and reference resource for information about roofing systems, subsystems, and materials; a review of current theory in terms of performance of these systems; and a discussion of existing or new materials, techniques, or components that have recently been improved or that represent totally new product lines.

The *Guide* is primarily about rehabilitation, so structural issues will involve retrofitting buildings to protect against catastrophic failure, from such phenomena as wind and earthquakes. Basic framing errors and their correction are outlined, but not discussed in detail. They are treated in a number of publications published by the *Journal of Light Construction* and other sources (see Further Reading).

Protective strategies are undergoing considerable review and a number of issues remain controversial, including the effectiveness of air infiltration and vapor retarders and the desirability of ventilating attic spaces in cooling climates. As there is currently limited conclusive test data, the differing concepts will be presented, when relevant, to inform the reader of the issues involved. Issues regarding insulation alternatives are also presented to inform the reader with an understanding that some of the current strategies have yet to receive consensus.

In the fairly recent past steep-sloped residential roofing selection was relatively simple: the choice was between three-tab asphalt shingles, cedar shingles or shakes, clay and possibly concrete roofing tiles, or, in a smaller number of cases, slate. Today, these same basic choices are available, but these materials have evolved considerably, particularly the development of high-profile laminated asphalt shingles, new tile shapes and colors, and new protective treatments for shingles and shakes. In addition, a whole new set of materials has come into mainstream use including metal shingles, shakes, and tiles; fiber-cement and plastic profiles that simulate wood and slate; and new materials and detailing for conventional systems such as standing seam metal roofing. Low-slope roofing systems have also evolved with the increased use of modified bitumen membranes and single-ply roofing systems. This guideline will review the attributes of steep- and low-sloped systems and materials with the intent of outlining some of the apparent advantages and disadvantages. These attributes are not necessarily comprehensive and readers are advised to undertake their own research of individual products and their respective warranties. Detailed price comparisons have been avoided because of the fluctuating nature of prices and wide geographic variance.

Recommendations regarding the removal and disposal of asbestos roofing tiles have not been included because they are available from the Environmental Protection Agency's (EPA's) Asbestos Information Hotline: 800-438-2474 as well as industry sources such as the National Roofing Contractors Association, which publishes a guide titled: *A Practical Guide for Handling Asbestos-Containing Roofing Material*. Information regarding the removal of lead-based paint is also available from the EPA (800-532-3394).

ESSENTIAL KNOWLEDGE

One of the most telling aspect of a roof's condition is the condition of the ridge. Swayback (sagging) roofs can indicate a number of problems including: lack of or insufficiently sized structural ridge beam; insufficiently sized roof rafters; missing or misplaced collar ties; improper rafter heel bearing; lack of solid blocking at the heel; inadequate rafter bracing or rafter bracing that is not transferred to a structural member such as a bearing wall or column; or interior column displacement due to settled footings. Common problems with trusses include trusses bearing on interior partitions when they are designed to span to the sidewalls; truss members cut to accommodate ductwork or equipment in the attic space; and lack of lateral bracing of top and bottom truss cords.

TECHNIQUES, MATERIALS, TOOLS**REPAIR FRAMING.**

The repair of some sloped roofing problems can be accomplished by placing column supports or a supporting beam under the ridge board/beam and jacking it up to take most of the load off of the rafter heel/top plate connection. When this is accomplished, the walls can be pulled together, collar ties, ceiling joists, tension members or intermediate supports added, and rafters refastened, repaired, replaced, or rebraced. In some instances, inadequately sized roof sheathing may have sagged between rafters, resulting in a wavy roof surface. If this condition exists, new sheathing is required.

Most roofing problems, particularly on sloped roofs with multiple, complicated intersections can only be identified after a thorough, systematic analysis of the roof's structural components and a documentation of systems and possible causes. Because of the great variety of defective conditions and possible causes, it is impossible to provide generalized repair guidelines.

If the structure has excessive deformation, if termite, fire, or dryrot damage is severe, or if the materials used were inferior, it may be wise to gut the structure and reframe it, or demolish all or portions of the structure and rebuild. Low-sloped roof problems are frequently caused by undersized rafters or rafters and sheathing that have deteriorated from rot from roof leaks or moisture condensation. Typical corrective work includes adding new rafters (sistering) adjacent to deficient ones. Project-specific structural repairs should be determined by job conditions and should be reviewed with a licensed professional engineer or architect.

ADVANTAGES: Retains as much of the existing structure as possible. Does not necessarily require the replacement of the finish roofing material; least obtrusive repair. Generally cost effective.

DISADVANTAGES: Jacking of ridge may not eliminate roof swayback or wall bulge at top plate. May require removal of interior wall and ceiling finishes and more extensive reconstruction. Correcting extensive fire- or moisture-related problems may require considerable demolition, reframing and new materials.

FURTHER READING

"Advanced Framing—Techniques, Troubleshooting and Structural Design," the *Journal of Light Construction*, 1992.

Renovating Old Houses, George Nash, Newtown, CT, Taunton Press, 1996.

Renovation: A Complete Guide (Second Edition), Michael W. Litchfield, New York; Prentice Hall, 1991.

The Old House Guide to Restoration, edited by Patricia Poore, New York: Dutton, 1992.

“The Structure of Wood Frame Homes,” Gordon Bock, *Old-House Journal*, March/April 1992.

Troubleshooting Guide to Residential Construction, The Journal of Light Construction, 1997.

Wood-Frame Construction Problems, Canadian Mortgage and Housing Corporation, 1989, revised 1995.

2.3

WOOD FRAME WIND RESISTANCE

ESSENTIAL KNOWLEDGE

The increased number and severity of recent catastrophic wind storms and hurricanes has underlined the need for homeowners to assess the structural condition of their houses. Inspections of houses in the aftermath of hurricane Andrew in 1992 indicated that much of the existing housing was not designed to resist high winds or such provisions were not constructed properly. It is important to understand that a building's roofs and walls resist wind loads in a complex manner distributing gravity loads and acting as shear walls and diaphragms to resist and distribute lateral wind loads. In high winds they have to resist very significant uplift forces as well. All the structural elements should act to provide a continuous load transfer path from the roof structures to the walls and floors and into the foundation. This only works when all the elements are well connected, which is not usually the case. Analyses of roof failures indicate typical failures at wall-to-roof connections, roof sheathing-to-roof rafter or truss connections; and the bracing of rafters or trusses to each other to prevent progressive “dominoing.” Other failures include the loss of roofing material which adds to flying debris, breaking windows and allowing water to penetrate into interior spaces.

A recently published brochure from the Institute for Business and Home Safety (IBHS) (a research and communications arm of the insurance industry) titled *Is Your Home Protected from Hurricane Disaster?—A Homeowner's Guide to Hurricane Retrofit*, represents one of the most current guidelines on retrofit recommendations. Recommendations include: the inspection of the roof components; addition of wall/roof tie downs; refastening of roof sheathing; the refastening or replacement of finished roofing products; the reinforcement of rafter/truss sheathing connections with adhesives; the reinforcement of gable and wall connections and many other recommendations (see Further Reading).

TECHNIQUES, MATERIALS, TOOLS

1. REINFORCE EXISTING STRUCTURE WITH METAL CONNECTORS, STRAPS, AND ADDITIONAL FASTENERS.

One of the recommendations of the IBHS is to remove the existing finish roofing material and underlayment, remove the bottom row of roof sheathing, and install new fasteners at each truss/rafter wall connection. The size and model of the connector will depend on the field condition and uplift resistance requirement. Simpson Strong-Tie Company, Inc. has prescriptive guidelines for simple building types, but in general the advice of a registered professional engineer should be sought. Typical fastener types are shown in Figs. 1 and 2. Once the connectors are in place, the roof sheathing can be reinstalled, the entire sheathing reinforced with additional fasteners, and new wind-resistant finished roofing applied. As an alternate to removing the roof sheathing, connectors can often be installed by removing the building's soffits. Currently, there are no connectors available that can be installed from existing attic spaces, but some manufacturers are researching possible design solutions.

ADVANTAGES: Rafter/truss connectors have proven to be very effective against uplift forces. In conjunction with reinforcing the sheathing fastening, probably the most recommended step to strengthen the building's structure.

DISADVANTAGES: Requires removal of a portion of the roof sheathing or soffit.

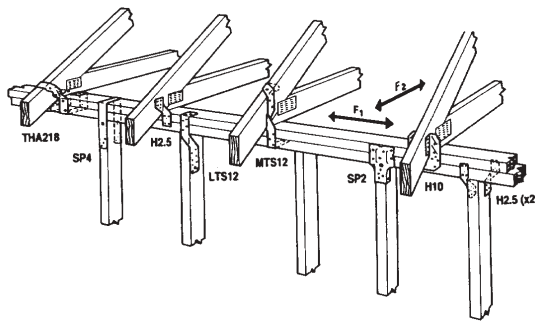

FIGURE 1

TYPICAL STUD WALL TO TRUSS CONNECTORS

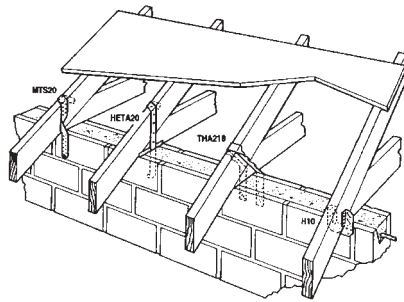

FIGURE 2

TYPICAL MASONRY WALL TO TRUSS CONNECTORS

2. REINFORCE EXISTING ROOF SHEATHING TO RAFTER/TRUSS CONNECTION WITH ADHESIVES.

A promising technology that is currently under development is the use of adhesives to connect building components such as roof sheathing and rafters/trusses. One of the pioneers in this field, ITW Foamseal, Inc., manufactures a structural urethane foam adhesive that is widely used to attach gypsum ceilings to trusses in the manufactured housing and modular industries. Foamseal has developed a product, SF 2100, that is currently being installed in a number of homes in coastal South Carolina. Foamseal has also applied for acceptance of this product in a number of Florida counties.

ADVANTAGES: Forms a continuous fillet weld that attaches and stiffens the components of the entire roof structure. Can also be applied to joints in the sheathing to prevent the intrusion of water. Applicator does not need to have physical contact with the joint as the spray has a range of approximately 10 feet (other construction adhesives would require that the adhesive gun be in contact with the joint). A cost-effective technique to connect the roof framing and sheathing. Considerably less costly than removing sheathing and applying metal connectors.

DISADVANTAGES: Does not address connection of roof truss/rafter with top of wall plate. The stiffening of the roof sheathing may cause stress and load transfers to other structural members with difficult-to-determine results. The services of a professional engineer may be required to review application.

3. REINFORCE EXISTING ROOF-TO-WALL CONNECTION WITH KEVLAR STRAPS.

A new material development, Millibar V 220, distributed by New Necessities, Inc. utilizes 0.05-by 3-inch thick wide Kevlar straps that can be run from the foundation, up the side wall over the roof and back down the other side to resist windloads due to hurricanes, tornadoes, and severe storms.

ADVANTAGES: Extremely strong 525,000 psi tensile strength. Will not corrode or rot; impervious to heat, cold salt air, and water. Versatile, can be used as needed. Easily fastened, creates continuous load path.

DISADVANTAGES: A supplemental restraining system used in conjunction with conventional fasteners, straps and connectors. Requires removal of roofing and siding material. Requires project-specific engineering. Can be costly.

FURTHER READING

Building in High Wind and Seismic Zones—Design Concepts, APA - The Engineered Wood Association, 1997.

Buildings at Risk: Wind Design Basics for Practicing Architects, American Institute of Architects, 1735 New York Avenue, NW, Washington, DC 20006–5292.

Coastal Construction Manual, Federal Emergency Management Agency (FEMA), 500 C Street, SW, Washington, DC 20006; 800–480–2520; www.fema.gov; February 1986 (being revised).

Is Your Home Protected from Hurricane Disaster?—A Homeowner's Guide to Hurricane Retrofit, Institute for Business and Home Safety, 73 Tremont Street, Suite 510, Boston, MA 02108–3910; 617–292–2003; www.ibhs.org; 1997.

Standard for Hurricane Resistant Residential Construction—SSTD 10-96, Southern Building Code Congress International, Inc., 900 Montclair Road, Birmingham, AL 35213–1206; 205–591–1853.

Wood Frame Construction Manual for One and Two-Family Dwellings—High Wind Edition, 1995 SBC, American Forest & Paper Association—American Wood Council, 1111 19th Street, NW, Washington, DC 20006; 202–463–2700; www.afandpa.org.

PRODUCT INFORMATION

High Wind Resistant Construction Connectors, Simpson Strong-Tie® Company, Inc., 4637 Chabot Drive, Suite 200, Pleasanton, CA 94588; 800–999–5099; 1995; www.strongtie.com.

ITW Foamseal, 2425 North Lapeer Road, Oxford, MI 48371, 248–628–2587, www.itwfoamseal.com

New Necessities, Inc., 5710 Pebblebrook Trail, Gainesville, GA 30506, 770–844–9438

2.4

WOOD FRAME SEISMIC RESISTANCE

ESSENTIAL KNOWLEDGE

Strengthening existing residential buildings to resist earthquakes is focused primarily on the strengthening of connections of the structure to the foundations and, to a lesser extent, the provision of shear walls and the connection of walls to floors. The existing literature and prescriptive recommendations for the seismic retrofit of residential buildings makes very little mention of roof to wall connections except to recommend that a continuous load path be provided where possible from the roof to the foundations. An engineer designing a new residential building (especially with heavy roof tiles) would, however, most likely specify some wall/roof connector to resist lateral forces induced by ground motion. Wall/roof reinforcement requirements should be considered as part of an overall study of structural performance.

TECHNIQUES, MATERIALS, TOOLS

REINFORCE EXISTING WALL/ROOF CONNECTIONS.

The connections available to provide resistance to seismic forces are those also used to resist high winds. Whereas they are effective in strengthening the building frame they are not normally prescribed for existing housing. Individual structures, however, have unique requirements and the assistance of a professional engineer is required to make building-specific recommendations.

ADVANTAGES: Strengthens building envelope.

DISADVANTAGES: Not usually as cost-effective as reinforcing foundations and shearwalls.

FURTHER READING

A Guide to Strengthening and Repairing Your Home Before the Next Earthquake, Developed by the Governor's Office of Emergency Services, State of California, and the Federal Emergency Management Agency, revised May 1995. Association of Bay Area Governments (ABAG) Publications, P.O. Box 2050, Oakland, CA 94604–2050; www.abag.ca.gov.

An Ounce of Prevention: Strengthening Your Wood Frame House for Earthquake Safety: A Do-It-Yourself Program, Video and book. Governor's Office of Emergency Services, State of California, 1993. Association of Bay Area Governments (ABAG) Publications, P.O. Box 2050, Oakland, CA 94604–2050; www.abag.ca.gov.

Buildings at Risk: Seismic Design Basics for Practicing Architects, AIA/ACSA Council on Architectural Research, National Hazards Research Program, 1735 New York Avenue, NW, Washington, DC 20006, 1994.

How the City of San Leandro Can Help Strengthen Your Home for the Next Big Earthquake in the Bay Area (publication includes prescriptive details). The City of San Leandro Development Services, Building Regulation Division, 835 East 14th Street, San Leandro, CA 94577; 510–577–3405.

Prescriptive Seismic Strengthening Plan for Wood-Frame Residential Structures, Simpson Strong-Tie Company, Inc. www.strongtie.com.

The San Francisco Bay Area — On Shaky Ground. Association of Bay Area Governments, 1995 (multi-media CD-ROM, 1996). Association of Bay Area Governments (ABAG) Publications, P.O. Box 2050, Oakland, CA 94604–2050; www.abag.ca.gov.

“Tying Down the House,” John Scoggins, *Journal of Light Construction*, September 1997.

PRODUCT INFORMATION

Earthquake Resistant Construction Connectors, 1995, Simpson Strong-Tie® Company, 4637 Chabot Drive, Suite 200, Pleasanton, CA 94588; 800–999–5099; www.strongtie.com.

2.5

STRUCTURAL DECAY

ESSENTIAL KNOWLEDGE

Water absorbed by structural wood-framing can raise its moisture content, reduce its compressive and tensile strength, and ultimately allow for rot, decay, and the corrosion of metal fasteners and truss plates. Fungi attack cellulose in the cell walls of roof framing members when three conditions exist: moisture, the presence of air, and a temperature range between 6 and 86° F (20 to 30°C). The best way to prevent decay is to eliminate moisture.

TECHNIQUES, MATERIALS, TOOLS

CONTROL MOISTURE INTRUSION.

The most effective ways of reducing moisture in attic spaces are to prevent warm moist air from rising through openings in ceilings of occupied spaces; maintain weathertight roofs and walls; prevent rain and snow from infiltrating through ridge, soffit, gable end, or other venting devices; and provide sufficient ventilation of attic spaces. The process of rehabbing buildings affords the opportunity to install the necessary weather barriers and moisture retarders. These issues and implementation alternatives are discussed throughout the various chapters of the *Guide* in particular *Section 6: Insulation*.

2.6 FIRE DAMAGE

ESSENTIAL KNOWLEDGE

Damage from fire can range from the total loss of a building and its contents to minor inconvenience from smoke odors. The process of determining the restoration requirements of a fire-damaged building varies considerably with the building's location and extent of damage. Insurance adjusters often make settlement offers based on their own evaluation of restoration needs, although they may employ consultants on more complex projects. Recommendations may also originate from local fire marshalls, building department officials, contractors, or consulting engineers, industrial hygienists, public adjusters, and architects hired by the building owner. Unless the damage is limited, the restoration process can be complex involving structural, electrical, HVAC, plumbing systems, as well as building finishes. In addition, significant health and comfort issues arise from the residual smoke, combustion gases, moisture from fire department hoses, and the existence of products containing asbestos. For this reason the selection of a restoration contractor who is experienced and knowledgeable in current techniques is critical. At least one national association, the Association of Specialists in Cleaning and Restoration (ASCR) manages training and certification programs and publishes a restoration guideline.

TECHNIQUES, MATERIALS, TOOLS

RESTORE FIRE-DAMAGED ROOF ELEMENTS.

The first step in a restoration project is to assess the damage to the building's structure, systems, and finishes. In 2 by 4 construction, significantly charred members are generally removed in their entirety. Heavy timber construction can remain if, according to the American Society of Civil Engineers, once the char is removed, the remaining section is still structurally adequate (after a reduction-in-size-factor of 1/4 inch on all sides). Char is removed by scraping and abrasive blasting. It should be removed because it holds odors, although encapsulating coatings will inhibit their transmittal. Sheathing materials, especially charred or unsound fire-retardant-treated material, should also be removed. New construction, replacing the damaged elements, should meet codes for new construction. Smoke-damaged materials should be cleaned and deodorized as necessary. Water-damaged materials, such as insulation, should be replaced when the damage is irreversible.

ADVANTAGES: Allows for rehabilitation of fire damaged buildings.

DISADVANTAGES: May not be cost-effective for severely damaged structures.

FURTHER READING

Evaluation Maintenance and Upgrading of Wood Structure, American Society of Civil Engineers.

NIDR – Guidelines for Fire and Smoke Damage Repair, National Institute of Disaster Restoration (a division of the Association of Specialists in Cleaning and Restoration); 1997. 301–684–4411; www.ascr.org.

ESSENTIAL KNOWLEDGE

Roof sheathing serves a number of functions. It is a key element in the barrier system that keeps out moisture; it serves as a nail base and support of roofing materials; it connects and braces the individual roof trusses or rafters; it provides a diaphragm that, in combination with shear walls, stiffens the entire house against lateral forces from wind and earthquakes.

Roof sheathing in older houses (before the 1950s) is typically 1x boards, either tongue-and-groove, butt-edged, or spaced, and laid perpendicular to the rafters. Houses built since the mid-'50s most likely have plywood, particleboard, or oriented strand board (OSB) sheathing thinner than $\frac{3}{4}$ inch. Exceptions to this are post-and-beam houses with rafters at 4 feet or greater spacing, with 2x tongue-and-groove decking, $1\frac{1}{8}$ inch plywood or OSB, or other structural sheathing material such as Homasote, that is designed for longer spans than typical wood structural panel sheathing.

Plywood and oriented strand board are today's leading roof sheathing materials, together accounting for over 95 percent of the market. Currently, slightly more plywood is used than OSB, but the latter material is expected to dominate the market within the next few years, and already has in some regions. It is important to understand that APA – The Engineered Wood Association (APA) does not differentiate between plywood and OSB under its APA Rated Sheathing program. Nor is APA the only quality assurance agency that certifies that plywood or OSB meet the voluntary product standards that have been set by the National Institute of Standards and Technology (NIST), to which the industry generally conforms. The two product performance standards that are in use are: *Voluntary Product Standard DOC PS 1-95 for Construction and Industrial Plywood*, and *Voluntary Product Standard DOC PS 2-92 for the Performance Standard for Wood-Based Structural-Use Panels*. DOC PS 1-95 refers only to plywood, DOC PS2-92 allows the flexibility for the supplier to obtain plywood or OSB if there is no preference. DOC PS 1-95 is a prescriptive manufacturing standard, DOC PS2-92 is a performance standard. The performance requirements for wood structural panels set forth by both standards are the same. Many in the industry refer to colloquial terms such as “CDX” plywood. This is not a recognized grade in the product standards. A better specification for this item would be (under the APA designation) Rated Sheathing, Exposure 1, DOC PS 1-95, for plywood only, or Rated Sheathing Exposure 1, DOC PS 2-92 when there is no preference between plywood or OSB. The reference to a product performance standard should be evident in the stamp of the third party grading agency that appears on individual panels. Exposure 1 panels are panels that have a waterproof bond and are designed for prolonged exposure prior to application of final roofing material.

Fire-retardant-treated (FRT) plywood sheathing, with a flame spread rating no greater than 25 when tested for 30 minutes in accordance with American Society for Testing Materials (ASTM) E84, is available from a number of producers. FRT OSB is not available because the wood swells unpredictably and a reliable impregnation process has yet to be developed. FRT plywood sheathing is not normally used in detached one- and two-family housing, although it is used in multifamily housing and occasionally in attached single-family housing. The surface of the FRT plywood is designed to char at high temperatures in order to prevent sustained burning. The use of high amounts of ammonium phosphate in products during the 1980s led to a chemical reaction caused by high attic temperatures (150 to 170°F), induced by solar radiation and the presence of moisture in the air. This chemical reaction led to substantial wood degradation of FRT roof sheathing on a number of housing projects, requiring, in many cases, the complete removal of sheathing and finished roofing. Fortunately, according to the U.S. Forest Products Laboratory, most of the deficient material has been replaced and the new standards developed by the American Wood Preservers' Association (AWPA) and ASTM have led to new formulations which have largely controlled the problem.

TECHNIQUES, MATERIALS, TOOLS

1. REPAIR EXISTING ROOF SHEATHING.

If the finished roofing material has been well maintained, the sheathing should not have deteriorated. Exceptions to this would be damage from: fire; inadequate roof structure; hail; airborne debris from high winds; localized problems including rot caused by leaks at improperly flashed roof penetrations such as at vent stacks, skylights, chimneys, etc; damage to the leading edge of the roof from ice damming; deterioration of the sheathing from condensation caused by inadequate venting of moist air from the attic space; swelling of sheathing edges caused by inadequate protection from rain during original construction; and deterioration of FRT sheathing caused by excessive heat and humidity.

The condition of the existing roof sheathing can be assessed by visual and physical means. Visual signs of deterioration include obvious delamination or deterioration, the existence of water stains, dark patches, mold spores, insect holes and charring of the sheathing and roof structure. Physical assessment employs probes and soundings to determine the presence of soft, crumbling, split, swollen, or otherwise degraded material.

Sheathing that cannot function well as a nail base and support for roof finishes and as a brace to the roof structure should be replaced. If the deteriorated area is small, it may be able to be patched without extensive reroofing, or treated with a fungicide in the event it is caused by mold. For the most part, however, deterioration, if it exists, is likely to be widespread and may require partial or complete removal of the sheathing and the existing finish roofing as well. The specific removal requirements and techniques will depend on individual on-site conditions.

ADVANTAGES: Repairs are cost-effective when the affected area is relatively small and the remaining sheathing is sound.

DISADVANTAGES: If the deterioration is widespread, the building's structure will be compromised. In this instance, the affected sheathing should be replaced.

2. REPLACE DAMAGED EXISTING ROOF SHEATHING WITH PLYWOOD.

Plywood is made of thin sheets of wood veneer (or plies) arranged in cross-laminated layers to form a panel. Plywood always has an odd number of plies consisting of three or more layers. Plywood is available in a wide variety of thicknesses, from $\frac{5}{16}$ to $1\frac{1}{8}$ inch, with span capabilities from 12 to 60 inches (with edge support). APA has recommended span and load tables for various combinations of panel thicknesses and grades.

ADVANTAGES: The material of choice for many years. Excellent structural and durability characteristics. Used as a nail base for almost every type of finished roofing application.

DISADVANTAGES: More expensive than OSB and becoming more so. Expected to continue to lose market share to OSB.

3. REPLACE DAMAGED EXISTING SHEATHING WITH OSB.

Made with rectangular-shaped wood strands cross-oriented in layers for better structural performance, OSB has replaced particleboard, "flakeboard," "chipboard," and "waferboard" as the most popular alternative to plywood sheathing. It typically comes in 4 by 8 panels (1.25 by 2.5 meter sizes are available from some manufacturers), but can also be custom ordered in lengths up to 24 feet and widths up to 12 feet. OSB can be manufactured with square or tongue-and-groove edges. OSB is available in the same thicknesses as plywood, from $\frac{5}{16}$ to $1\frac{1}{8}$ inch.

ADVANTAGES: Available nationwide, significantly less expensive than plywood and becoming more so. An excellent nail base for a wide variety of finish roofing materials. Uses smaller, younger trees and fast-growing species previously underutilized. OSB has the same waterproof adhesives as plywood.

DISADVANTAGES: Edges can swell when exposed to moisture. APA recommends sanding edges down again (this has no structural effect on the panel).

4. REPLACE DAMAGED EXISTING ROOF SHEATHING WITH TONGUE & GROOVE WOOD DECKING.

Some post and beam structures utilize exposed 2 by 4 inches and 2 by 6 inches T&G roof decking in conjunction with widely-spaced exposed roof rafters or trusses. T&G decking can span over 8 feet depending on species and loading conditions. Exposed decking systems typically have roof insulation on top of the roof (see Section 6, *Insulation*).

ADVANTAGES: Cost-effective with widely spaced trusses. Provides attractive finished ceiling. Decking provides nail base for insulation or batten systems used to support finished roofing.

DISADVANTAGES: Generally more expensive than other framing/sheathing alternatives. Requires substantial thickness of insulation above the sheathing to reach required R-value with attendant problems of fastening and venting the finished roofing products.

5. REPLACE DAMAGED EXISTING ROOF SHEATHING WITH FIBERBOARD SHEATHING/DECKING.

Fiberboard roof sheathing products have been in existence since 1908. The dominant manufacturer, Homasote Company, makes a structural sheathing, Easy-ply®, in thicknesses from 1 to 2¹/₁₆ inches designed to span from 16 to 48 inches with an R-value of 2.4 for 1-inch to 5 for 2¹/₁₆-inch thickness. Easy-ply® has a class C fire rating. A specially treated Firestall® has a class A rating.

ADVANTAGES: Better insulator than wood decking. Can be obtained with a class A rating. Prefinished. Available T&G. Long history of use. Cost-effective on 48-inch spans. Water resistant. Resource-conserving, made from recycled paper with wax emulsion.

DISADVANTAGES: More costly than some competing products such as OSB on short spans. R-factor not significantly better than wood. T&G 2³/₈-inch decking with a R of 5 still needs rigid insulation on top. Not as strong as OSB or plywood.

FURTHER READING

House Building Basics, APA FORM X461, APA—The Engineered Wood Association, 1997.

Oriented Strand Board, APA FORM W410, APA—The Engineered Wood Association, April 1996.

Residential & Commercial Design/Construction Guide, APA FORM E30, APA—The Engineered Wood Association, 1996.

Roof Alterations and Renovations, APA FORM M325, APA—The Engineered Wood Association, 1991.

PRODUCT INFORMATION

APA—The Engineered Wood Association, P.O. Box 11700, Tacoma, WA 98411-0700; 253-565-6600; www.apawood.org.

Homasote Company, Box 7240, West Trenton, NJ 08628; 800-257-9491; www.homasote.com.

ESSENTIAL KNOWLEDGE

Residential roofing is typically made up of a multitude of materials and surfaces whose primary task is to maintain a barrier between the interior and the weather. The most pervasive and difficult weather element to control is water. Roof flashing is usually the last line of defense in the battle against water penetration.

Flashing forms the intersections and terminations of roofing systems and surfaces, to thwart water penetration. The most common locations for roof flashing are at valleys, chimneys, roof penetrations, eaves, rakes, skylights, ridges, and at roof-to-wall intersections. Flashing must be configured to resist the three mechanisms of water penetration: gravity, surface tension, and wind pressure. To achieve this, flashing can be lapped shingle style, soldered or sealed to function as a continuous surface, or can be configured with a non-continuous profile to defeat water surface tension. Flashing materials must be durable, low in maintenance requirements, weather resistant, able to accommodate movement and be compatible with adjacent materials. Common modes of failure include exposure to salt air, excessive heat, acid rain, heavy snows, and scouring winds.

Traditional materials and methods of installing flashing produce some of the longest lasting of building systems components. Those methods do, however, require experience and are time consuming. Newer membrane materials and modern sealants are available that complement time-tested techniques, but, regardless of the methods and materials employed, the basic principles of roof flashing must still be adhered to, and the three water penetration mechanisms must be overcome.

TECHNIQUES, MATERIALS, TOOLS

Roof flashing materials can be classified into two primary groups: membrane and sheet metal. Ice and water barriers and roll roofing are membranes. The most typical sheet metal flashing materials are aluminum, copper, lead-coated copper, lead, stainless steel, galvanized steel, zinc, and Galvalume™. Both sheet metal and membrane flashing are available unformed or, for some particular applications, in pre-formed configurations.

1. REPAIR EXISTING FLASHING.

Small areas of loose, bent, split, corroded, or otherwise deficient flashing can often be reinstalled, permanently patched with similar material, or can be replaced with new flashing. Asphaltic patching material is adequate for asphaltic roofs, but is not recommended for metal flashing because it will break down from ultraviolet (UV) exposure and movement of the metal. It is also unsightly and an indication of poor maintenance. If large sections of flashing have deteriorated or have become loose or disengaged, it is time to remove the roofing material and install new membranes and flashing.

ADVANTAGES: Repairs are cost-effective over small areas.

DISADVANTAGES: If large areas need replacement, or if serious leaks develop, postponing replacement may cause damage to the building's structural elements or finishes.

2. INSTALL NEW COPPER OR LEAD-COATED COPPER FLASHING.

Copper flashing is one of the most durable of roof flashing materials. It is also one of the more expensive. Typical applications include chimney flashing, valley flashing on tile, wood shake, or slate roofs, as base, step and counter flashing at roof to sidewall intersections, or as exposed or concealed ridge and hip flashing. Fabricating and installing copper flashing is a learned skill at one time reserved for experienced craftsmen. Although the material is relatively soft and malleable, the techniques required to plan, cut,

shape, fabricate, and install complicated shapes take practice and patience. Copper can be fabricated into rigid, continuous custom shapes such as chimney crickets or other special configurations. For step flashing roof to sidewall applications, copper is available in standard 5 by 7-inches pieces. The Copper Development Association (CDA) and individual manufacturers have excellent manuals of recommended flashing details. The Association maintains that acid rain and the acid from red cedar shingles are not a problem when water is not allowed to stand and when cant strips are used to raise the shingles off the copper surface (see Fig. 1 for recommended details). The CDA recommends a minimum of 16 oz. plain or lead coated copper be used for valley flashings and 20 oz. when slate or tile is used for the roof material. Lead-coated copper is considered the premiere flashing material in northern and maritime climates because it combines copper's durability with lead's resistance to acid rain and characteristic of not staining adjacent materials.

ADVANTAGES: With proper installation, can be one of the most durable of all exterior building components. Soldering joints and intersections is relatively easy, allowing for the formation of permanent, three-dimensional, continuous shapes. Copper is a relatively pliant metal, is easy to form and work, and ages to a familiar protective green patina. At least one manufacturer, Revere Copper Products, Inc. makes a pre-patinated copper flashing for those unwilling to wait.

DISADVANTAGES: A relatively costly material. Labor costs are higher than other flashing materials. Unless roofs are properly detailed with overhangs and drip edges, rain water run-off from copper flashing can stain adjacent materials.

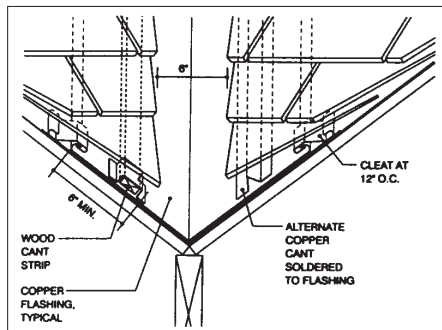

A. OPEN VALLEY

The detail shows a typical open flashing for a shingle or slate roof. Two different cants are illustrated. The cant strip can also be constructed as shown in Detail D. The shingles or slate must lap the flashing at least 6 inches.

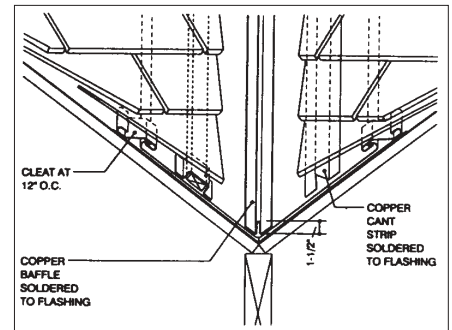

B. EQUAL SLOPES—UNEQUAL WATER FLOW

Where unequal water flow is expected, a baffle, 1 1/2 inches high, should be installed as shown to prevent water of higher velocity from forcing its way past the opposite edge of the valley flashing. The baffle can also be constructed as shown in Detail D.

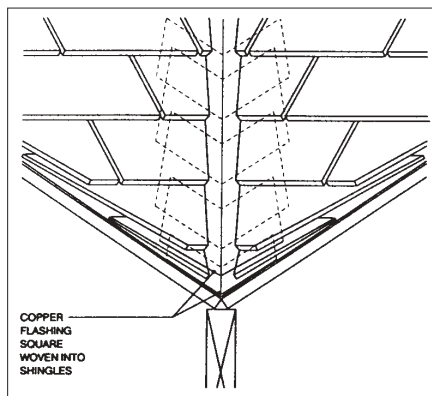

C. CLOSED VALLEY

Intersecting roofs using a closed valley must have the same slopes so that the shingle butts line up at the valley intersection. For roof pitches of 6" or more per foot the flashing extends at least 9" under the roof covering on each side. For roof pitches less than 6 inches per foot the flashing extends at least 12 inches.

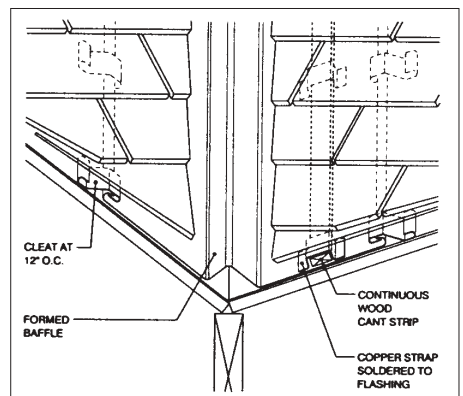

D. UNEQUAL SLOPES

This condition requires a baffle for the same reason as Detail B. it can be constructed as shown in either detail. This detail also shows a different cant strip. Other methods of raising the shingles away from the copper are shown in Details A and B.

FIGURE 1 A–D

3. INSTALL NEW ALUMINUM FLASHING.

Aluminum is a versatile and durable material appropriate for many roof flashing applications including chimney flashing, valley flashing, step flashing, base flashing, and counter flashing. Aluminum comes in rolls, sheets, and pre-formed shapes for specific applications such as drip edges. Aluminum comes in standard (mill) finish and factory paint finishes with white and bronze the most common. Aluminum may be left exposed to the elements with or without an applied finish, but anodized or painted material will last substantially longer. Coil stock 24 inches wide is available in about 30 standard colors for aluminum siding and trim cover applications. Mill or paint finished aluminum readily accepts field applied paint giving flexibility to desired finishes. Available in thickness from .016 to .032 inch. Thicker material will last longer in salty, acidic, or polluted environments. Unlike copper, field soldering of aluminum is not practical. In order to create water-tight seams, joints must be lapped, mechanically fastened, and caulked when necessary with high performance sealants. Fasten aluminum flashing to the framing with aluminum nails to avoid galvanic action between dissimilar materials (such as the aluminum flashing and steel nails), which can cause deterioration. **ADVANTAGES:** Aluminum is in the mid-cost range of metal flashing materials. A soft, workable material that forms easily and holds its shape well. Pre-formed aluminum drip edges and other related components speed installation and assure effective results.

DISADVANTAGES: Uncoated aluminum should not be placed in direct contact with concrete, mortar, or other cement-containing materials including fiber-cement siding and trim. The alkalinity of those materials will corrode bare aluminum. Creating water-tight joints and laps requires experience, skill, and high quality sealants.

4. INSTALL NEW GALVANIZED STEEL FLASHING.

Galvanized steel flashing is an economical material made by coating sheet steel with a layer of zinc alloy, either through electroplating or hot dipping. Typical gauges are 32 ga. (.010 inch) for roll product and 28 ga. (.015 inch) for pre-formed shapes. Roll flashing is available in widths up to 48 inches, usually in 50-foot lengths. Galvanized nails should be used to attach galvanized sheet steel to the frame structure, as dissimilar metal fasteners can cause corrosion. Contact with green lumber and treated lumber should be avoided, because the chemicals in treated lumber can react with the steel, and green lumber has high moisture levels which can lead to rusting. Attachments must be mechanical, such as crimping, or through the use of sealants, or both. Choose only high performing exterior grade sealants. Typical applications include valley flashing, base flashing, counter flashing, and chimney flashing. Common pre-formed shapes include “J” flashing for roof to side-wall intersections, drip edges, 90° bent base flashing, and shingle base flashing. These are normally available in 10-foot lengths.

ADVANTAGES: Lowest first cost of all metal flashing. A rigid material able to be formed into permanent three-dimensional shapes. Will accept paint in order to disguise the raw silver sheen at exposed applications. However, the thin oil coating on the steel must be removed before painting and primers designed for galvanized steel should be used. Preformed shapes and the 10-foot lengths make for quick, effective installation.

DISADVANTAGES: In its raw, un-painted form galvanized steel is the least durable of the metal flashing materials. In harsh environments, corrosion may occur in less than 15 years. Galvanized steel is a stiff relatively non-malleable material and is somewhat difficult to work with and form. Cannot be field soldered when forming custom fabrications as the required acid wash and heating process will damage the coating, exposing raw steel. Not cost-effective when used with long lasting roofing materials such as slate and tile.

5. INSTALL NEW GALVALUME™ SHEET METAL FLASHING.

Galvalume™ is a product similar to galvanized steel developed by Bethlehem Steel approximately 25 years ago. Where galvanized steel has a hot-dip coating of zinc, Galvalume™ is hot-dipped with an alloy consisting of 55 percent aluminum and 45 percent zinc by volume. By weight, aluminum makes up 80 percent of the coating. Galvalume™ is available in rolls 24 to 48 inches in width. Mechanical fasteners and sealants are typically required for field fabrications. Choose only high performing, exterior grade sealants. **ADVANTAGES:** An economical material similar in cost to galvanized steel, Galvalume™ is considerably more durable, with approximately twice the service life of galvanized. Galvalume™ readily accepts paint finishes, further increasing durability. A rigid material that can be formed into permanent three-dimensional shapes.

DISADVANTAGES: Galvalume™ should not be allowed to contact concrete foundations, masonry chimneys, or cement board siding, because these materials hold moisture which can lead to deterioration of the flashings. Contact with green lumber, treated lumber, copper, or lead should also be avoided, because of reasons mentioned in paragraph no. 4 above, and because of the contact of dissimilar metals which can lead to destructive galvanic action. Generally available in coil form only. Preformed shapes such as drip edges etc. not generally available. Stiffness and rigidity of the material makes site bracing and fabrication difficult; shop prefabrication is more practical. Galvalume™ should not be field soldered as the required acid wash and heat process will damage the coating, exposing raw steel.

6. INSTALL NEW STAINLESS STEEL FLASHING.

Stainless steel is a very durable flashing material particularly suited for harsh, corrosive, environments. It is available in rolls of 18 and 24-inch widths as well as sheet stock. Typical gauges are 18 and 24 ga. Typical applications include valley flashing, base flashing, and counter flashing. Stainless steel is generally not available in pre-formed shapes. Material costs for stainless steel sheet stock is roughly comparable with copper, making it a premium priced material. Stainless steel nails are recommended for installation.

ADVANTAGES: Of the most common roof flashing materials, stainless steel is the most durable and least affected by environmental corrosives such as acid rain or salt spray. Strong and rigid, stainless steel can be fabricated into complex shapes. It is a monolithic material which, when cut, maintains its corrosion resistance at the exposed edge. Stainless steel is not affected by contact with masonry mortar or concrete and can be field soldered using a special solder after acid etching of the surfaces to be adhered.

DISADVANTAGES: Although material costs for stainless steel flashing are comparable to copper, labor and installation are usually higher. Stainless steel is a very stiff, rigid material and is difficult, and often impractical, to bend and shape using a typical roofer's brake. Shop prefabrication is often required.

7. INSTALL RHEINZINK FLASHING.

Rheinzink is a metal flashing and roofing material comprising 99.99 percent high-grade zinc with 1 percent copper and 1 percent titanium alloys. Zinc has been used as flashing in Europe since the early 1800s; Rheinzink was introduced into the U.S. in 1992. It handles and performs much like copper, but develops a natural blue-grey, grey-green color through weathering, or it can be obtained pre-patinated. Available in sheet or roll form in .027 inch (24 ga.) and .031 inch (22 ga.) thickness for flashing use.

ADVANTAGES: Easily worked into complex shapes. Can be soldered. Manufacturer claims a lifespan of 100 years+ if properly detailed. Self-healing patina. Can be pre-patinated. Competitive in price with copper and less expensive than lead-coated copper. Inert material, will not leach chemicals and is recyclable. Will not stain adjacent materials. Extensive specification and detailing information available.

DISADVANTAGES: Underside of the metal requires ventilation to allow protective patination to develop. If the underside is allowed to stay damp, white rust and corrosion can reduce service life severely. Requires proper detailing - the underside must be protected by bituminous sheet material against: alkaline influence (e.g., fresh concrete or mortar); acid reacting antifreeze agents; harmful influence of wood preservative. Contact with copper should be avoided.

8. INSTALL NEW LEAD FLASHING.

Lead is one of the oldest flashing materials. It is durable and malleable, making it a favorite for use as cap flashings, in complex intersections, and with materials that have complicated profiles such as clay and concrete tiles. Available in rolls from 6 to 20 inches wide, typically in 2.5 pounds/square foot (0.0391") and 3 pound/square foot (0.0468 inch) weights. The use of lead has fallen off as a flashing material because of the concern over lead poisoning. Whereas lead can be used safely with appropriate handling techniques, precautions should be taken to avoid inhaling lead dust or fumes and to avoid hand-to-mouth transfer when eating or smoking. More detailed suggestions are available from the Lead Industries Association (LIA) (see Further Reading).

ADVANTAGES: Inert material relatively unaffected by salt and acid rain. Easily formed into complex shapes. Easily cut and soldered, long service life.

DISADVANTAGES: A relatively soft material that can tear, especially at right angle cuts. Can fatigue when fastened on all sides. Must be used with caution, requires special handling procedures.

9. INSTALL NEW ROLL ROOF FLASHING.

Mineral surfaced roll roofing is an economical flashing material for some roof valley installations. When installed in conjunction with asphalt roofing shingles, either three-tab or laminated, roll roofing valley flashing can be a quick, relatively durable installation with the ability to remain functional for 15 to 25 years depending on location, solar orientation, and the quality of the material and installation. The recommended installation involves two layers. The base layer, a minimum of 18 inches wide, is applied mineral surface down, and the surface layer, 36 inches minimum width, is installed mineral surface up (Fig. 2). The material comes in roll widths of 18 and 36 inches, with 36 inches being most common. Mineral surface roll roofing is available in colors to approximate asphalt shingle colors allowing for a more continuous appearance. The valleys may be installed continuously with no need for laps and seams as expansion and contraction length wise is not a large factor. Recommended fasteners are hot dipped galvanized or aluminum roofing nails with minimum 12 gauge shanks and $\frac{3}{8}$ inch heads. The roll roof valley flashing should be considered a part of the roofing system and should be replaced when routine re-roofing is required.

ADVANTAGES: An economical material which offers quick, simple installation, with the ability to last the life of the asphalt single roof system. No special skills or tools are required for installation.

DISADVANTAGES: Mineral surface roll roofing is appropriate for use in valleys only and with asphalt roofing products. Roll roofing will tend to shrink somewhat in width causing the material to lift from the base of the valley, leaving a void beneath it, which is susceptible to puncture (Fig. 3). Valley flashing of this type should never be walked on, and other impacts should be protected against. Roll roofing is not self sealing and is increasingly being replaced by ice and water barriers in colder climates.

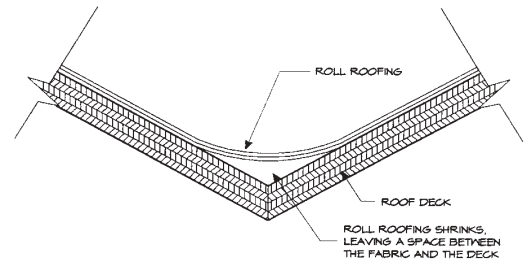
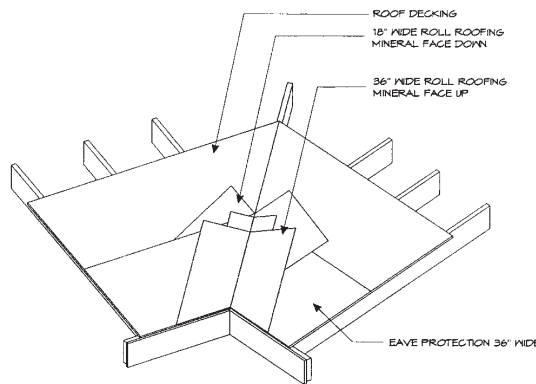

FIGURES 2, 3

ROLL ROOF VALLEY FLASHING

VALLEY CONSTRUCTED OF ROLL ROOFING

10. INSTALL NEW ICE AND WATER BARRIER MEMBRANE.

Ice and water barriers are relative newcomers to the world of flashing materials. Initially intended to combat ice damming at the eaves of sloped roofs and inhibit damage from wind-driven rain, they are now also used in conjunction with more traditional flashing materials as an additional line of defense against water entry at chimneys, valleys, skylights, and at other roof penetrations. Some manufacturers also recommend full surface coverage below the roof shingles at low slope applications. Ice and water barriers can be installed under all standard sloped roof materials. The materials are easy to work with even for the first time installer. Ice and water barriers are generally self adhering and applied directly to roof decking after the removal of the release paper. Manufacturers claim that they self seal around nail and fastener penetrations. The most common material compositions are modified bitumen with a granular surface, modified bitumen with a polyethylene surface, and rubberized asphalt with a polyethylene surface. Some membranes are available in roll form, for miscellaneous flashing uses. (See Section 5, *Underlayments and Moisture Barriers*).

ADVANTAGES: Relatively inexpensive protection against water penetration from ice damming. Can provide an additional measure of protection against wind-blown rain in high-wind areas.

DISADVANTAGES: Some types of ice and water barriers should not be installed in hot climates, which can cause heat degradation, or under dark roofs such as slate, because high summer roof temperatures (up to 180°F) can cause membrane to bleed. Ice and water barriers can conceal poor detailing and workmanship which may cause later problems. Can degrade when exposed to ultraviolet light.

FURTHER READING

Architectural Sheet Metal Manual, Sheet Metal and Air Conditioning Contractor's National Association (SMACNA).

Copper in Architecture, Copper Development Association, Inc.

Copper and Common Sense, Revere Copper Products, Inc., P.O. Box 300, Rome, NY 13442-0300.

Flashings and Weatherings, Lead Industries Association, www.leadinfo.com.

Gutters, Flashing and Roof Details video, Copper Development Association, Inc.

Old House Journal - Guide to Restoration, Old House Journal, 1992.

Rheinzink Roofing and Wall Cladding, Rheinzink Canada Ltd., www.rheinzink@rheinzink.com.

Roofing and Cladding, Lead Industries Association, www.leadinfo.com.

Roofing and Flashing Problems, Canada Mortgage and Housing Corporation, rev. 1995.

Steep Roofing Manual, National Roofing Contractors Association, 1996.

SSINA Designer Handbook and Standard Practices for: Stainless Steel Roofing, Fascias and Copings, Specialty Steel Industry of NA, February 1995.

Troubleshooting Guide to Residential Construction, Journal of Light Construction, 1997.

Working Safely With Sheet Lead, Lead Industries Association, www.leadinfo.com.

PRODUCT INFORMATION

Alcoa Building Products, Box 3900, Peoria, IL 61612; 800-962-6973, www.alcoahomes.com (aluminum building products).

Bethlehem Steel Corporation; Bethlehem, PA 18016; 800-352-5700, www.bethsteel.com/divisions/sparrow/spgalval.html (information on galvanized and Galvalume™ products).

H. Bixon & Co., P.O. Box 1198, New Haven, CT 06505; 203-777-7445 (supplier of sheet lead).

Heckman Industries, 405 Spruce Street, Mill Valley, CA 94941; 800-841-0066 (SBS rubberized asphalt in roll form).

Revere Copper Products, Inc., P.O. Box 300, Rome, NY 13442-0300; 800-950-1776, www.reverecopper.com (pre-patinated copper and other copper products).

Rheinzink Canada Ltd., 4560 Dawson Street, Burnaby, British Columbia, Canada V5C 4C; 604-291-6171; www.rheinzink@rheinzink.com (zinc flashing, roofing, siding and gutter systems).

Specialty Steel Industry of North America (SSINA), 3050 K Street, N.W., Washington, DC 20007; 800-982-0355; www.ssina.com (information on stainless steel).

Tamlyn and Sons; 10406 Cash Road, Stafford, TX 77477; 800-334-1676; www.tamlyn.com (roofing accessories).

W.R. Grace & Co., 62 Whittemore Ave., Cambridge, MA 02140; 800-444-6459; www.gcp-grace.com (ice and water barriers; see Section 5, *Underlayments and Moisture Barriers*, for a complete list of ice and water barrier manufacturers).

5

UNDERLAYMENTS AND MOISTURE BARRIERS

ESSENTIAL KNOWLEDGE

The primary purpose of roofing underlayments is to provide a secondary protective barrier beneath the roofing material. Typically this material has been 15# asphalt impregnated felt (now called No. 15) for lightweight material such as wood or asphalt shingles, and one or more layers of 30# (No. 30) asphalt-impregnated felt for heavier roofing material such as slate, clay, or concrete tiles. These materials are still in use. However, there is an increasing awareness among manufacturers and roofing consultants of the importance of reinforced underlayments in areas of severe snow or wind-driven rain. In hurricane-prone regions, it is recommended that roofing be designed with the assumption that the first layer will be breached.

Increasing numbers of manufacturers are recommending the use of “special applications” for severe conditions—what have generically become known as ice and water barriers. The pioneer in the development of these products in the early 1980s was W.R. Grace & Company. In the past several years most other asphalt roofing material manufacturers have introduced similar products. Local code requirements and manufacturers’ specifications should be consulted prior to selection of specific product.

TECHNIQUES, MATERIALS, TOOLS

1. REPLACE EXISTING ROOFING FELTS WITH NEW ASPHALT-SATURATED FELTS.

Asphalt-saturated roofing felt underlayments are made from recycled paper and wood products and are essentially the same as the felts used in built-up roofing, except that they are perforated. Typically installed in No. 15 or No. 30 weights (No. 15 weighs approximately 13 pounds/square, and No. 30 approximately twice that), roofing felts are installed from the bottom up in the same fashion as shingles so that water does not penetrate lower sheets. In locales with more severe weather, two layers of No. 15 or one layer of No. 30 felts are often recommended at building eaves 36" inside of the exterior wall to protect against ice damming. The felt edges are sealed with roofing mastic, with the second layer embedded in mastic. *The Residential Steep-Slope Roofing Material Guide*, produced by the National Roofing Contractors Association, (NRCA) offers detailed underlayment recommendations.

ADVANTAGES: No. 15 roofing felt, when properly applied, is usually satisfactory for lightweight roofing products in areas without severe exposure. Can be doubled up or No. 30 can be used to provide extra protection in areas of more severe exposure.

DISADVANTAGES: No. 15 felts can tear or buckle when subject to rain and wind prior to installation of roofing and may require replacement. Can be torn by roof traffic in the course of installing finish roofing. Thinner, not self-sealing and less water resistant than ice and water barriers. Will deteriorate over time.

2. REPLACE EXISTING ROOFING FELTS WITH NEW REINFORCED UNDERLAYMENT.

Reinforced roofing underlayments have been developed relatively recently that are less susceptible to tearing than conventional roofing felts. One product, Typar® 30, made of spunbonded polypropylene, has been

used for over 10 years in Canada and the U.S. as an underlayment for concrete and clay tile in place of No. 30 felt. The material, a moisture and water barrier, is also promoted as an underlayment for metal roofing and other roofing products.

ADVANTAGES: Stronger than roofing felts; tear resistant. Resists wind blow off. Will not rot, decay, or become brittle. Lightweight and easy to use. Water resistant. Pliable and flexible at low temperatures; conforms to irregularities. Can be used for reroofing. Low flame-spread rating.

DISADVANTAGES: A vapor barrier. Roof must be ventilated to avoid condensation problems. Not self-sealing. National code approvals pending; may not have local code approval.

3. REPLACE EXISTING ROOFING FELTS WITH NEW ICE AND WATER BARRIER.

Ice and water barriers are made with fiberglass and rubberized asphalt, typically styrene-butadiene-styrene (SBS) formulations. These materials are fairly recent developments and have high performance characteristics in terms of elongation, resistance to tear, and longevity. They come in one or two configurations: with a fine mineral granule or sand coating and with a top polyethylene sheet embossed to make it skid-resistant. They generally have a self-adhesive backing that adheres to the sheathing substrate. These products, particularly Grace's Ice and Water Shield®, have a strong following among users. Designed to be installed at the eaves a minimum of 36 inches inside of the exterior walls, ice and water barriers are also effective in providing extra protection under flashing at valleys as well as at overhangs, skylights, dormers, and vents and chimney flashing. Grace has recently developed a product called Vycor™ Ultra made of butyl rubber that is specifically designed to be used in high temperature applications such as the hot desert climates of the Southwest. Some roofing consultants caution against covering the entire roof, unless properly vented. The ice and water barrier can trap moisture in the attic space.

ADVANTAGES: A cost-effective, proven way of providing extra protection against potential leaks. When properly installed, reported to be effective against ice damming and wind-driven rain penetration under roofing materials. Self adhering; seals around nails. Resistant to cracking, drying out, or rot. Frequently used as a roofing membrane under low-slope roofs.

DISADVANTAGES: More costly than roofing felts. Can disguise poor workmanship which may lead to later problems. Ice and water barriers are vapor barriers and can cause condensation problems without proper attic or roof ventilation.

FURTHER READING

The NRCA Residential Steep-Roofing Manual, National Roofing Contractors Association, 1997.

Residential Steep-Slope Roofing Materials Guide, National Roofing Contractors Association, 1997.

PRODUCT INFORMATION

ALCO Shield Ice & Water Protector, ALCO-NVC, Inc., P.O. Box 14001, Detroit, MI 48214; 800-323-0029.

Arctic Seal #170, Herbert Malarkey Roofing Co., P.O. Box 17217, Portland, OR 97217; 530-283-1191.

Celoguard shingle underlayment, Celotex Corp., P.O. Box 31602, Tampa, FL 33631; 813-873-1700.

Eave & Valley Shield, Globe Building Materials, Inc., 2230 Indianapolis Blvd., Whiting, IN 46394; 219-473-4500.

Flashband, Andek Corp., P.O. Box 392, Moorestown, NJ 08057; 888-88ANDEK.

Grip Guard and Progard waterproofing membrane, BPCO, P.O. Box 3177, Wayne, NJ 07474-3177; 201-595-6695.

Miradri WIP 100 and 200, TC Miradri, 3500 Parkway Lane, Suite 500, Norcross, GA 30092; 770-447-6272.

Moisture Guard Plus, TAMKO Roofing Products, Inc., P.O. Box 1404, 220W 4th St., Joplin, MO 64801; 417-624-6644.

Stormaster DG Ice & Water Protection, Atlas Roofing Corp., 1775 The Exchange #160, Atlanta, GA 30339; 770-952-3170.

Stormshield/Black Diamond Base Sheet, GS Roofing Products Co., 5525 MacArthur Boulevard, Suite 900, Irving, TX 75038; 972-580-5600; www.gsroof.com.

Typar® 30, Twinpak, Inc., 369 Elgin Street, Branford, Ontario N3T 5V6, Canada.

Vycor™ Ice and Water Shield® and Vycor™ Ultra, W.R. Grace & Company, 62 Whittemore Avenue, Cambridge, MA 02140; 800-444-6459; www.gcp-grace.com.

Weather Rock polyethylene surface and granulated surface, Owens Corning, One Owens Corning Parkway, Toledo, OH 43659; 419-248-8000.

Weather Watch and Stormguard waterproof underlayment, GAF Materials Corp., 1361 Alps Road, Wayne, NJ 07470; 973-628-3000.

Winterguard™, Certainteed Corp., Roofing Products Group, P.O. Box 1100, 1400 Union Meeting Road, Blue Bell, PA 19422; 800-322-3060.

6

INSULATION

ESSENTIAL KNOWLEDGE

Insulation is one element in a tightly knit construction system intended to improve indoor comfort and reduce energy consumption. Insulation should never be applied without considering its effect on other aspects of construction. Some factors to consider when evaluating roof and ceiling insulation are density and compressibility, air leakage, moisture control and fire safety.

Each type of insulation has a density at which its R-value per inch is greatest, but reaching this density is not cost-effective. For 3½-inch-thick fiberglass batts, an R-13 batt contains 40 percent more material, and an R-15 batt 180 percent more material, than an R-11 batt (Fig. 1). Achieving the maximum possible R-value for a 3½-inch fiberglass batt requires packing in the equivalent of eight R-11 batts.

Some blown-in insulation tends to settle, reducing its R-value. To achieve a desired overall R-value

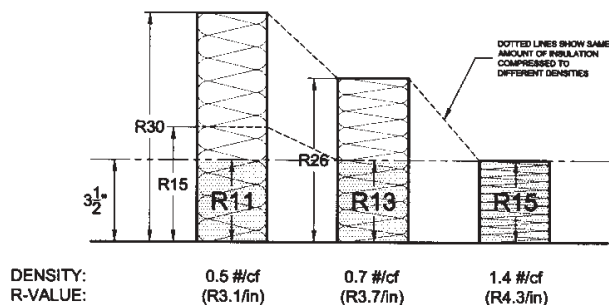

FIGURE 1

TYPICAL FIBERGLASS BATT DENSITIES & R-VALUES

for blown-in insulation, specify the R-value or depth as measured after settlement. The required bag count per net 1,000 sf to achieve a given settled R-value is listed on the bag, or can be obtained from the manufacturer. Monitoring installed bag count is a convenient way to insure a good installation.

Air leakage can bypass roof and ceiling insulation and create a risk of condensation. Air leakage into attics and through cathedral ceilings typically occurs around vent piping, ductwork, wiring, bath fans, skylights, down lights, attic stairs, all of which should be carefully sealed or gasketed. Avoid down lights in attic ceilings; if present, they should be of the IC (Insulation Contact) type, and ideally be of the more expensive airtight design. Interior finishes with many joints, such as tongue-and-groove wood decking, can also contribute to air leakage in a cathedral ceiling; an air barrier is recommended behind the planking.

Because the most commonly used roofing material, asphalt shingles, forms an airtight and vapor-tight surface, moist air can accumulate in an unvented attic or within a cathedral ceiling during cold weather. One way to prevent this problem is to install a vapor retarder at the ceiling, in conjunction with careful air sealing, and thereby inhibit moisture from leaking into the attic or ceiling assembly.

Since vapor retarders and gap sealing are seldom perfect, an additional precaution to prevent condensation, usually required by code, is to provide ventilation into the attic or between the insulation and roof surface in a cathedral ceiling. This is most commonly achieved using “ventilation baffles” — U-shaped channels made from polystyrene foam or cardboard, stapled to the underside of the roof sheathing (Figs. 2 and 3). These baffles ensure a space for ventilation air between the insulation and the roof sheathing, and are effective at controlling condensation even when they don’t communicate with eave or

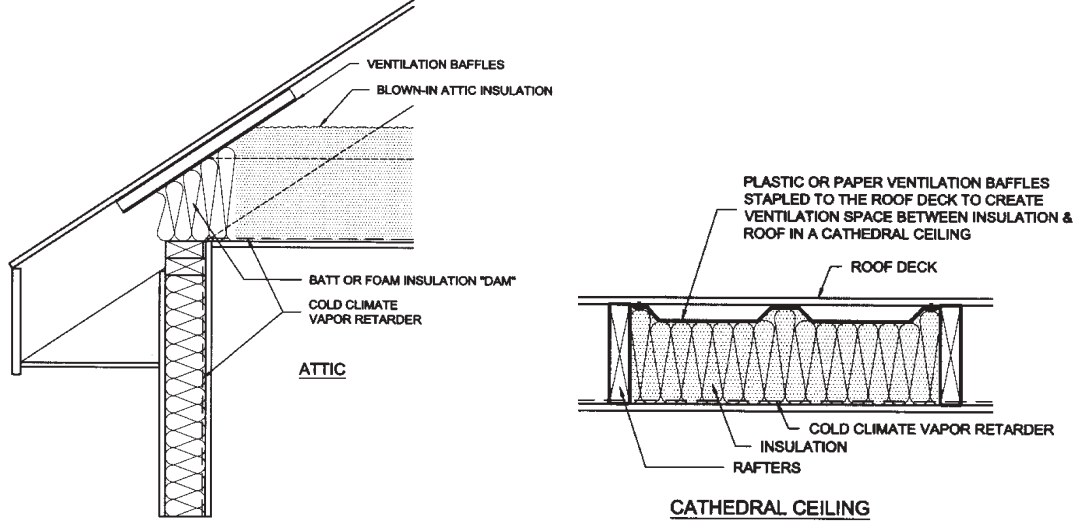

FIGURES 2,3

TYPICAL VENTILATION BAFFLES

ridge vents (as long as a ceiling vapor retarder is used). In addition, if ventilation is required between insulation and roofing to protect the warranty on roofing, roofing paper, or roof decking, ventilation baffles can provide this ventilation. The need for such ventilation is being studied.

Some sort of air barrier and insulation is desirable around a flue or chimney where it penetrates a floor or roof, but the material used must be rated to resist high temperatures. While fiberglass is non-combustible, at suitably high temperatures the binder holding the fibers together outgasses, and the fibers fall apart. For this reason, mineral wool or other “fire-safing” material made for the purpose should be used to seal around high-temperature surfaces.

TECHNIQUES, MATERIALS, TOOLS

Of the innumerable possible combinations of insulating materials and roof and ceiling configurations, the following list covers those in common use and the uncommon systems that are recommended.

1. INSTALL BATT INSULATION AT CEILING LEVEL.

Where the insulation is deeper than the ceiling framing members, a gap-free installation requires two layers of batts: a lower one the depth of the ceiling joist or bottom truss chord, plus a continuous upper layer (Fig. 4). Unfaced fiberglass batts installed from below in new construction may need to be temporarily supported. This is best done with fishing line stretched against the ceiling framing and stapled in place. Faced batts, face- or inset-stapled from below in new construction, or installed from above over existing ceilings, can create a partial cold-weather vapor retarder, as can special “vapor barrier” paint or primer

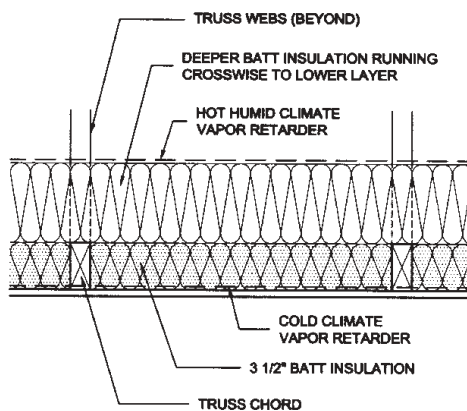

FIGURE 4

TWO LAYER BATT APPLICATION AT ATTIC

applied to the finished ceiling. To create a complete cold-weather vapor retarder and air barrier, a membrane must be installed against the framing in new construction or below the existing ceiling, and covered with new ceiling material. In hot-humid climates, a vapor retarder should never be installed at ceiling level, but one is desirable on the attic side of the insulation to inhibit condensation at the ceiling, especially in tightly sealed homes. Applying fire-retardant-faced batts (used in commercial projects) facing up with all joints taped may be a feasible way to achieve an attic-side vapor-retarder.

ADVANTAGES: Avoids the special equipment needed to blow in loose-fill insulation. Does not settle. Avoids cold-weather convective loss in low-density blown fiberglass. Faced batts form a partial vapor retarder when properly installed.

DISADVANTAGES: Batt insulation depends for its effectiveness upon careful installation to avoid gaps and consequent convective losses. Exposed fiberglass can be irritating if touched or inhaled. Typically more costly than blown-in insulation except for small areas.

2. INSTALL LOOSE-FILL INSULATION AT CEILING LEVEL.

Cellulose, mineral wool (either slag wool or rock wool) and fiberglass can be blown onto a ceiling from above. Small blowers can be rented by the day for rehab projects, or the work can be done by a specialty contractor. Cellulose and mineral wool installations typically are less costly than fiberglass, but prices vary by locality. Care must be taken to keep insulation 3 inches away from down light cans that are not of the IC (zero-clearance) type (Fig. 5). At eaves, ventilation baffles or other measures are required to prevent the insulation from blocking required ventilation (Fig. 2). If an attic floor is desired, its support framing must be deep enough for the desired thickness of insulation. Higher density is more effective at inhibiting air circulation through the insulation. Cellulose can be blown up to 2 pounds per cubic foot (pcf) density,

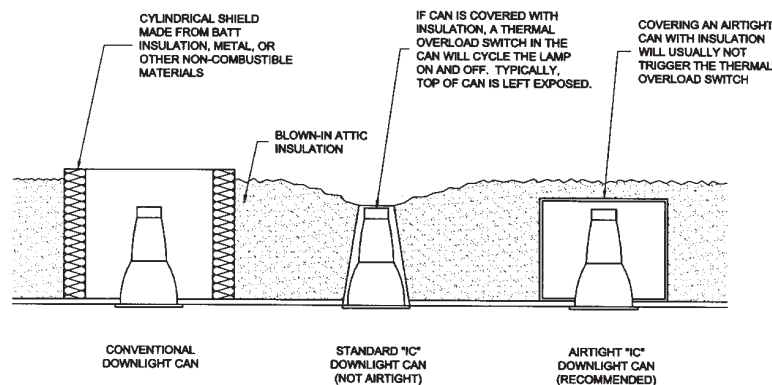

FIGURE 5

TWO LAYER BATT APPLICATION AT ATTIC

mineral wool up to 1.5 pcf, and fiberglass up to 1 pcf. Weight limits for gypsum board ceilings are: 1.3 pounds per square foot (psf) for 1/2-inch board supported every 24 inches; 2.2 psf for 5/8-inch board supported every 24 inches; 2.2 psf for 1/2-inch board supported every 16 inches. During very cold weather, warm air can circulate by convection within low-density fiberglass (1/2 pcf), reducing its R-value. This effect can be inhibited with an added layer of batts, denser loose-fill material or a layer of blown-in blanket system (BIBS) insulation; check with local energy codes for requirements. For small projects, vermiculite and perlite loose-fill insulation is available for hand pouring if rental blowing equipment is unavailable. No loose fill material creates a vapor retarder or air barrier.

ADVANTAGES: Can be blown-in from one or more central points. Variable in thickness; usually the least costly form of attic insulation. Forms a complete blanket of insulation, filling irregular cavities.

DISADVANTAGES: Does not form a vapor retarder or an effective air barrier. Some lower-density insulation will settle, reducing its R-value accordingly. Low-density blown fiberglass loses some effectiveness during very cold weather because of convection within the insulation.

3. INSTALL BATT INSULATION AT ROOF LEVEL IN CATHEDRAL CEILINGS.

Cathedral ceilings can be insulated with fiberglass batts, which are typically installed against ventilation baffles (Fig. 3). Faced batts provide a partial vapor retarder if the flanges are face- or inset-stapled to the framing. Unfaced batts need a separate (preferably) 6-mil polyethylene vapor retarder to hold the batts in place and provide a continuous vapor retarder. Stretched and stapled fishing line can be used to temporarily support thin (R-11 through R-19) batts, which are cut 1 inch narrower than thicker batts and which are less likely to stay in place by friction. At unfinished insulated attic ceilings requiring a vapor retarder, foil-faced or kraft-paper-faced batts cannot be left exposed to the attic space; use fire-retardant-faced batts, or (if allowed by local code) poly-faced encapsulated batts or a separate poly vapor retarder. **ADVANTAGES:** Least costly way to insulate an open rafter space. Faced batts create a partial vapor retarder when properly installed. Properly installed insulation at roof level saves energy by keeping all ductwork and down lights within the conditioned envelope.

DISADVANTAGES: Depends for its effectiveness upon careful installation to avoid gaps and consequent convective losses. Requires a finished ceiling.

4. INSTALL ENCAPSULATED FIBERGLASS INSULATION.

Fiberglass insulation is available in rolls or batts, encapsulated with kraft paper or plastic to reduce mechanical irritation to installers. These can be used in any installation where batts are appropriate. One face is extended to form attachment tabs. The faces on sound control batts do not have a vapor retarder; some underfloor batts are vapor retardant on all sides other than the flanged face, and could be useful as cold-climate attic insulation installed from above; some exterior wall batts have a polyethylene vapor retarder on the flange side. Some encapsulated batts have a Class A fire-rating and can be left exposed if allowed by local codes. Owens Corning markets Miraflex, made from loose, virtually itch-free glass fibers with no binder, contained in a plastic sleeve. Cutting encapsulated batts around obstructions is possible, but exposes the fiberglass.

ADVANTAGES: Ideal for rehab contractors. Can be left exposed (check local codes). Flange-attached with or without a vapor retarder on some products. Unique underfloor product with vapor retarder opposite the flanged face. Fibers released from cut Miraflex can fill in small voids around obstructions.

DISADVANTAGES: More expensive. Cutting encapsulated batts exposes the fiberglass, and cutting Miraflex releases the fibers.

5. INSTALL BLOWN-IN LOOSE-FILL INSULATION INTO CLOSED RAFTER SPACES AT ROOF LEVEL.

Loose-fill insulation (fiberglass, cellulose, or mineral wool) can be blown into closed rafter spaces in cathedral ceilings through openings formed by drilling holes through the interior finish, or by removing strips of interior finish, at the upper and lower ends of each rafter space. If roof ventilation is required by code or to protect roof material warranties, the interior finish must be removed to install ventilation baffles, resulting in an open joist cavity (see Section 3 above). Careful installation is required because material can bridge over wiring and other obstructions, causing voids and later settlement. At least a moderate amount of pressure is required to produce sufficient density to inhibit settlement. Fiberglass is typically blown into a cavity at a density of about 1.5 pcf without creating excess pressure on finishes. In a “dense-pack” installation of cellulose, dry material is applied at high velocity through a narrow tube inserted through a single hole at the top and extending to the bottom of the cavity. The tube is gradually withdrawn, compacting the material to a density of 3 to 3-1/2 pcf. Stabilized™ cellulose includes an adhesive, and Fiberized™ cellulose is made in strands instead of chunks; both processes are claimed to inhibit or prevent settlement. Insulation packed into and filling wall cavities suppresses air movement within the cavity. **ADVANTAGES:** If the cavities are completely filled under sufficient pressure, provides superior insulating performance without settlement. Properly installed insulation at roof level saves energy by keeping all ductwork and down lights within the conditioned envelope.

DISADVANTAGES: Some types of installation may leave voids and/or settle after installation. Blown-in materials do not form a vapor retarder, and form only a partial air barrier. Very difficult to ventilate.

6. INSTALL BLOWN-IN OR SPRAYED-ON INSULATION INTO OPEN RAFTER SPACES AT ROOF LEVEL.

An inexpensive material can be applied as a membrane over open rafters to form “see-through” cavities, within which any blown-in insulation can be applied under moderate pressure. In Ark-Seal’s “Blow-In-Blanket System,” fiberglass mixed with some water and adhesive is blown through slits cut in a tightly stretched nylon netting. In Par-Pac’s Dry-Pac system, dry cellulose is blown at 3 pcf density into a cavity closed by a reinforced polyethylene vapor retarder. The material is installed from the bottom up to minimize settlement. All such installations will cause the membrane to bulge out; make sure this bellying does not interfere with drywall installation. Various types of polyurethane- and polyisocyanurate-based insulations, such as Icynene, can also be spray-applied into the rafter cavities of cathedral ceilings. A thin layer of such material can form an air-barrier skin, over which cheaper material can be placed. Excess material must be scraped off, and windows and electrical devices protected or cleaned. If roof ventilation is required by code or to protect roof material warranties, ventilation baffles must be installed.

ADVANTAGES: Fills the cavities without settling. Visual inspection is possible to insure filled cavities. Properly installed insulation at roof level saves energy by keeping all ductwork and down lights within the conditioned envelope.

DISADVANTAGES: Bellying of the interior membrane may interfere with drywall installation. Sprayed-on foam products are more expensive than batt or loose-fill installations, and are messy processes, requiring cleanup and protection.

7. INSTALL RIGID INSULATION BELOW THE ROOF STRUCTURE.

To increase the R-value of a cathedral ceiling, it may be more cost-effective to add a layer of rigid foam insulation under the rafters than to deepen the rafters and add more cavity insulation. In most climates, it pays to add foam to 2 by 6 or shallower rafters and not to add foam to 2 by 10 or deeper rafters, with 2 by 8 rafters an in-between case. If the roof framing is steel, it is necessary to add a layer of insulation between the framing and the ceiling to prevent interior condensation and ghosting in cold climates, and to minimize condensation on the framing in hot-humid climates. An added layer of foam can improve the R-value of the assembly by more than the R-value of the foam, since it suppresses cold bridges through framing members. In cold climates, foil-faced rigid insulation can provide a useful vapor retarder. Do not use a vapor-retarding foam in hot-humid climates, as any retarder should be on the warm side of the insulation.

ADVANTAGES: A useful way to raise the R-value of a cathedral ceiling; an essential adjunct to normal insulation at steel framing. If the insulation panel is foil-faced, it can create an excellent vapor retarder in cold climates. Properly installed insulation at roof level saves energy by keeping all ductwork and down lights within the conditioned envelope.

DISADVANTAGES: Usually not cost-effective relative to deeper framing in new construction. Foam plastics cannot be left exposed in an attic or facing living space.

8. INSTALL RIGID INSULATION ABOVE THE ROOF STRUCTURE.

Rigid insulation above the roof structure is the only practical way to insulate an exposed plank-and-beam roof, and can be used under low-slope Built-up Roof (BUR) membranes, Modified Bitumen (MB) membranes, and flexible membrane systems (single-ply roofing systems). Pre-formed insulation boards provide resistance to heat flow through roof decks and serve as a base for the roofing membrane. Most types of rigid insulation can be adhered to roof decks with hot or cold asphalt or adhesives, can be mechanically attached, and in some cases, can be ballasted with gravel or crushed stone. Industry associations recommend that a fiberboard overlay or venting base sheet be used over foam products when used under hot-applied BUR or MB systems. Roofing insulation should not be applied over wet roof decks or decks with moisture in the existing membrane or insulation. When multiple layers are used (which is usually recommended) the joints of the top layer should be staggered and offset from the layer below. For specific recommendations, refer to the relevant industry association's guidelines or individual roofing product manufacturer's specifications (see Further Reading and Product Information). A variety of roof insulation products is available:

■ **Polyisocyanurate (ISO):** Composed of a plastic foam manufactured from the reaction of an isocyanate and a polyol formed into a board with a glass reinforced cellulose felt face sheet on both sides. ISO is available in varying sizes, thicknesses from 1 to 5 inches, and a nominal density of 2 pcf. It is available tapered to provide the necessary slope for drainage. ISO is the dominant roofing insulation because it has high thermal resistance.

■ **Extruded Polystyrene (XPS):** Formed by the expansion of a blowing agent in a plastic (polystyrene) polymer in a heated die extruder; available in a variety of sizes, thicknesses and in densities of 1.5 to 3.0 pcf. XPS is relatively unaffected by occasional immersion in water and can be used in a "Protected Membrane Roof" (PMR) (at one time referred to as an IRMA roof) in which the insulation is above the membrane, thereby reducing thermal shock. PMR systems require gravel or crushed rock ballast. XPS should not be installed with coal tar pitch (except in protected membrane applications) or solvent-based materials.

■ **Molded Expanded Polystyrene (EPS):** Formed in a large mold by the expansion of a blowing agent and plastic (polystyrene) polymer under heat and pressure typically cut by hot wires into a variety of sizes and thicknesses in densities of 1.0 to 2.0 pcf. Less costly than XPS or ISO. Do not install with coal tar pitch or highly solvent-extended mastics.

■ **Fiberglass Insulation:** Composed of fiberglass bonded with resin with a glass reinforced asphalt and kraft paper facer on the top side. Has stable thermal value and is dimensionally stable. Available in a variety of sizes, thicknesses typically from 3/4 to 3 inches. Fibrous glass roof insulation is an excellent recover board due to its ability to conform to irregularities.

■ **Fiberboard Insulation:** Composed of wood, cellulosic, or vegetable fibers bonded together to form tough, rigid insulating panels suitable for use as a general purpose roof insulation under BUR and MBM roofing systems and over foam insulation products. Available in a variety of sizes and thickness from 1/2" to 2 inches. Has R factors considerably below foam insulating products. Boards can be adversely affected by moisture and require a venting base sheet be used to separate boards from existing roof surfaces when the likelihood of moisture is present.

■ **Expanded Perlite:** A rigid board composed of expanded siliceous ore particles, cellulose fibers, starch and other synthetic binders. Has been used as a base for low slope roofing systems since 1950. Fire and water-resistant. Excellent base for bituminous roofing materials. Constant insulating value. Available in thicknesses from 1/2 to 4 inches and a variety of sizes. Available in tapered form. Often used for crickets, saddles, cant strips, and tapered edge strips.

■ **Cellular Glass:** A rigid, high density board material composed of glass foam blown with hydrogen sulfide. Available in sizes 2 to 4 feet in length and 1 to 4 inches in thickness.

■ **Phenolic Foam:** This product performed unsatisfactorily and is no longer produced in the United States

■ **Composite Insulation Boards:** Composed of perlite fiberboard or oriented strand board OSB typically laminated to ISO. Adds protective and/or nail base material to ISO products.

9. INSTALL A RADIANT BARRIER.

While radiant barriers and coatings are commonplace in high-temperature industrial applications (typically 500° F or more), they are marginally effective at ordinary temperatures. To be cost-effective in building applications, they must have a very low incremental cost (approximately from 2 to 10 cents/sf, depending on the application). Radiant barriers are most effective at roof level, facing down toward the attic. These can be sheets of foil-faced plastic draped over the rafters before sheathing or stapled to the underside of existing rafters. Louisiana-Pacific makes TechShield™ foil-faced OSB sheathing (formerly KoolPly). Because of elevated daytime temperatures, confirm that warranties on the sheathing, building paper and roofing remain valid when placed above a radiant barrier. A new form of radiant barrier is Radiance paint, which contains aluminum dust.

ADVANTAGES: Down-looking radiant barriers at roof level may be cost-effective when air conditioning ductwork is located in the attic.

DISADVANTAGES: Marginally cost-effective at ordinary temperatures. Not effective in cold climates, except possibly Radiance paint.

10. INSTALL A STRUCTURAL INSULATED PANEL ROOF.

Rigid foam insulation adhered to structural skins can create a structural insulated panel (SIP). SIPs provide a combination of structure and insulation. Depending upon the configuration, the panels may or may not be supported by beams, trusses, or purlins. Very tight joints are crucial, since a small amount of air leakage through a joint is guaranteed to create destructive condensation at the most critical structural point. SIPs are typically better-insulated and cheaper than structural decking with foam insulation above it. If ventilation under the roofing is required by code or to protect the roofing warranty, SIPs can be made with ventilation cavities at extra cost.

ADVANTAGES: A high-R roof can be achieved with an integrated structural product. Properly installed insulation at roof level saves energy by keeping all ductwork and down lights within the conditioned envelope.

DISADVANTAGES: Currently more costly than ordinary framing. Requires careful air-sealing at all joints. Often requires subsidiary support structure. Ventilation between roofing and the insulation adds cost.

FURTHER READING

ASHRAE 1997 Handbook of Fundamentals, Inch-Pound Edition, Chapter 22: Thermal and Moisture Control in Insulated Assemblies—Fundamentals; Chapter 23: Thermal and Moisture Control in Insulated Assemblies—Applications; Chapter 24: Thermal and Water Vapor Transmission Data, American Society of Heating, Refrigerating and Air-Conditioning Engineers, Inc., Atlanta, GA; 404-636-8400. Website: <http://www.ashrae.org>.

Cushman, Ted, "Fiberglass vs. Cellulose: Making the Choice," *Journal of Light Construction*, September 1995, pp 27-31, Builderburg Partners, Ltd., Washington, DC; 800-552-1951.

Energy Source® Catalog, Iris Communications, Inc.; 800-346-0104.

Energy Star Fact Sheets; Builder Guides; U.S. Environmental Protection Agency (EPA), Atmospheric Pollution Prevention Division; 888-STAR-YES.

Home Energy's Consumer Guide to Insulation, website: <http://www.homeenergy.org/eehem/96/9609insulation.html>.

Residential Energy Efficiency Database (REED), Information Technology Specialists, Inc.; 403-892-3594 website: <http://139.142.36.88/reed/index.htm>.

Sawnee Energy Library, website:

<http://www.energydepot.com/sawnee/library/library.cfm>.

Southface Energy Institute, P.O. Box 5506, Atlanta, GA 30307; 404-525-7657.

U.S. Department of Energy (DOE) Energy Efficiency and Renewable Energy Clearing House (EREC); 800-363-3732. Email: doe.erec@nclinc.com. Website: <http://erecbbs.nclinc.com>.

Insulation Fact Sheet, August 1997, Document DOE/CE-0180

Loose-Fill Insulations, May, 1995, Document DOE/GO-10095-060

Wilson, Alex, "Insulation Materials: Environmental Comparisons;" *Environmental Building News*, Volume 4, Number 1, January/February 1995, West River Communications, Inc., Brattleboro, VT; 802-257-7300.

Wilson, Alex, "Insulation Comes of Age," *Fine Homebuilding*, February/March 1996, No. 100, The Taunton Press, Inc., Newtown, CT; 800-283-7252.

PRODUCT INFORMATION

BATT, SPRAY-ON AND LOOSE FILL INSULATION

American Rockwool, Inc., P.O. Box 880, Spring Hope, NC 27882; 919-478-5111.
Ark-Seal International, 2190 South Kalamath, Denver, CO 80223; 800-525-8992.
Building Products Division, The Celotex Corporation, P.O. Box 31602, Tampa, FL 33631; 813-873-4000.
CertainTeed Corporation, 750 East Swedesford Road, Valley Forge, PA 19482; 800-523-7844.
GreenStone Industries Inc., 6500 Rock Spring Drive, Suite 400, Bethesda, MD 20817; 888-592-7684.
Icynene Inc., 376 Watline Avenue, Mississauga, ON L4Z 1X2, Canada; 800-946-7325.
International Cellulose Corp., 12315 Robin Boulevard, Houston, TX 77245-0006; 800-444-1252.
Johns Manville Corporation (formerly Schuller International Inc.), 717 17th Street, Denver, CO 80202; or P.O. Box 5108, Denver, CO 80217-5108; 800-654-3103.
Knauf Fiber Glass, 240 Elizabeth Street, Shelbyville, IN 46176; 800-200-0802.
Owens Corning, One Owens Corning Parkway, Toledo, OH 43659; 800-354-PINK or 800-GET-PINK.
Rock Wool Manufacturing Co., 203 North Seventh Street, Leeds, AL 35094; 205-699-6121.
Sloss Industries Corporation, 3500 35th Avenue North, Birmingham, AL 35207; 205-808-7803.
U.S. Fiber, Inc., 905 East Martin Luther King Dr., Suite 400, Tarpon Springs, FL 34689; 800-666-4824.
Western Fiberglass Group, 6955 Union Park Center, Suite 580, Midvale, UT 84047; 801-562-9558.

STRUCTURAL INSULATED PANELS

Structural Insulated Panel Association, 1511 K Street NW, Suite 600, Washington D.C. 20005; 202-347-7800; Email sipadc@aol.com.

RIGID FOAM INSULATION

Celotex Building Products, P.O. Box 31602, Tampa, FL 33631-3602; 813-873-4230.
Dow Chemical Company, Styrofoam Brand Products, 2020 Willard H. Dow Center, Midland, MI 48674; 800-258-2436.
Johns Manville Corporation (formerly Schuller International Inc.), 717 17th Street, Denver, CO 80202; or P.O. Box 5108, Denver, CO 80217-5108; 800-654-3103.
Owens Corning, One Owens Corning Parkway, Toledo, OH 43659; 800-354-PINK or 800-GET-PINK.
Tenneco Building Products, 2907 Log Cabin Dr., Smyrna, GA 30080; 800-241-4402.

RIGID FOAM COMPOSITE NAILBASE PANELS

Celotex Building Products, P.O. Box 31602, Tampa, FL 33631-3602; 813-873-4230.
Cornell Corporation, P.O. Box 338, Cornell, WI 54732; 715-239-6411.
Homasote Company, Box 7240, West Trenton, NJ 08628; 800-257-9491.
Johns Manville Corporation (formerly Schuller International Inc.), 717 17th St., Denver, CO 80202; or P.O. Box 5108, Denver, CO 80217-5108; 800-654-3103.

RADIANT BARRIER PRODUCTS

Radiance™ Low-E interior paint, ChemRex, 889 Valley Park Drive, Shakopee, MN 55379; 800-433-9517.
Super-R™ radiant barriers, Innovative Insulation Inc., 6200 W. Pioneer Parkway, Arlington, TX 76013; 800-825-0123; Email: insulation@earthlink.net.
TechShield™, Louisiana-Pacific Corp., 111 SW Fifth Avenue, Portland, OR 97204; 800-648-6893.

WOOD SHINGLES & SHAKES

ESSENTIAL KNOWLEDGE

Wood shingles and shakes (thicker, more rustic versions of shingles) have been used for roofing in this country for more than 300 years. Originating in England, the technique of making shingles and shakes involved the radial cutting of large trees, originally including oak, white pine, hemlock, and other softwoods. Today, shingles and shakes are milled largely in Canada and are made mostly from western red cedar, eastern white cedar, and Alaskan yellow cedar. Pressure-preservative-treated southern yellow pine is also used for shakes. Western red cedar weathers a darker gray than eastern white cedar or Alaskan yellow cedar. One or two mills make redwood shingles, but they are not as popular as cedar because they weather considerably darker (although they perform well). Warranted by the members of the Cedar Shake and Shingle Bureau (CSSB) against material defects for a minimum of 20 years, wood shingles and shakes can last longer in colder climates, depending on the building site, local climate, shingle grade, and installation. Wood shingles and shakes perform less well in hot, arid climates. Pressure-preservative-treated (CCA) shingles perform better than untreated shingles in hot, humid, southeastern states. In areas where solid sheathing is required for fire, seismic, high wind, or snow conditions, direct attachment to solid sheathing is acceptable, especially if the shakes or shingles are pressure treated with preservatives or pressure impregnated with fire-retardant polymers.

Shingles and shakes can be applied over existing roofing materials with the use of furring strips, but the preferred application is directly over sheathing. For optimum service life, CSSB recommends that cedar shakes and shingles be attached over spaced sheathing such as 1 by 6 boards (Fig. 1 and 2) or horizontal furring strips over solid sheathing or insulating sheathing (Fig. 3). Alternatively, shingles can be installed over a plastic mesh product such as Cedar Breather™. The use of spaced sheathing in combination with soffit and ridge vents will allow the shingles and shakes to “breathe” and will reduce excessive moisture. Horizontal furring will also allow for air circulation under the shingles and shakes, prolonging their life.

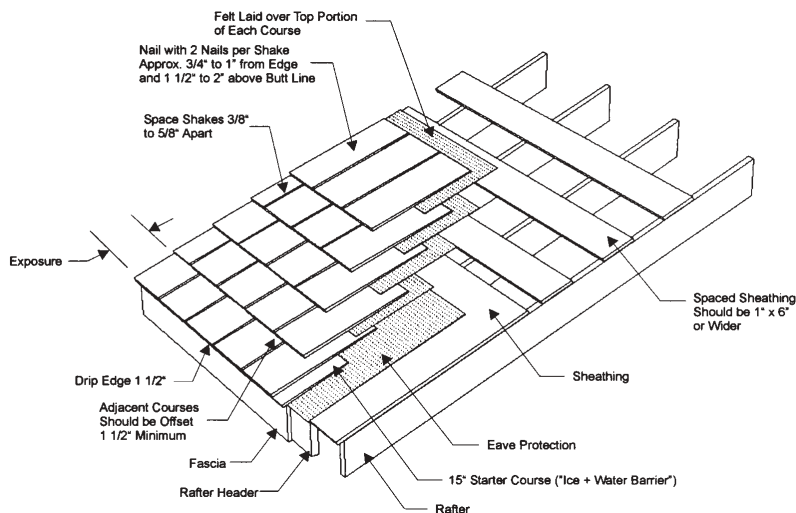

FIGURE 1

SHAKE APPLICATION

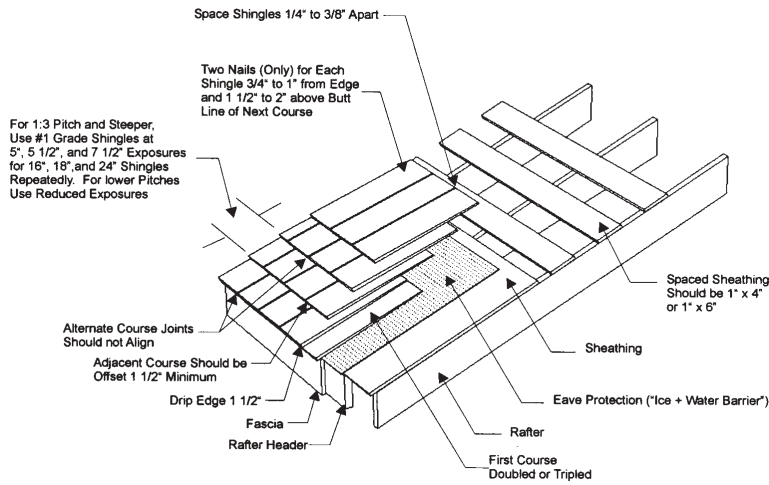

FIGURE 2

SHINGLE APPLICATION

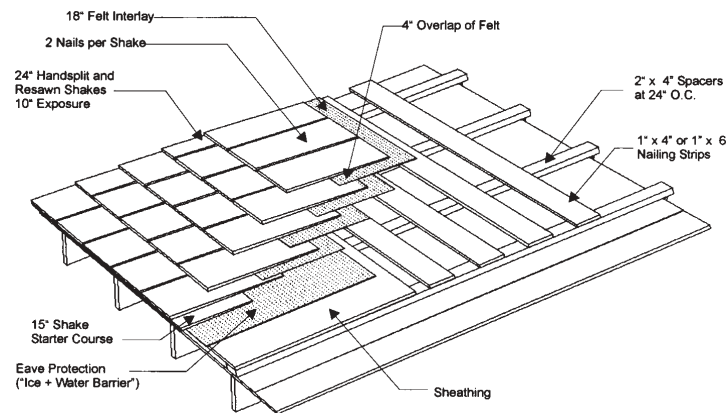

FIGURE 3

APPLICATION OVER SOLID OR INSULATED SHEATHING

Wood shingles generally perform better in high wind locations than some other roof coverings such as asphalt shingles, because they are rigid and do not curl. Testing with normal two-nail fastenings show resistance to 120+ mph winds. Under severe conditions, heavier than normal roofing felt underlayment, such as two layers of 15# felt, one layer of 30# felt, or a self-sealing reinforced fabric such as an ice and water barrier, is recommended at eaves, roof protrusions, valleys, and other critical areas.

TECHNIQUES, MATERIALS, TOOLS

1. REPAIR EXISTING CEDAR SHINGLES.

It is relatively easy to judge the condition of wood shingles and shakes, although alternate exposures of the roof may wear differently. Very mossy shingles can sometimes be cleaned of moss or lichen with the use of pressure washing; however, pressure washing can erode shingles. The CSSB has a list of products and techniques that can assist in shingle maintenance. When shingles or shakes begin to split and curl excessively, or become soft, spongy, or crumbly, they should be replaced. Individual cracked, split, or defective shingles or shakes are easily removed and replaced using simple tools such as prybars.

ADVANTAGES: Repairs are easy to make and are cost-effective over small areas.

DISADVANTAGES: If large areas need replacement, or if serious leaks develop, postponing replacement can cause damage to the building's structural elements or finishes.

2. INSTALL NEW CEDAR SHINGLES.

Cedar shingles are available in four grades. No. 1 BLUE LABEL with 100% heartwood, 100% clear, and 100% edge (vertical) grain. This recommended grade will have the longest life and is least likely to curl and split due to the content of vertical grain and heartwood. No. 1 shingles are available natural or pressure impregnated with fire retardants for Class A, B, and C roof requirements or they can be obtained with a .40 CCA pressure preservative treatment warranted for 30 years against rot and fungal decay by the treating company. Pressure fire retardant treatments and pressure preservative treatments cannot be combined. No. 2 RED LABEL is satisfactory for some less exposed siting situations, but has significant amounts of flat grain and will not perform as well as No. 1. Since the installation costs are the same, No. 1 or premium shingles will be more cost-effective in the long-term. No. 3 BLACK LABEL is a utility grade for economy applications and secondary buildings. No. 4 UNDER COURSING is used for under coursing, or shimming. (NOTE: A number of suppliers are not members of CSSB and their grading specifications may vary somewhat.)

ADVANTAGES: Preferred for its natural appearance for both traditional and modern houses, often simulated but never duplicated. Long history of satisfactory performance. Can be treated with preservative, shingle oil, stain, CCA, or fire-retardant, or can be left to weather naturally. Can be obtained in a variety of butt configurations. Western red cedar shingles are warranted for 20 to 30 years (depending on product) against material defects by CSSB members and independent suppliers or their treatment applicators. Available with premanufactured hip and ridge caps, wood shingles and shakes are more resistant to damage from high wind and hail than asphalt shingles. Being made from a renewable resource, cedar shingles are a sustainable choice.

DISADVANTAGES: More expensive than most other roofing materials. Can weather unevenly under certain conditions. More combustible, unless treated, than most other roofing products. Eastern white cedar is normally available only in random lengths with only 50 percent to 66 percent vertical grain, requiring the expense of culling out unacceptable pieces.

3. INSTALL NEW CEDAR SHAKES.

There are four basic types of cedar shakes available: No. 1 Handsplit & Resawn is the most popular, with hand-split faces and sawn backs. No. 1 Tapersawn are sawn on both sides and resemble thick butt shingles (also available in No. 2 and No. 3 utility grades). No. 1 Tapersplit shakes are produced largely by hand and are popular in preservation applications in a three-ply system, which does not require building paper in snow-free areas. No. 1 Straight Split shakes are the same thickness throughout and are used primarily on exterior walls, but occasionally on roofs. Shakes are thicker than shingles and are warranted against product defects (but not installation) for 25 years. They are used primarily when a more rustic or rugged roof character is desired than that possible with shingles.

ADVANTAGES: Material imparts deep shadows and strong texture to roof surface. Classic, natural material for both traditional and contemporary buildings. Much copied, but never replicated. Can be treated with preservative, stain, CCA, or fire-retardant, or can be left to weather naturally. Treated heavy shakes are warranted for 50 years by some manufacturers. Available with premanufactured hip and ridge caps. Being made from a renewable resource, cedar shakes are a sustainable choice.

DISADVANTAGES: More expensive than other roofing types including shingles. Can weather unevenly. More combustible than other roofing materials unless treated with fire retardant. Some warping and cupping will occur.

4. INSTALL NEW SOUTHERN YELLOW PINE SHAKES.

Southern yellow pine shakes have been available since the 1970s, but were not actively promoted until the late 1980s. Initial interest out-stripped manufacturing capabilities and the capacity remains limited to a relatively small market within the Eastern and Midwestern states. Available taper sawn in No. 1 and No. 2 grades in lengths of 18 and 24 inches with a butt thickness of $\frac{13}{16}$ inch. Southern yellow pine shakes are heavier, thicker, and denser than cedar shingles. All shakes are pressure treated with CCA preservative and are warranted against rot and decay by the treating agency for 30 years. The material weathers a natural gray. Southern yellow pine shakes can be applied on solid sheathing because they are treated, but venting by means of furring strips is recommended. Shakes can be applied over existing wood or composition shingles, but application over sheathing is preferred.

ADVANTAGES: An attractive, heavily textured roof used in high-end custom housing and historic restoration projects. Material is warranted for 30 years against decay, rot, and termites. Performs better than other, lighter materials in high winds and hail storms. Approximately the same cost as untreated cedar shakes. Being made from a renewable resource, pine shakes are a sustainable choice.

DISADVANTAGES: Heavier than cedar shakes; roof structure may require strengthening. More expensive than some other roofing products. Cannot be treated with fire retardant when treated with CCA. Some warping and cupping will occur.

FURTHER READING

Cedar Shake and Shingle Bureau Design and Application Manual for New Roof Construction, Cedar Shake and Shingle Bureau, 515 116th Avenue, NE, Suite 275, Bellevue, WA 98004; 425-453-1323; www.cedarbureau.org.

Cedar Shake and Shingle Bureau Membership Directory and Buyer's Guide, Cedar Shake and Shingle Bureau, 515 116th Avenue, NE, Suite 275, Bellevue, WA 98004; 425-453-1323; www.cedarbureau.org.

"A Guide to Southern Pine Shakes," Southern Forest Products Association, P.O. Box 641700, Kenner, LA; 504-443-4464; www.southernpine.com.

"Long Lasting Wood Roofs," Patricia Hamilton, *Journal of Light Construction*, May 1997.

"Wood Shingle Roofs—Best Job Specifications and Care," *Old House Journal*, May/June 1990, pp. 34-41.

PRODUCT INFORMATION

Cedar Breather™ and Roll Vent for Cedar, Benjamin Opdyke, Inc., 65 Steamboat Drive, John Fitch Industrial Park, Warminster, PA 18974-4889; 800-346-7655.

Ice & Water Shield™, W.R. Grace & Co., Construction Products, 62 Whitmore Avenue, Cambridge, MA 02140; 617-876-1400.

Winterguard™, Certainteed Corp., Roofing Products Group, P.O. Box 860, Valley Forge, PA 19482.

PARTIAL LIST OF CSSB MEMBER AND NON-MEMBER SUPPLIERS OF WOOD SHINGLES*

Amaraut Wood Products, Inc., P.O. Box 1008, 4935 Boyd Road, Arcata, CA 95521; 707-822-4849 (redwood shingles and shakes).

Ambrook Industries Ltd., 17360 Frazer Dyke Road, Pitt Meadows, B.C., Canada V3Y 1Z1; 604-465-5657 (Western red cedar, wholesale and retail).

Clarke Group Marketing, Inc., P.O. Box 515, Sumas, WA 98295; 800-963-3388; www.cedarplus.com (largest manufacturer of cedar shake and shingle products).

Sovbec, Inc., 9201 Center Hospitalier Boulevard, Chary, Quebec, Canada G6X 1L5; 418-832-6181 (Largest supplier of Eastern white cedar, representing 26 mills).

Teal Cedar Products, 17897 Trigg Road, Surrey, B.C., Canada V3T 5J4; 604-581-6161 (Western red cedar and yellow cedar; wholesale only; good source of information about shingle and shake products).

Watkin Sawmills, P.O. Box 314, Sumas, WA 98295; 800-663-8301 (Western red cedar; wholesale and retail).

*A complete list of the approximately 608 supplier and installer members of the Cedar Shake and Shingle Bureau is found in the *Cedar Shake and Shingle Bureau's Membership Directory and Buyer's Guide*.

ESSENTIAL KNOWLEDGE

Asphalt shingles were introduced into the roofing market in the late-1800s as a by-product of making tar and asphalt-impregnated felts for flat roofs. Early shingles contained up to 33 percent cotton or wool fibers derived from rags, hence the term “rag felt.” From the early 1940s to the late 1970s asphalt shingle mat was comprised of organic cellulose fibers derived from recycled waste paper and/or wood fiber. Although organic mat is still available, the dominant base material since the late 1970s has been inorganic (fiberglass) mat. According to recent sales information from the Asphalt Roofing Manufacturing Association (ARMA), fiberglass mat shingles comprise approximately 82 percent of the residential asphalt shingle roofing market, and organic mat shingles (still popular in the Midwest and Northeast because they are more flexible and considered easier to install in cold weather) 18 percent. ARMA estimates that asphalt shingles represent 80 to 85 percent of the total residential roofing market.

The fiberglass mat typically used in the asphalt shingle industry is lighter than organic mat. Fiberglass mat doesn't necessarily perform better but does allow shingles to meet Class A fire resistance ratings, while organic mat only meets Class C. Organic mat is presaturated with asphalt and then coated with a mineral-stabilized material (limestone, slate, flyash, or traprock). Inorganic (fiberglass) mat is coated with mineral-stabilized material but not presaturated. The mineral-stabilized coating fills the voids between individual mats while at the same time providing increased resistance to fire and weather.

The typical asphalt shingle has been for many years a 36 by 12-inch three-tab strip shingle. The cut-outs between the tabs create the illusion of individual shingles (Fig. 1). Within the last five or ten years, “Architectural” or laminated shingles that simulate wood and slate shingles or shakes have become increasingly popular for higher end housing. These shingles are made of two or even three layers laminated into a single unit. The multiple laminate reinforces the impression of individual shingles and the protective granules are toned to simulate weathered material. Dark colored granules are added to create the impression of shadows, thereby enhancing the three-dimensional, “high definition” effect (Fig. 2). Dark colored granules are also added to some three-tab shingles, such as Owens Corning's Prominence® series to simulate the appearance of premium shingles (Fig. 3). Other recent developments include the increasing use of larger-sized “metric” shingles, longer “multi-tabbed” shingles, and distinctly-styled, non-rectangular, diamond and hexagonal (scalloped) shingles (Fig. 4).

The proliferation of different asphalt roofing shingle types and styles has made the selection of these materials difficult. In the recent past shingles were categorized by weight, such as 235, 240, 280 pounds, etc. The weight was generally related to service life. Currently shingles are classified by warranty duration, such as 20, 25, 30, or 40-year. There is no direct relationship between base mat thickness, shingle weight, performance, and warranty. Furthermore, asphalt coatings, the type of fillers, mat thickness, and shingle weight vary from one manufacturer to another, making it difficult to estimate relative performance. Most of the laminated shingles have been on the market for only the past five to ten years, and there is no long-term history of their performance (the Insurance Institute for Property Loss Prevention assumes that the effective life of an average asphalt shingle is 17 years). There is also no applicable American Society for Testing Materials (ASTM) accelerated wear test that is appropriate for asphalt shingles. Manufacturer warranties are apt to differ in terms of what is warranted (material, labor, or both), against what defect, for what period (pro-rated or not), with what exclusions (rain, hail, and other variables), or whether the warranty is transferrable.

In response to widespread reports of product failure in the early 1990s, the Midwest Roofing Contractors Association (MRCA) ran shear strength tests on a number of shingle types (asphalt fiberglass, asphalt organic, asphalt laminated fiberglass, and asphalt laminated organic shingles) in accordance with

INDIVIDUAL TILE



TILE PATTERN



THREE-TAB SHINGLE

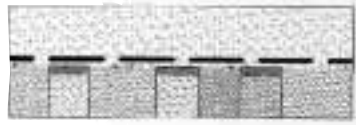

LAMINATED SHINGLE

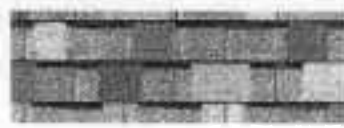

"SHADOWED" THREE-TAB SHINGLE

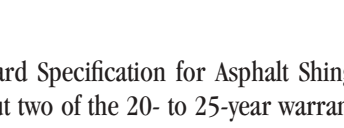
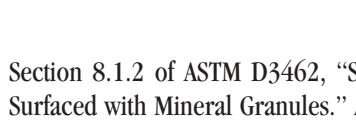

"SHAPED" SHINGLE

FIGURES 1–4
(TOP–BOTTOM)

Section 8.1.2 of ASTM D3462, "Standard Specification for Asphalt Shingles Made from Glass Felt and Surfaced with Mineral Granules." All but two of the 20- to 25-year warranted three-tab asphalt fiberglass shingles, and all of the 25- and 30-year warranted asphalt laminated fiberglass shingles failed to meet the test. The ARMA maintains that tensile strength, tensile elongation, and shingle flexibility are better indicators of potential resistance to shingle splitting than tear strength, and is working through ASTM to improve the D3462 standard to more accurately reflect shingle performance. ARMA maintains that some shingles that don't meet D3462 perform adequately. Most manufacturers currently produce shingles that meet ASTM D3462, and this standard is increasingly referenced by model code agencies. However, some manufacturers, responding to requests for inexpensive products, make "commodity" 20- and 30-year shingles that do not meet this standard. These shingles, of varying quality, are often sold through discount wholesale and retail outlets stores that supply very price sensitive markets. Until the standards are revised, MRCA and some other industry representatives recommend purchasing organic or fiberglass shingles that are certified as meeting the tear-strength requirements of ASTM D3462.

A recent development in asphalt shingles is algae-retardant surfacing. Manufacturers have in the past experimented with zinc granules to retard algae growth, but these sometimes resulted in white patches and uneven staining. At least one manufacturer, 3M, that provides granules for roofing manufacturers has developed ceramic-coated granules that release copper ions over a 10-year period to help reduce the darkening of roofs from algae in hot, humid climates. For the additional cost of \$150 to \$300 per house, 3M claims that roofs will not require as frequent cleaning, which can remove surface granules. It is too early to evaluate the long-term effectiveness of this material, but there are indications that in the short term it helps retard algae discoloration.

If installing asphalt roofs in hurricane-prone regions, it should be noted that manufacturers generally do not warrant their products for wind speeds greater than 80 mph. Asphalt shingles have frequently

performed poorly in high winds, and can be a significant source (along with other roofing products) of wind-blown debris. Such performance, manufacturers point out, is frequently attributed to improper application, substrates, or fasteners (staples are not recommended). The industry and some regional standards (such as the “Blue Sky” guidelines developed by the Town of Southern Shores, North Carolina) recommend doubling up on weight of shingle underlayments, using polymer-modified asphalt underlayment membranes (such as Ice & Water Shield™ or WinterGuard™) instead of, or in addition to, roofing felts, and increasing the nailing pattern from 4 to 6 per shingle and the nail size to 1-1/4-inch #12 nails with 3/8-inch head diameter. Shingles at roof boundaries such as rakes, ridges, hips, and valleys should be secured with hand tabbing of an asphaltic roof cement. Existing shingles should be removed prior to reroofing and the existing sheathing inspected for deterioration. Some municipalities, such as Metro Dade County, Florida, have special requirements, such as allowing only shingles that pass 110 mph testing (but which are not typically warranted by manufacturers beyond 80 mph).

Partly in response to cold temperature and high-wind performance requirements, some manufacturers produce shingles derived from recent flat roof technology developments, with different base mat materials and configurations, as well as modified asphalt formulae. Malarkey Roofing Co. (with distribution largely in the Northwest) offers a shingle that has a base mat of fiberglass and polyester and an SBS rubberized asphalt (modified with styrene-butadiene-styrene) that it claims increases shingle flexibility to resist tearing and cracking under normal as well as low temperatures. Malarkey makes a three-tab and laminated shingle that is warranted against material failure in up to 100 mph winds. Another manufacturer, IKO, produces a plastic polymer-modified asphalt shingle (atactic polypropylene) with similar enhanced performance claims.

TECHNIQUES, MATERIALS, TOOLS

1. REPAIR EXISTING ASPHALT SHINGLES.

Isolated small holes or cracks in shingles can be temporarily repaired by troweling on plastic roofing cement. Curled shingles can often be cemented back in place. Individual shingles that are badly damaged can be replaced by slipping a pry bar under the damaged shingle, removing the nails, sliding the shingle out, replacing the shingle, and applying roofing cement to the new nail heads and the bottom edge of the new shingle, and the one above. If a large number of shingles exhibit excessive drying out, curling, loss of protective granules, cracking, or other deterioration, or if there is evidence of significant leaks that are not due to faulty flashing, then a complete shingle replacement is likely to be required.

ADVANTAGES: Repairs are easy to make and are cost-effective over small areas.

DISADVANTAGES: If large areas need replacement, or if serious leaks develop, postponing replacement may cause damage to the building's structural elements or finishes.

2. INSTALL NEW ASPHALT SHINGLES.

A critical decision will be whether or not to remove the existing shingles or apply the new shingles over the existing layer. According to ARMA, in many cases it is not necessary to tear off the old shingles if the roof has only one layer of shingles, is laying flat and the decking is in good condition. In this instance, the existing asphalt shingles can provide a secondary moisture barrier and the cost of removing and disposing of the old shingles will be eliminated. The existing shingles will probably have to be removed, however, if an inspection of the roof sheathing/substrate reveals significant rotting or warping of sheathing members, if there is more than one existing layer of asphalt shingles on the roof, if the roof structure shows signs of sagging along the ridge or truss lines, or if the condition of the existing shingles is so rough and distorted that new roof shingles would not lay flat. If the roof does not look straight and feel solid, it should be inspected for structural adequacy by a professional engineer or architect. The advice of an experienced roofing consultant or contractor can assist in the determination of the appropriate installations. If there is any serious doubt, a complete removal will lead to the most satisfactory application, as it allows a complete assessment of the condition of the existing roof and will provide the base for a level and flat installation.

In any case, adequate roof ventilation should be provided (see “Further Reading”). Ideally, asphalt shingles should be installed only when the temperature ranges between 40°F and 85°F. At temperatures lower than 40°F shingles become brittle, crack easily, and are hard to cut. At ground-level temperatures of 85°F and above, roof temperatures can be in the mid-100s and the granular material is easily disfigured and scuffed by handling and walking on the roof’s surface. In hot climates, roofers usually begin work at day-break and quit early. In colder climates during the winter, the seal tab adhesives may not set up initially, especially on light, reflective roofs. Seal tabs may also not set up properly on very steep roofs with slopes over 21 on 12. These installations often require additional applications of roofing cement (see “Further Reading” for cold weather and high slope application recommendations). Application procedures are critical: incorrect nailing above the seal tab line or over-driven nails can lead to product failure. Shingle manufacturers and ARMA recommend against directly applying asphalt shingles on insulation or radiant barrier decks (see Further Reading).

ADVANTAGES: Available in a wide range of types, colors, and patterns, asphalt shingles are by far the most popular residential roofing material. Under most conditions asphalt shingles perform satisfactorily. Laminated shingles can dramatically enhance the building’s appearance, especially those with higher roof pitches. Can be applied over one layer of flat existing asphalt shingles, but reroofing directly over sheathing is best. Relatively economical material with low first costs, compared to other materials. Easily installed.

DISADVANTAGES: Confusing claims and warranties, and the proliferation of material types and specifications, make it difficult to compare and evaluate different manufacturers’ products. Competing products are not necessarily equal, and warranties, specifications, and testing data should be carefully examined and compared. Some asphalt shingle products may perform unsatisfactorily, especially in hot, arid climates where thermal shock conditions (high heat with rapid cooling from thunderstorms) occur. Roofs may darken or stain from excessive moisture or humid conditions. Being a product of nonrenewable fossil materials, asphalt shingles are not the best choice from a sustainability standpoint.

FURTHER READING

“Algae Discoloration of Roofs,” ARMA Technical Bulletin #217-RR-89.

“Blue Sky Construction Guidelines,” Town of Southern Shores, NC.

“Builder Tips—How to Minimize the Buckling of Asphalt Composition Shingles,” APA, the Engineered Wood Association, Form No. K310F/revised April 1994; www.apawood.org/buildertips/buckling.html.

Certainteed Shingle Application Manual, Certainteed Corp., P.O. Box 860, Valley Forge, PA 19482, 3rd edition, 1997-98.

“Cold Weather Recommendations for Application of Asphalt Roofing Shingles,” ARMA Technical Bulletin #225-RR-97.

“Direct Application of Asphalt Shingles Over Insulation or Insulated Decks,” ARMA Technical Bulletin #211-RR-86.

Residential Asphalt Roofing Manual, Asphalt Roofing Manufacturers Association, 1997, www.asphalt-roofing.org.

Residential Steep-Slope Roofing Materials Guide, National Roofing Contractors Association; www.roof-online.org.

“Recommendations for Application of Asphalt Shingles on Steep Slopes and Mansard Construction,” ARMA Technical Bulletin #213-RR-87.

“Reroofing: Tear-Off vs. Re-Cover,” ARMA Technical Bulletin #223-RR-96.

“Shingles and Siding: How to Know When You Need Them—Costs, Product Tests,” *Consumer Reports*,

August 1997, P.O. Box 2015, Yonkers, NY 10703–9015.

The Steep Roofing Manual, National Roofing Contractors Association, www.roofonline.org.

“Ventilation and Moisture Control for Residential Roofing,” ARMA Technical Bulletin #209-RR-86.

PRODUCT INFORMATION

ASPHALT SHINGLES

Atlas Roofing Corp., 1775 The Exchange, #160, Atlanta, GA 30339; 770–993–4479.

Bird Inc., 1077 Pleasant Street, Norwood, MA 02062; 800–BIRD–INC.

BPCO, P.O. Box 3177, Wayne, NJ 07474–3177.

Celotex Corp., P.O. Box 31602, Tampa, FL 33631; 800–CELOTEX (phone); 813–873–4080 (fax); www.celotex.com.

ELK, 14643 Dallas Parkway, Suite 1000, Dallas, TX 75240; 972–851–0400; www.elcor.com.

GAF Materials Corp., 1361 Alps Road, Wayne, NJ 07470; 800–766–3411; www.gaf.com.

Georgia-Pacific Corp., 4300 Wildwood Parkway, Suite 300, Atlanta, GA 303TK; 800–839–2588; www.gp.com.

Globe Building Materials, Inc., 2230 Indianapolis Boulevard, Whiting, IN 46394; 219–473–4500.

GS Roofing Products Co., 5525 MacArthur Boulevard, Suite 900, Irving, TX 75038; 972–580–5600; www.gsroof.com.

Herbert Malarkey Roofing Co., P.O. Box 17217, Portland, OR 97217; 800–545–1191 (phone); 503–283–5405 (fax); www.malarkey-rsg.com.

IKO Manufacturing, Inc., 120 Hay Road, Wilmington, DE 19809; 302–764–3100.

Owens Corning, One Owens Corning Parkway, Toledo, OH 43659; 800–438–7465 (phone); 419–248–7354 (fax); www.owenscorning.com.

PABCO Roofing Manufacturers, 1718 Thorne Rd., Takoma, WA 98421; 206–272–0374.

ICE AND WATER BARRIERS*

Ice & Water Shield™, W.R. Grace & Co. Construction Products, 62 Whitmore Avenue, Cambridge, MA 02140; 800–472–2391.

Winterguard™, Certainteed Corp., Roofing Products Group, P.O. Box 860, Valley Forge, PA 19482.

*For a more comprehensive list of ice and water barriers, see Section 5: *Underlayments and Moisture Barriers*.

ALGAE MITIGATION

3M™, Algae Block™, System, 3M Industrial Mineral Products Division, 3M Center 225-2N-07, P.O. Box 33225, St. Paul, MN 55133–3225; 800–447–2914.

LOW-SLOPE ROOFING

ESSENTIAL KNOWLEDGE

All roofing systems are subject to leaks, but low-slope roofs do not shed water as effectively as high-slope roofs and are more susceptible to damage from water infiltration. Some of the causes of water leaks can be mitigated by careful maintenance, but others such as those caused by deficient design and installation; long-term weathering and Ultraviolet (UV) exposure; extreme weather conditions including snow, hail, high winds, and drenching rains (that raise the water level above base flashing height); structural deficiencies and changes; and excessive thermal expansion and contraction, cannot. The causes of roof leaks are often difficult to determine accurately and leaks frequently result in damage at some distance from their source.

An inspection for roof leaks should begin in the building's interior, noting all signs of moisture infiltration, such as stained or deteriorated roof decks, structure, ceilings, and walls. Before corrective work is undertaken, roofs should be inspected by a qualified roofing consultant or contractor to document general problem areas beginning with the obvious ones. These include obstructed or non-performing drains, scuppers, gutters, or leaders; the existence of foreign matter such as tree limbs, debris, leaves, and pine needles that block drains and puncture roof membranes; displaced ballast or walkway pavers; wear and tear on roofs used for recreation; and uneven, settled, or depressed roof areas that prevent proper drainage and lead to ponding. If the roof is under a manufacturer's warranty, the roofing membrane manufacturer should be contacted as soon as possible about any roof leaks. Upon completion of a general survey, a more detailed inspection should address the condition of each roof component, including: copings, cap and counter flashings; gravel stops, roof edging and fascia; base flashing, pitch pockets and boots at roof penetrations; deteriorated sealants; and roof membranes, including unbonded or unsealed seams, the existence of ridges, blisters, wrinkles, worn spots, holes, or deteriorated areas. The National Roofing Contractors Association (NRCA), the Asphalt Roofing Manufacturer's Association (ARMA), and the Single Ply Roofing Institute (SPRI) have jointly produced a useful checklist of items to be surveyed (see Further Reading).

The low-slope roofing materials discussed below include built-up roof membranes, modified bitumen membranes, and thermoset and thermoplastic single-ply membranes.

TECHNIQUES, MATERIALS, TOOLS

1. REPAIR EXISTING BUILT-UP ROOF (BUR) MEMBRANE.

Spot repairs address deficient or degraded conditions at isolated locations in the roof membrane or base flashings. Most repairs of punctured, cracked, blistered, wrinkled, or otherwise distressed areas involve similar repair strategies including: the removal of debris, contaminants or aggregates; checking for water damage to the insulation or decking; removal and replacement if necessary; cutting out of damaged section of membrane; priming the membrane and installation of new plies (to match the number removed) in hot bitumen or cold-applied adhesive. A variety of resaturants and liquid coatings exist that extend the life of existing surface coatings. Some contain pigments that reflect solar radiation. The National Roofing Contractors Association and the Asphalt Roofing Manufacturers Association have both produced a number of comprehensive manuals of maintenance procedures and recommended repairs (see Further Reading). Permanent repairs should be undertaken by a professional roofing contractor.



FIGURE 1

BUR BEING INSTALLED

ADVANTAGES: Spot repair can be cost-effective in increasing the service life of both new and worn roofs.
DISADVANTAGES: As with all roofing systems, if roof problems are widespread, or if serious water problems exist, spot repairs may not be effective.

2. REPLACE EXISTING ROOF WITH BUILT-UP ROOFING MEMBRANE.

Built-up roofing (BUR) systems comprise multiple overlapping layers of roofing felt coated with asphalt or coal tar pitch (Fig. 1). BUR systems are classified into two major categories: asphalt systems and coal tar systems. Asphalt is derived from the refining of crude oil, coal tar is derived from the refining of coal. Although they are both used in conjunction with plies of roofing felt, with fiberglass or polyester fabric reinforcement, they have quite different properties and are not necessarily interchangeable. Asphalt-based products should typically be used for the repair of asphalt BURs and coal tar products for the repair of coal tar BURs, with the exception that asphaltic-based products are routinely used for the construction of base flashings in coal tar BURs. BURs have been in use over 150 years; many 50-year-old and older roofs are still in service. Coal tar roofing pitch comes in three grades or types that have varying viscosities. Type I is the most prevalent. Coal tar is used basically for low slopes and is not recommended for slopes greater than $\frac{1}{4}$ in 12 inches. In warm climates this slope factor is reduced to $\frac{1}{8}$ in 12 inches. Coal tar roofing pitch is the only material with true cold-flow properties which give it self-healing characteristics beginning at surface temperatures of approximately 60°F (experienced during winter months due to solar radiation). Asphalt is also available in a variety of types according to their viscosity and softening points. Type I asphalt's softening point is 135°F and is used only on roofs with no appreciable slope. Type III asphalt, called "steep asphalt", can be installed on roofs with a maximum slope of 3 in 12 inches. Its softening point is between 185°F and 205°F . Type III is the most commonly used asphalt in BUR because of its in-service softening point. Asphalt BURs are available in both conventional hot-applied and cold-process roof systems which mix asphalt with petroleum distillates, polymers, fibers, and fillers. Cold-process roof systems are usually brush-applied or applied by commercial airless spray equipment, instead of being hand-mopped or applied by mechanical asphalt spreaders; they normally require fewer plies; undesirable fumes and the danger of hot spills are said to be eliminated.

ADVANTAGES: BUR systems, properly designed and applied, have a long history of successful use and can perform well for many years. Cold-process systems can minimize undesirable fumes, and are economical. BUR systems can be relatively easily maintained and repaired, and can be more forgiving of installation errors, due to the redundancy of multiple plies, than other systems.

DISADVANTAGES: Built-up roofing systems, as with all roofing systems, depend on close adherence to specifications and require careful workmanship for their performance. Air pockets must be limited and applying the proper amount of adhesives is critical. Aggregate surfaces on coal tar and some asphalt BUR systems make identification of source of leaks difficult.

3. REPAIR EXISTING MODIFIED BITUMEN (MB) MEMBRANE

The ARMA/NRCA/SPRI's recommended repair strategies for MB membranes include: inspection of the roof membrane for water infiltration; removal and replacement of damaged or wet insulation or deteriorated decking; removal of debris, contaminants, ballast, aggregate, or loose granules; priming of the membrane surface; patching surface with a similar material 8" wider in all dimensions with 3" radius corners; installation of the patch in hot asphalt (if styrene butadiene styrene [SBS] but not atactic polypropylene [APP], cold adhesive, or by heat welding in accordance with the roofing manufacturer's recommendations [see Further Reading].

ADVANTAGES: Can increase the service life of new and worn roofs. Cost-effective.

DISADVANTAGES: If roof problems are widespread or if serious leaks persist, localized repairs may not be effective and more general repairs or replacement may be necessary.

4. REPLACE EXISTING ROOF WITH MODIFIED BITUMEN (MB) MEMBRANE

Modified bitumen (MB) membranes are made from asphalt or coal tar pitch bitumens modified with chemicals (polymers) to provide enhanced weatherability, flexibility, tensile strength, and resistance to flow at high temperatures. The most common polymers used to modify asphalt bitumen are APP and SBS. Other modifiers include SBR, EIP, and SEBS. Coal tar pitch bitumen can be modified with Tardyne® polymers to create a MB that is compatible with coal tar BUR roofing systems. However, most MBs combine asphalt, reinforcing fabric such as polyester or fiberglass, and APP or SBS polymers. Most MBs are supplied in rolls covering 100 sf (one square), installed in multiple plies. Although they differ significantly from single-ply thermoset and thermoplastic membranes, MBs are sometimes grouped with those systems into a new classification, "flexible membrane systems."

APP systems are normally applied with an open-flame torch process, but are also installed with hot-air welding equipment and can be obtained in a peel-and-stick sheet form or in rolls compatible with cold-process adhesives. SBS systems are normally installed with hot asphalt moppings, but can also be installed with open-flame, hot-air self adhesive, and cold adhesive process. A variety of surfacings is available, including asphalt cutback aluminum coatings, ceramic granule or mineral surfacing (similar to asphalt composition shingles) and occasionally with aggregate toppings. MBs with factory-applied ceramic granules are more expensive than unsurfaced sheets but are cost-effective from a life-cycle cost view. Life expectancy of roofs can be increased with additional layers of MB (or smooth surfaced sheets) in the roof's field or at flashings. Currently MB systems are frequently combined with BURs into a hybrid roof, i.e., two plies of BUR and a MB cap sheet for a high tensile strength (BUR), highly flexible (MB) system. Coatings, such as reflective aluminum roof coatings, can also increase service life, although they require periodic renewal.

ADVANTAGES: Available in a variety of configurations and surface coatings. An increasingly popular alternative to BUR systems. Easier to install and detect possible roof leaks than aggregate-surfaced BUR roofs. Can accommodate some roof traffic.

DISADVANTAGES: Requires installers familiar with its use. Requires careful attention to installation details, particularly seaming. Life expectancy may be greatly reduced by ponding water. Products containing new polymer types should be carefully researched due to limited history of satisfactory use.

5. REPAIR EXISTING THERMOSET AND THERMOPLASTIC SINGLE-PLY ROOFING MEMBRANE.

Emergency patching of single-ply roofing systems can be made with duct tape, roofing tape, polyethylene sheets, wood blocking, or butyl or polyurethane sealants, depending on size and severity of damage. Plastic roofing cement and fabric patches are acceptable if other means are not possible, but roofing

cement may deteriorate some types of single-ply membranes (particularly PVC) and possibly insulation as well. Avoid the use of liquid or pourable asphalt repair products. Single-ply roofing systems require permanent repairs that are compatible with the individual materials and systems chosen. An excellent source of permanent repair guidelines is provided in ARMA/NRCA/SPRI's *Repair Manual for Low-Slope Membrane Roof Systems*. Permanent repairs should be undertaken with professional roofing contractors experienced with the systems at hand. Roofing manufacturers should be consulted to confirm the appropriateness of individual repair techniques (See Further Reading).

ADVANTAGES: Permanent spot repairs can be relatively simply made and are cost-effective in increasing the service life of both new and worn roofs.

DISADVANTAGES: If roof problems are widespread, or if serious water problems exist, spot repairs may not be effective.

6. REPLACE EXISTING ROOFS WITH NEW THERMOSET AND THERMOPLASTIC SINGLE-PLY ROOFING MEMBRANES.

Single-ply roofing membranes, currently promoted as “flexible membranes,” were first used in the US during the late 1950s on such architecturally significant projects as Dulles Airport. Widespread commercial applications developed in the 1970s spurred on by oil shortages and increases in the cost of petroleum-based products (such as BUR) caused by the Arab Oil embargo. Currently, according to the SPRI, flexible membranes comprise approximately 55 percent of the total commercial roofing market. While their use is largely in commercial projects, they are also used on low-sloped multifamily and townhouse projects, both for rehabilitation and new construction.

In addition to modified bitumen, previously discussed, flexible membranes are grouped into thermoset and thermoplastic categories (Table 1). Thermoset membranes include EPDM and CSPE, first introduced in 1951 under the trade name Hypalon and neoprene (also known as chloroprene rubber). In thermoset materials, polymers are cross-linked during the manufacturing process for EPDM and during exposure to heat and light (curing) in the case of CSPE. Seaming of thermoset materials has traditionally been accomplished by means of liquid adhesives, or more recently by the use of specially formulated tape. Newer formulations of CSPE are seamed by means of heat welding.

TABLE 1

POLYMERS USED IN FLEXIBLE ROOFING MEMBRANES

Polymer Category	Abbreviation	Generic Classification
Butadiene Acrylonitrile Polymers	NBP	Thermoplastic
Chlorinated Polyethylene Polymers	CPE	Thermoplastic
Chlorosulfonated Polyethylene Polymers	CSPE	Thermoset
Copolymer Alloys	CPA	Thermoplastic
Epichlorohydrine Polymers	ECH	Thermoset
Ethylene Propylene Polymers	EPDM	Thermoset
Ethylene Interpolymers	EIP	Thermoplastic
Isobutylene—Isoprene Polymers	PIB, IIR	Thermoplastic
APP Modified Bitumen	MB	Modified Bitumen
SBS Modified Bitumen	MB	Modified Bitumen
Polyvinyl Chloride Polymers	PVC	Thermoplastic
Thermoplastic Polyolefin	TPO	Thermoplastic

Certain materials may be derived by combining two or more of the polymers shown.

Thermoplastic membranes include PVC, PVC blends, or alloys such as CPA, EIP, and NBP. PIB and TPO are based on polypropylene and ethylene propylene polymers. Thermoplastic membranes differ from thermosets in that there is no cross-linking or vulcanizing—they can be repeatedly softened by heating and will reharden when cooled. This allows them to be seamed together by special heat welding equipment

which is an increasingly efficient, economical and popular form of sealing that provides more uniform attachment than that usually attained by the use of solvents. Flexible membrane roofing systems can be attached to the deck and roof insulation with mechanical fasteners; adhesives including special glues; hot asphalt or cold adhesive; or loosely laid with gravel ballast or concrete pavers. Each installation has its advantages and disadvantages which should be carefully researched.

Some flexible membranes such as PVCs, EPDMs, and CSPEs have been successfully used for over 30 years. Some are new formulations of existing products (CPAs, EIPs, and NBPs). Others including TPOs are quite recent developments, and even newer products and formulations are continuously being developed. A comparison of individual products is made difficult because of the complexity and large number of competing products, the lack of comprehensive qualitative comparative data and continuing product evolution. Some data is available from SPRI (in particular its reference manual titled *Flexible Membrane Roofing: A Professional Guide to Specifications*) and individual product manufacturers, but an informed choice will require an evaluation of comparative data including product history (successes and failures); weatherability; chemical and flame spread resistance; slope characteristics; tear and puncture repairability; ability to resist roof traffic wear; compatibility with associated materials (flashings and insulation); color and roll size; warranties; installation choices, procedures, and details; availability of reinforcing screens; life-cycle costs; and availability of experienced applicators (sometimes the most critical determinant of all).
ADVANTAGES: Broad range of products, colors, surfacings, application methods, and engineering/design solutions. Can be applied to complex roof profiles and can accommodate building movement. Lightweight, can be used over existing roofing. Easy to install and inspect. Continuous research and development of systems in use and new systems. History of satisfactory performance.

DISADVANTAGES: It is difficult to obtain accurate comparative data between systems; requires very careful quality control during product installation—poor application procedures have led to a number of failures, particularly at seams between rolls of materials. Some newer materials have limited history of successful use.

FURTHER READING

“Everything You Always Wanted to Know About Flexible Membrane Roofing, but Didn’t Know Who to Ask,” *The Roofing Specifier*, July 1998.

Flexible Membrane Roofing: A Professional’s Guide to Low-Slope Membrane Roofing Construction Details, Fourth Edition, NRCA Specifications, Single-Ply Roofing Institute, 1998.

Manual for Inspection and Maintenance of Built-up and Modified Bitumen Roof Systems: A Guide for Building Owners, NRCA/ARMA, 1996.

Manual of Low-Slope Roofing Systems, 3d ed., Griffen, C.W., and Fricklas, Richard C., McGraw-Hill, 1995.

Modified Bitumen Roofing Systems Design Guide, ARMA, 1997.

SPRI/NRCA Manual of Roof Inspection, Maintenance, and Emergency Repair for Existing Single-Ply Roofing Systems, NRCA/SPRI, April 1992.

Repair Manual for Low-Slope Membrane Roof Systems, ARMA/NRCA/SPRI, 1997.

Residential Asphalt Roofing Manual, ARMA, revised 1997.

Quality Control Guidelines for the Association of Thermoset Single-Ply Roof Membrane, NRCA, March 1996.

The NRCA Roofing and Waterproofing Manual—Fourth Edition, NRCA, 1996.

Time-Saver Details for Roof Designs, Steve Hardy, McGraw-Hill, 1998.

The Manual of Low-Slope Roof Systems, NRCA, 1996.

PRODUCT INFORMATION

MODIFIED BITUMEN MEMBRANE SUPPLIERS

GAF Materials Corporation, 1361 Alps Road, Wayne, NJ 07470; 973-628-3000; www.ispcorp.com.

Monsey-Bakor, 336 Cold Stream Road, Kimberton, PA 19442; 800-523-0268; www.monseybakor.com.

Siplast, 222 W. Las Colinas Boulevard #1600, Irving, TX 75039; 972-506-6212; www.siplast.com.

Tamko Roofing Products, 313 Wall Street, P.O. Box 1404, Joplin, MO 64802; 417-624-6644; www.tamko.com.

THERMOPLASTIC MEMBRANE SUPPLIERS

Bondcote Roofing Systems, 106 Lukken Industrial Drive, West, La Grange, GA 30240; 800-368-2160; 706-882-3410; www.bondcote.com.

Canadian General Tower Limited, 52 Middleton Street, Cambridge, Ontario N1R 5T6; 516-623-1630.

Cooley Engineered Membranes, Inc., PO Box 939, 50 Esten Avenue, Pawtucket, RI 02862-0939; 800-444-4023; 401-724-0490.

Duro-Last Inc., 525 Morley Drive, Saginaw, MI 48601; 800-248-0280, www.duro-last.com.

Sarnafil Inc., 100 Dan Road, Canton, MA 02021; 781-828-5400; www.sarnafilus.com.

Seaman Corporation, 1000 Venture Boulevard, Wooster, OH 44691-9360; 330-262-1111; www.seamancorp.com.

THERMOSET MEMBRANE SUPPLIERS

Carlisle Syntec Inc., 1285 Ritner Highway, P.O. Box 7000, Carlisle, PA 17013-0925; 717-245-7000; www.carlisle-syntec.com.

THERMOPLASTIC AND THERMOSET MEMBRANE

ERSystems, 2950 Niagara Lane North, Plymouth, MN 55447; 800-403-7747; 612-550-0038; www.ersystems.com.

Genflex Roofing Systems, 1722 Indian Wood Circle, Suite A, Maumee, OH 43537; 800-443-4272; www.genflex.com.

JPS Elastomerics Corp., Stevens Roofing Systems, Nine Sullivan Road, Holyoke, MA 01040-2800; 413-533-8100; www.stevensroofing.com.

Kelly Energy Systems, Inc., PO Box 2583, Waterbury, CT 06723; 800-537-7663; 203-575-9220.

Verisco, Inc., 3485 Fortuna Drive, Akron, OH 44312; 800-992-7662.

MODIFIED BITUMEN, THERMOSET & THERMOPLASTIC SUPPLIERS

Firestone Building Products, 525 Congressional Boulevard, Carmel, IN 46032-5607; 317-575-7000; www.firestonebpco.com.

Johns-Manville Corporation, Roofing Systems Group, 717 17th Street, P.O. Box 5108, Denver, CO 80217; 303-978-2000; www.jm.com.

ESSENTIAL KNOWLEDGE

Long a roofing choice in many parts of the world, metal was introduced into the US in the 18th century as a craft industry using small sheets of lead or copper fabricated on site into flat-seamed roofs. By the beginning of the 20th century, factory-formed sheets of flat and corrugated galvanized steel became available that were economical and did not require a full supporting roof deck. Used primarily for rural housing and utility buildings, steel roofing was initially considered a somewhat inferior product that often leaked, had a limited life, and wasn't very attractive. Copper was too expensive for all but the most costly housing and institutional projects.

In the years since World War II a number of factors have transformed residential metal roofing: the use of zinc/aluminum alloys has led to better corrosion resistance; improvement in coating systems that has reduced fading and chalking; better quality sealants that have increased weathertightness; and the use of fastening clips that has allowed for increased roof movement. In addition, the development of sophisticated site roll-forming equipment has allowed for longer, site-formed sections of roof panels, and the development of economical metal tile products that simulate other traditional roofing materials such as slate, clay tiles, wood shingles, and shakes has increased the range of roofing options.

TECHNIQUES, MATERIALS, TOOLS

1. REPAIR EXISTING METAL ROOFS.

All metal roofs and their fastenings will eventually fail due to the effects of normal weathering, severe wind and hail storms, corrosive airborne pollutants, rapid expansion and contraction and UV radiation. Localized problems can be repaired by replacing sections of damaged panels with patches of similar materials (applied with a sealant and screws if steel or aluminum, soldered if zinc or copper), or, preferably, by replacing the entire affected panel. Asphaltic patches or acrylic "elastomeric" repairs can be unsightly and are not normally long-term solutions. Some acrylic or polyurethane systems are available to recoat entire roofs, but many of these systems have limited lifetimes (1 to 5 years), are relatively unattractive, and generally appropriate primarily for low slope applications where the roof is not visible.

ADVANTAGES: Repairs can be cost-effective if limited to a few localized areas.

DISADVANTAGES: Repairs are not cost-effective if large sections of roof or flashings have deteriorated and structure or interior finishes are at risk. Replacement panels will not match color of existing panels.

2. REPLACE EXISTING ROOF WITH NEW STANDING SEAM METAL ROOF.

Standing seam roofing has become increasingly popular for both multifamily and high end, single-family housing, because it performs well and adds texture and color to simple roofs and continuity to complicated roofing profiles and elevations. It is available in pre-formed sheets and site-formed panels up to 100 feet long in a wide variety of materials including aluminum, copper, galvanized steel, Galvalume, Zinalume, painted steel, stainless steel, and zinc. Aluminum is sometimes specified for dry maritime areas where there is little rainfall to wash off the salt. Copper and zinc, the longest lasting materials, are sometimes specified for very high-end projects. Zinalume and Galvalume are also specified where their color characteristics are desired, but the dominant standing seam roofing material is pre-painted steel. Pre-painted steel roofing is made from cold-rolled coils of steel of varying thicknesses from 0.013 to 0.024 inch, coated in a continuous hot-dipped process with zinc, or zinc/aluminum alloys such as Zinalume and Galvalume (similar products). The coils are then finished with various paint systems including polyvinyl fluoride products

such as Kynar 500 and Hylar 5000 (similar products) or siliconized modified polyester (SMP). Polyvinyl fluorides with at least 70 percent resin content (some have less) are warranted to retain 85 percent of their original color for 20 years, SMPs will retain 80 percent of their color for 10 years (both have lifetime warranties against chipping or peeling).

Metal roofing systems are fabricated either at manufacturing facilities dedicated to that purpose, at the roofing contractor's own sheet metal facility, or at the job site using portable roll-forming equipment. Standing seam roofing systems are typically divided into two categories: architectural and structural. Architectural systems are usually installed on solid sheathing at slopes greater than 3:12 (although lower slopes can be accommodated) and are designed to shed water rapidly over the surface of the panels so the seams do not have to be watertight. Structural systems have more pronounced profiles, may be of heavier gauge, may use sealants applied to the seams, and generally span between purlins. Because they are for commercial applications, structural systems are not covered here. Traditional architectural standing seams include: overlap (bent flat to form a flat seam) (Fig. 1); single-lock (Fig. 2); and double-lock (Fig. 3). Single and double-locked seams are mechanically crimped with electric crimping tools. Double-locked seams are the most watertight of the residential systems. For very low slopes, butyl tape or sealant is sometimes used in the seam to increase the watertightness. Architectural panels typically have ribs $\frac{3}{4}$ to $1\frac{1}{2}$ inches high, are 12 to 16 inches wide (wider panels can allow oil-canning and substrate unevenness to show) and have clips at 36 inches o.c. to allow the roofing to "float" and compensate for expansion and contraction. Some systems use continuous clips and some less costly systems fasten directly to the substrate (which can cause fastener backout or tearing of the metal at the fastener penetration from expansion and contraction). Architectural panels are available in a number of gauges including: 28 ga. (sometimes used for utility buildings); 26 ga. (typically available only with siliconized modified polyester coatings) used in some cool climates such as the Pacific Northwest; and 24 ga., the most typical gauge, specified in hot, sunny, dry climates where maximum fade resistance is required (Kynar 500 or Hylar 5000 are unavailable from many suppliers in 26 ga. material).



FIGURE 1

OVERLAP (SEAM)



FIGURE 2

SINGLE LOCK (SEAM)



FIGURE 3

DOUBLE LOCK (SEAM)

Two more recently developed standing seam systems include the snap-on cap and the snap-lock. Snap-on cap systems (sometimes referred to as the mansard system because they were developed for high slopes) use a simple cap (in one system with a continuous vinyl weather seal) to cover the joint between panels (Fig. 4). A wider snap-on batten system is also available to provide a more pronounced rib (Fig. 5). Snap-lock systems employ specially formed ribs that snap and lock together (Figs. 6 and 7). Snap-lock and snap-on cap systems are less weathertight than double-locked systems and are usually restricted to slopes over 3:12. NRCA recommends a highly water-resistant underlayment be used under snap-on or snap-lock systems where leak-free performance is required. The NRCA also recommends that ventilation be provided between the underside of metal panels and the substrate, due to the great potential for condensation on the underside of the panel (the panels are an excellent thermal conductor and when temperatures fall below the dew point, condensation can occur on the panel underside).

ADVANTAGES: Attractive, available in a great variety of colors and materials. Easy to install, in some instances over existing roofing. Relatively long lasting, non-combustible. Resistant to decay, discoloration, and mildew. Wind resistant and water, snow, and ice shedding. Lightweight. Can be structural and placed over spaced purlins. Potentially recyclable.

DISADVANTAGES: Higher first cost than asphalt shingles and some other roofing products. Zinc/aluminum alloys may not be warranted within 1/4 mile of coast. Steel is a vapor barrier and can trap moisture leading to condensation if not ventilated. Careful detailing is required to mitigate condensation, excessive expansion and contraction, and uplift in high wind areas. Some installers may not be qualified. Warranties vary considerably and should be carefully reviewed. Roof warranties with longer duration (5 to 10 years) are preferred.

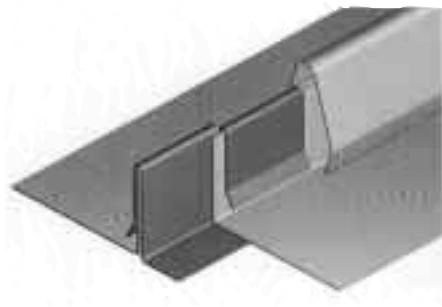

FIGURE 4

SNAP-ON CAP WITH CLIP



SNAP-ON CAP WITH VINYL GASKET

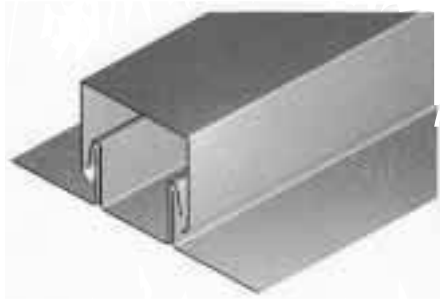

FIGURE 5

SNAP-ON BATTEN



FIGURES 6,7

SNAP LOCK

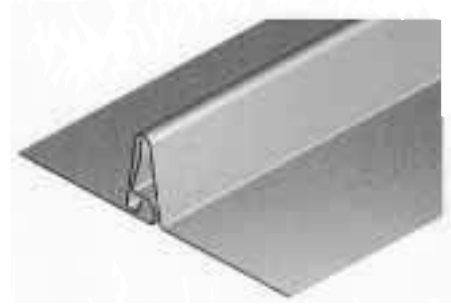

SNAP LOCK

3. REPLACE EXISTING ROOFS WITH METAL SHAKES AND TILES.

Metal roll-formed shakes and S-tiles were introduced more than 20 years ago. They have generated considerable interest recently because of their non-combustibility, light weight, and generally good performance in high wind areas. Typically made of 24 ga. galvanized or galvalumed steel with smooth polyvinyl fluoride coatings to simulate tile or with textured granules set in acrylic resins to simulate shakes. Metal tiles are available in small panels approximately 16 by 46 inches (Figs. 8 and 9) or in large panels up to 40 feet long (Figs. 10 and 11). Large panels can be placed on battens over solid sheathing, on battens on existing roofs, or over purlins spanning between roof rafters or trusses.

ADVANTAGES: Lightweight and strong due to molded surface. Non-combustible, wind, mildew, and rot-resistant. Available in a variety of textures, profiles, and colors. Economical, considering ease and speed of installations. Long-term material warranties.

DISADVANTAGES: Tiles may not closely resemble the materials they simulate. Requires ceiling insulation to reduce sound transmission.



FIGURES 8,9

TILE



SHAKE



"S" TILE—LARGE PANEL



SHAKE —LARGE PANEL

FIGURES 10,11

4. REPLACE EXISTING ROOF WITH FLAT METAL SHINGLES.

Several manufacturers make flat specialty shingle panels, including copper panels by Revere Copper Products, Inc. and Vail Metal Systems; a "Victorian" shingle made of prepainted or plain galvalume steel by the Berridge Manufacturing Co.; and a diamond shaped tile, "Castle Top," made in aluminum, copper, zinc, and pre-painted steel by Atas International, Inc. The copper shingles are nominally 12 by 48 inch panels embossed to look like individual shingles (Figs. 12 and 13). Vail Metal System's product was designed to function well in high snow and high wind environments. It is also available in prepainted metal. Berridge's Victorian shingle was developed for restoration applications (Fig. 14). All shingles are installed over conventional roof sheathing.

ADVANTAGES: Distinctive appearance, high wind and weather resistance, non-combustible, durable, will not decay, peel, or rot. Lightweight, easy to install.

DISADVANTAGES: More costly than other materials (copper is more than twice the cost of prepainted metal), takes longer to install than some other metal roofing products.



COPPER SHINGLE PANEL



COPPER SHINGLE PANELS

FIGURES 12,13



"VICTORIAN" TILE

FIGURE 14

FURTHER READING

“Alternative Roofing Materials,” *Journal of Light Construction*, August 1997.

Architecture Sheet Metal Manual, Sheet Metal and Air Conditioning Contractors National Association (SMACNA); www.smacna.org.

Copper in Architecture Handbook, Copper Development Association, Inc.; www.copper.org.

The Metal Roofing Manual, National Roofing Contractors Association, 1996.

Prepainted Metal Roofs, Video, National Coil Coaters Association, 1996.

Roof it With Steel, American Iron & Steel Institute; 800-79-STEEL.

PRODUCT INFORMATION

Atas International, Inc., 4559 Federal Boulevard, San Diego, CA 92102; 800-468-1441; www.atas.com (s-tile and shake panels, metal shingles, standing seam).

Berridge Manufacturing Co., 1720 Maury Street, Houston, TX 77026; 800-231-8127 (full line of metal roofing products).

Custom-Bilt Metals, 9845 Joe Vargus Way, South El Monte, CA 91733; 800-826-7813, www.custombilt-metals.com (full line of roofing products, 15 branches nationwide).

Dura-Loc Roofing Systems Limited, Box 220, RR 2, Courtland, Ontario, Canada N0J 1E0; 800-265-9357; www.duraloc.com (s-tile and shake panels).

Met-Tile, Inc., 1745 Monticello Court, P.O. Box 4268, Ontario, CA 91761; 800-899-0311; www.met-tile.com/roof (s-tile panels).

Perfection Co., 8512 Industry Park Drive, P.O. Box 1524, Piqua, OH 45356; 888-788-2427 (“Country Manor” aluminum shake).

Rheinzink Canada, Ltd., 4560 Dawson Street, Burnaby, British Columbia, Canada V5C 4C1; 604-291-8171 (zinc standing seam roofing).

Revere Copper Products, Inc., P.O. Box 300, Rome, NY 13442-0300; 800-490-1776.

Vail Metal Systems, LLC, P.O. Box 6521, Vail, CO 81658; 888-245-6385, www.vailmetal.com/roofing

COMPREHENSIVE LISTS OF MANUFACTURERS*

Product Capability Directory, National Coil Coaters Association, 1997.

Residential Steep-Slope Roofing Material Guide, National Roofing Contractors Association, 1997.

* *There are many manufacturers of metal standing seam roofs and metal tiles. A list of manufacturers and their products can be found in the above-referenced publications.*

ESSENTIAL KNOWLEDGE

Originally introduced into this country from England in the 18th century, slate has been a favorite roofing material for all types of buildings for more than 200 years. Its use peaked around the turn of the 19th century, when wood shingles were scarce because of clear-cutting of Eastern forests, and a noncombustible material was sought for the fast-growing cities of the East and Midwest. Demand abated after the 1929 Depression with the fall off in housing starts and introduction of lower cost asbestos and asphalt composition shingles. According to the National Roofing Contractor's Association, slate's share of the current residential roofing market is approximately 5 percent for new construction and 3 percent for reroofing.

The most common types of slate were formed millions of years ago from marine deposits of clay and sand. Less common types were formed from layers of volcanic ash. Slate is typically quarried in the U.S. in Virginia, Pennsylvania, New York, and Vermont along the Appalachian Mountain chain, as well as in Canada and Newfoundland. U.S. quarried slate roofs have a service life from 60 years for Pennsylvania soft vein slate (hard vein has not been quarried since the 1950s) to more than 125 years for New York and Vermont slate, to more than 175 years for Virginia Buckingham slate. Weathering of some slates' high calcium carbonate content can discolor slate; high iron oxide concentrations can lead to permanent discoloration due to the effect of acid rain. Some manufacturers will provide long-term warranties against delamination and softening due to freeze/thaw cycling.

In the last decade the increased interest in slate for use in high-end housing and restoration projects has led to the reactivation of some dormant quarries and the importation of tile from Spain, England, Newfoundland, Canada, and increasingly from countries with low labor costs such as Brazil, China, and India. The quality of imported tiles varies considerably depending on the specific quarry in the country of origin. Slate is graded largely according to hardness under ASTM C406-89. The grade normally specified for housing is S1. The other grades, S2 and S3, are typically specified for utility buildings. When specifying imported tile it is advisable to order from a reputable U.S. distributor to avoid substandard material. Slate is also classified into two categories: weathering, which can change color as the slate is exposed to the elements; and non-weathering (unfading), which will not discolor significantly.

TECHNIQUES, MATERIALS, TOOLS**1. REPAIR EXISTING SLATE ROOFS.**

As a rule, most slate roofs last about 75 to 100 years. A great number of slate roofs built in the early 1900's are likely to need reroofing due to deterioration of the slate, the flashings, the fasteners, or a combination of all three. The condition of slate roofs can be preliminarily assessed from the ground with the use of binoculars. Critical areas to assess for missing, chipped, cracked, or slipped slates include the ridge, each horizontal row, valleys, and where the roof changes direction. When evaluating a slate roof, note previously repaired areas. Some of these old repairs may not have been done correctly and may need to be reworked. Fasteners and flashings should also be surveyed. Check flashings at valleys, chimneys, dormers, vent pipes, and other roofing protrusions. Check also for the condition of gutters and leaders (on a rainy day for best results). Inspect the attic for structural distress, water stains, rot, or other indications of problems. If there are only a few damaged slates, and if the roof is less than 50 years old, it is likely that replacement slates are available, either salvaged or new that can match the color of the existing roof. Slate replacement is usually a project for an experienced roofer, especially if the damaged slates are in the roof's field—slate can be easily broken by roof traffic and the surface is dangerous to walk on. Inexperienced contractors may recommend the removal of a slate roof when, in fact, it is still serviceable.

In some instances, even when substantial areas have suffered from neglect, slate can be removed, flashings and underlayment repaired, and the salvaged material reinstalled with new slate.

ADVANTAGES: Repairs are cost-effective over small areas. In some instances tiles can be removed and reused.

DISADVANTAGES: Requires experienced contractors. Difficult to estimate costs in advance of doing repair work. Can be very costly. Existing slates may be difficult to match. If large areas need replacement, or if serious leaks develop, postponing replacement may cause damage to the building's structural elements or finishes.

2. REPLACE EXISTING SLATE ROOF WITH NEW SLATE.

Available in a range of colors from gray, blue-gray, black, green, deep purple, red, and variations of these shades, depending on where the material was quarried. Typically available in 1/4- and 3/8-inch thickness, slates can be obtained in up to 2-inch thickness for high-end housing where deep shadow lines are desired. The material is heavy (weighing approximately 7 to 8.5 pounds per square foot) and brittle, requiring careful handling. It is installed by hand using copper or stainless steel roofing nails on minimum 3/4 inch roof sheathing over trusses or rafters at 16 inches o.c. Slate can be installed directly over sheathing, on spaced sheathing (with a moisture barrier), or on battens over sheathing. Most manufacturers supply installation details based on industry standards developed in the 1920s by the now defunct National Slate Association. A new, comprehensive and authoritative guide to installation techniques and materials, *The Slate Book*, is well regarded by industry representatives (see Further Reading). Slate is available in a number of patterns, sizes, shapes, and thickness. A standard layout is shown in Fig. 1., and a custom "French" or hexagonal shape in Fig. 2. The standard layout ensures that a single slate is overlapped by two other slates (Fig. 1). An economy installation employing an absolute minimum overlap and asphaltic underlayments interlaced between slates is sometime encountered (Fig. 3.). This system depends on the underlayment lasting the life of the roof, which is usually unrealistic. An important detail in the design of slate roofs is the use of a cant strip at the eaves to elevate the starter course into the same plane as the rest of the slate on the roof. Without the cant strip the slate will not lie properly and will break. New slate products include a ridge vent designed especially for slate (Top Slate™), manufactured by Peterson Aluminum (Fig. 4), and a new attachment and ventilation system, Fastrack for Slate™, promoted by Slate International, Inc. (Fig. 5).

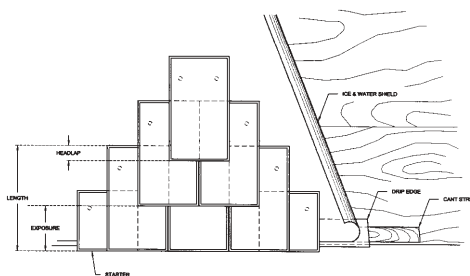

FIGURE 1

STANDARD LAYOUT

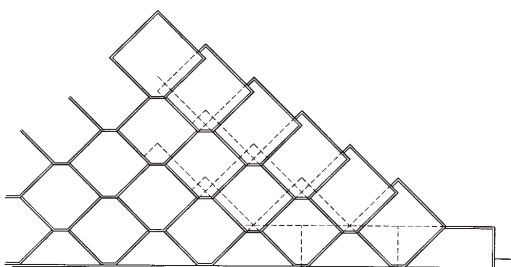

FIGURE 2

"FRENCH" OR HEXAGONAL LAYOUT

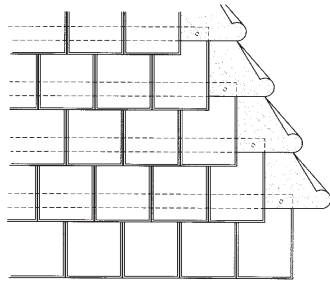

FIGURE 3

ECONOMY INSTALLATION



FIGURES 4,5

TOP SLATE™ RIDGE VENT

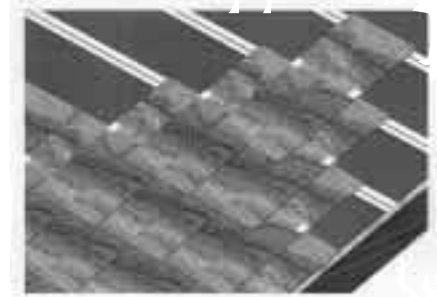

FASTRACK™ FOR SLATE

ADVANTAGES: Very long service life makes slate cost-effective on a life-cycle basis, considering the cost of repeated stripping, removal, and reinstallation of other materials with shorter life spans. Will permanently add to the quality and character of a house. Low maintenance under normal conditions. Individual broken slates are relatively easily replaced by experienced roofers. Noncombustible, impervious to rot, mold, and mildew.

DISADVANTAGES: High initial material and labor cost. Installation prices vary widely depending on availability of qualified roofers and competitive bidding environment. Requires experienced installers. Roof structure may require strengthening to support slate. Some imported slate may be of lesser quality than domestic material, without warranties against fading, discoloration, or delamination. Slate is heavy, brittle, and sharp edges make handling difficult. Corners of slates can be easily chipped. Slate color on existing roofs may be difficult to match.

FURTHER READING

“A Chip Off the Old Slate,” Michael J. Crosbie, *Construction Specifier*, Nov. 1997, pp. 49-54.

Laying Slate, National Slate Association (defunct). Available from Buckingham-Virginia Slate Corp. and other slate manufacturers.

The Repair, Replacement and Maintenance of Historic Slate Roofs—Preservation Brief #29—Technical Preservation Service, National Park Service; www2.cr.nps.gov.

The Slate Roof Bible, Joseph Jenkins, Chelsea Green Publications, 1997; 800-639-4099.

The Slate Book—How to Design, Specify, Install, and Repair a Slate Roof, Brian Stearns, Alan Stearns, and John Meyer, Vermont Slate and Copper Services, Inc.; 1998; 888-766-4273.

The Steep Roof Manual, National Roofing Contractors Association, 1996.

PRODUCT INFORMATION

MANUFACTURERS/SUPPLIERS

Buckingham-Virginia Slate Corp., One Main Street, P.O. Box 8, Arvon, VA 23004-0008; 800-235-8921; www.bvslate.com.

Greenstone Slate, P.O. Box 134, Pultney, VT, 05764; 802-287-4333.

Hilltop Slate Co., Route 22A, P.O. Box 201, Middle Granville, NY 12849; 518-642-2270.

Newfoundland Slate Co. Inc., 8800 Shepard Avenue East, Scarborough, ON, Canada, M1B5R4; 800-975-2835.

Structural Slate Co., 222 East Maine Street, Pen Argyl, PA 18072; 610-862-4145.

DISTRIBUTORS/INSTALLERS

Allied Building Products, Route 17 North, East Rutherford, NJ 07073; 201-935-0800; www.alliedbuildingproducts.com (distributor).

Durable Slate Co., 1050 North Forth Street, Columbus, OH 43201; 800-666-7445 (new and salvaged slate and tile distributor and installer).

Evergreen Slate Co., 68 East Potter Avenue, Granville, NY 12832; 518-642-2530, www.evergreenslate.com (distributor).

New England Slate Co., RDI Burr Pond Road, Sudbury, VT 05733; 888-637-5283; www.neslate.com (distributor of United States, Quebec, and Newfoundland tile).

Roof Tile & Slate Co., 1209 Carroll, Carrolltown, TX 75006; 800-446-0220 (new and salvaged slate distributor).

Slate International, Inc., 15106 Marlboro Pike, Upper Marlboro, MD 20772; 800-343-9785 (distributor).

SNOW GUARDS & SLATE ACCESSORIES

Berger Building Products Corp., 805 Pennsylvania Avenue, Feasterville, PA 19053; 800-523-8852.

Sieger Snow Guard Co., #63 Ziegler Road, Leesport, PA 19533; 610-926-2074 (heavy duty snow guards).

Vermont Slate & Copper Services, Inc., P.O. Box 430, Stowe, VT 05672-0430; 888-766-4273 (heavy duty snow guards).

SLATE RIDGE VENTS

Petersen Aluminum Corporation, 9060 Junction Drive, Anapolis Junction, MD 20701; 800-344-1400.

VENTED ATTACHMENT SYSTEM

Slate International, 15106 Marlboro Pike, Upper Marlboro, MD 20877; 800-343-9875 (Fastrack for Slate™).

CLAY, CONCRETE, FIBER-CEMENT & COMPOSITE TILE

ESSENTIAL KNOWLEDGE

Tile roofing accommodates various building traditions and climatic conditions, and now accounts for over 8 percent of the residential steep-slope roofing market in the U.S. for new construction and about 3 percent for re-roofing. Concrete tile, used mostly in the Southeast, Southwest, and California, now dominates the tile roofing market due primarily to its lower cost. Concrete tile does not have to be baked in a kiln as does clay tile, and the materials for production are more readily available. Fiber-cement and composite shingles are also gaining acceptance because of their lighter weight and lower cost, although some manufacturers have not found these products profitable and have discontinued them.

Roofing tile is differentiated by its shape and composition. Other important characteristics are breaking strength, absorption or porosity, resistance to freeze-thaw, joining methods, and installation details. Clay and concrete roofing tiles are generally available in two shapes: profile and flat. Profile tile can be further divided into pan and cover, S-Tile, and interlocking (Fig. 1). Flat tile can be subdivided into interlocking and non-interlocking. Interlocking is preferred in areas with heavy rains and snow, because it is inherently a more weather-tight system.

PROFILE TILE

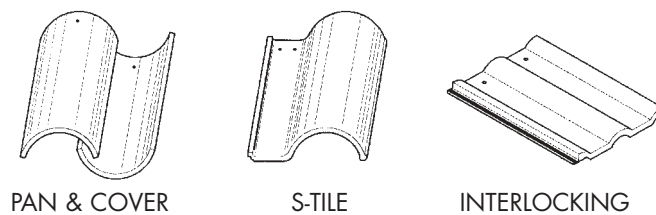

FLAT TILE

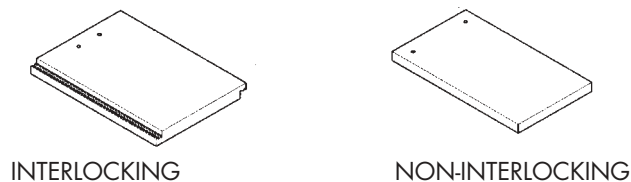

FIGURE 1

The porosity of roof tiles is very important in climates with a repetitive freeze-thaw cycle. The more porous a roof tile is, the more water it will absorb. Water that freezes in a roof tile can cause the material to spall or crack. According to American Society for Testing Materials (ASTM) Standard C 1167 there are three grades of resistance to frost: Grade 1 “Provides resistance to severe frost action;” Grade 2 “Provides resistance to moderate frost action;” Grade 3 “Provides negligible resistance to any frost

action.” The selection of a tile should reflect an appropriate grade. Some fiber cement tiles have delaminated in climates with severe freeze/thaw cycles and most manufacturers will not warrant their products in these areas. The best indication of a roof tile’s durability is a service record of similar tile used in a comparable climate.

The roof installation method should be based upon roof slope, type of roof deck or substrate, climate, seismic considerations, local building codes, and manufacturer’s recommendations. Methods include lug-hung, bedding in mortar, nails, screws, wire, clips, and adhesives. Nails are the least expensive and most widely used installation system. Adhesives outperform mortar bedding in hurricane force winds and are used extensively in Southern Florida. They cost the same as two nails and a hurricane clip, but installation is faster. Adhesives are new on the market so little field knowledge of their durability exists.

TECHNIQUES, MATERIALS, TOOLS

1. REPLACE EXISTING CLAY OR CONCRETE TILES.

The condition of tile roofs can be preliminarily assessed from the ground with the use of binoculars. Critical areas to assess for missing, cracked, or slipped tiles and missing mortar include the ridge, each horizontal row, valleys, and where the roof changes direction. Fasteners and flashings should also be surveyed. Check flashings at valleys, chimneys, dormers, vent pipes, and other roofing protrusions. Check also for the condition of gutters and leaders (on a rainy day for best results). Faulty gutters and leaders will direct water onto roof and wall surfaces which were not designed for high water flows. These areas should be inspected carefully for damage and deterioration. Inspect the attic for water stains, rot, or other indications of problems. If there are only a few damaged tiles, and if the roof is less than 100 years old, it is likely that replacement tiles are available and individual tiles can be replaced. This is usually a project for an experienced roofer, especially if the damaged tiles are in the roof’s field, because tiles can be easily broken from roof traffic and the surface is dangerous to walk on. The isolated replacement of a few tiles is relatively easy, but for more extensive work, a contractor experienced in the installation and maintenance of tile should be engaged (suppliers of roofing tile can frequently be a good referral source). Inexperienced contractors may recommend the removal of a tile roof when, in fact, it is still serviceable. In some instances, even when substantial areas have suffered from neglect, tiles can be removed, flashings and underlayment repaired, and the tiles reinstalled with new tiles placed in areas where they are less visible.

ADVANTAGES: Repairs require more skill than other roof materials, but are cost-effective over small areas. In some instances tiles can be removed and reused.

DISADVANTAGES: Requires experienced contractors. Difficult to estimate costs in advance of doing repair work. Can be very expensive. Existing tile may be difficult to match.

2. INSTALL NEW CLAY ROOF TILE.

Because of the long service life of clay tile, it is recommended that a high performance underlayment be installed. Clay roof tiles come in a variety of colors in both earth tones and glazed primary colors. Unlike some other roofing products, clay roof tiles maintain their color over time. Celadon Ceramic Slate produces a clay tile that weighs 580 pounds per square. This product looks like slate, and costs around \$220 to \$260 per square. Costs are a function of tile size, and the manufacturer’s production volume and processes. On a per square basis, smaller tiles cost more to purchase and install than large tile.

ADVANTAGES: Traditional roofing material. Comes in a variety of types and styles (Fig. 2) Perceived as a high end, quality construction material. Long lasting and virtually maintenance free. Fireproof and impervious to insects and rot. Will withstand hurricane winds better than other roofing products, and many resist the effects of freeze-thaw cycles.

DISADVANTAGES: More difficult to install than other roofing products. Not recommended for roofs with less than a 4-in-12 pitch. Heavy, can weigh anywhere from 520 to 1,250 pounds per square. Additional roof supports may be needed for existing roofs before installing clay tile roofs. Clay roofing tile has a high first cost ranging from \$180 to \$1,800 per square. Due to the limited number of clay roofing tile manufacturers, the material may have to be shipped long distances, increasing costs dramatically.

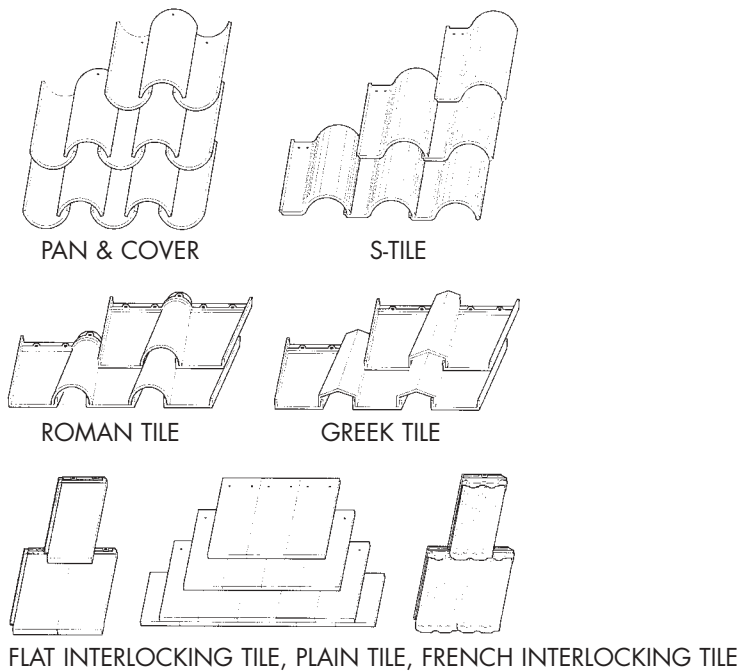

FIGURE 2

CLAY TILES

3. INSTALL NEW CONCRETE ROOF TILE.

Concrete tile makes up about 6 percent of the U.S. residential steep-slope roofing market, with California representing the largest market. Studies show that concrete tile life-cycle costs are significantly less than other roofing products. Because of the long service, it is recommended that a high performance underlayment be installed. The Southeast is particularly vulnerable to the underlayment cracking due to high levels of heat and humidity. Concrete tile comes in a variety of shapes, colors, and textures, simulating clay roof tile (Fig. 3) as well as wood shakes and slate. The material typically weighs 1,000 pounds per square, although Westile's FeatherStone® product weighs 690 pounds per square (costs 30 percent more than its standard tile).

ADVANTAGES: Generally less expensive than clay tile. Long lasting, estimated 40 to 50 years in California and

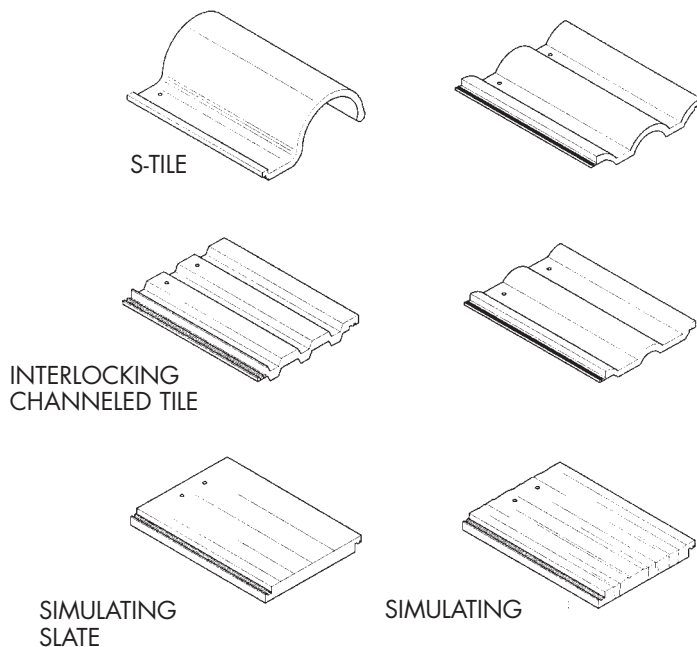

FIGURE 3

CONCRETE TILES

the Southwest, and 20 to 30 years in the Southeast. Fireproof, can withstand insects, rot, and hurricane winds better than other roofing products. Some products are designed to resist the effects of freeze-thaw cycles. **DISADVANTAGES:** More difficult to install than other roofing products. Not recommended for roofs with less than a 4-in-12 pitch. Has a high first cost, three times the cost of asphalt shingles and 150 percent that of cedar roofing. Because of the limited number of concrete tile manufacturers, the material may have to be shipped, raising the cost dramatically. Existing roofs may require additional support. Sealant covered roof tile will change from a glossy to a mat finish as the sealant wears off.

4. INSTALL NEW FIBER-CEMENT ROOF TILES.

Fiber-cement shingles are made from a blend of portland cement, synthetic or natural wood fibers and, on occasion, lightweight aggregate. The material can simulate natural slate and wood shakes. One product, Cembrit B7, is made in 24- by 93-inch panels that simulate clay barrel tiles. There is conflicting information about which manufacturing process produces the most durable product. Some manufacturers claim that the steam-curing autoclave process increases the strength and durability of fiber cement while greatly reducing water absorption. Others claim this creates a more brittle product than air-cured fiber cement, and is more likely to break from seismic stresses or when walked on. Air-cured products are pressed to increase density and therefore reduce absorptivity. Fiber-cement roofing is available with a manufacturer's warranty of from 25 to 60 years. Some manufacturers are finding that fiber-cement production is not profitable. GAF Materials Corporation has recently discontinued sales of its roofing product, UltraSlate® and American Cemwood Corporation has also discontinued its fiber-cement roofing products, Cascade® and Royal® shakes and Pacific® slates.

ADVANTAGES: Lighter and can be less costly than clay or concrete roofing tile. Some products can be installed over asphalt shingles. Will not rot, split, or curl. Material can be cut with a saw and fastened with conventional fasteners. Simulates quite accurately the texture of shakes and especially slate.

DISADVANTAGES: Fiber-cement shingles are more porous than cement and clay tiles and may crack or delaminate in repeated freeze-thaw cycles. The appropriateness of specific products for use in cold climates should be confirmed with the manufacturer. Repeated dry-wet cycling could also cause some products to deteriorate. May appear different from the products they simulate. Some fiber-cement products are susceptible to breakage from foot traffic and should not be used for recover applications. Not recommended for slopes with less than 4-in-12 pitch.

5. INSTALL NEW COMPOSITE ROOF SHINGLES.

In a process parallel to the development of fiber-cement shingles, some manufacturers now make products that are composites of various materials. One such product from Owens Corning, MiraVista™ shake shingle, is made of slate and clay reinforced with fiberglass and bonded under pressure with polymeric resin.

ADVANTAGES: Configured with rough texture, uneven shape and detailing that is quite similar in appearance to wood shakes. Lightweight, available in natural, non-fading colors that will weather to a natural looking weathered tone. Lightweight, Class A rating, will not absorb water. Installs like wood shakes. Competitively priced with fiber-cement.

DISADVANTAGES: New product without history of durability. May not be available nationally. May appear different from the products they simulate.

6. INSTALL NEW PLASTIC COMPOSITE ROOF TILES.

A number of new plastic composite products have become available recently, including Eco-Shake®, made from recycled pallet wood, shower curtains, and plastic bottles; Authentic Roof Shakes® made from 100% post-consumer waste; and Perfect Choice® 21- by 40-inch molded panels of Noryl plastic made to look like 13 individual hand-split shakes.

ADVANTAGES: Very lightweight, easy and fast to install with conventional fasteners. Appearance is reasonably close to shakes and tiles. Wind and hail resistant. Recycled content makes it environmentally sound.

DISADVANTAGES: Most materials have class C ratings; new untested materials; may require special cutting equipment. May not have model code approvals. May appear different from the products they simulate.

FURTHER READING

“Alternative Roofing Materials,” *Journal of Light Construction*, August 1997, pp. 33-37.

“Choosing Roofing,” *Fine Homebuilding*, Jan. 1995, Volume 92, pp. 46-51.

“Clay in Context,” Mary Ellen Polson, *Old Home Journal*, April 1998, pp. 39-43.

“Roofing Materials: A Look at the Options for Pitched Roofs,” *Environmental Building News*, Vol. 4, No. 4, July/August 1995.

“Stu’s Tile Talk,” Northern Roof Tile Sales, Blasdell, NY.

The NRCA Steep Roofing Manual, National Roofing Contractors Association, Rosemont, IL.

“The Top Choice,” National Tile Roofing Manufacturer’s Association, Eugene, OR.

PRODUCT INFORMATION

National Tile Roofing Manufacturers Association, P.O. Box 40337, Eugene, OR 97404; 541-689-0366.

CLAY TILE

Altusa Tile, 6645 Northwest 77th Avenue, Miami, FL 33166; 305-471-5830; www.altusa.com.

Ameri-Clay Roof Tile, 2905 47th Avenue, North, St. Petersburg, FL 33714-3131; 813-522-3900; www.americlay.com.

Celadon, P.O. Box 309, New Lexington, OH 43764-0309; 800-235-7528; www.celadonslate.com.

Gladding, McBean, P.O. Box 97, 601 Seventh Street, Lincoln, CA 95648; 800-776-1133; www.gladding-mcbean.com.

Ludowici Roof Tile, P.O. Box 69, 4757 Tile Plant Road, New Lexington, OH 43764; 800-945-8453; www.ludowici.com.

Maruhachi Ceramics of America, Inc. (MCA), 1985 Sampson Avenue, Corona, CA 91719; 800-736-6221; www.mca-tile.com.

U.S. Tile Company, 909 West Railroad Street, Corona, CA 91720; 909-737-0200; www.ustile.com.

SALVAGED AND NEW CLAY TILE

Renaissance Roofing, Box 5024, Rockford, IL 61125; 800-699-5695; <http://members.ad.com/roof-tiles/home.html>.

The Roof Tile and Slate Co., 1209 Carroll, Carrollton, TX 75006; 800-446-0220.

Tile Roofs Inc., 12056 South Union Avenue, Chicago, IL 60623; 708-479-4366.

Tilesearch, P.O. Box 1694, Roanoke, TX 76262; 817-491-2444.

The Tile Man, Inc., 520 Vaiden Rd., Louisberg, NC 27549; 919-853-6923; www.thetileman.com.

CONCRETE TILE

Boral Life Tile, Inc., 4685 MacArthur Court, Suite 300, Newport Beach, CA 92660; 800-LIFETILE; www.lifetile.com.

Columbia Concrete Products, Ltd., 8704 120th St., Surry, British Columbia, Canada V3W 3N7; 604-596-3388; www.crooftile.com.

Eagle Roofing Products Co., 3546 North Riverside Ave., Rialto, CA 92376; 909-355-7010; www.eagle-roofing.com.

Entegra Roof Tile Corp., 1201 Northwest 18th Street, Pompano Beach, FL 33069; 800-586-7663.

Metro Roof Tile, Inc., 11501 Northwest 117th Way, Medley, FL 33178; 305-863-0021.

Monier Lifetile LLC, One Park Place, Suite 900, Irvine, CA 92714; 714-756-1605.

Pioneer Roofing Tile, Inc., 10650 Poplar Ave., Fontana, CA 92337; 909-350-4238; www.piotile.com.

Vande Hey-Raleigh, 1665 Bohm Drive, P.O. Box 263, Little Chute, WI 54140; 800-236-8453; www.vhr-roof-tile.com.

Westile, 8331 West Carder Court, Littleton, CO 80125; 800-433-8453; www.westile.com.

FIBER-CEMENT TILE

California Shake Company, 5355 North Vincent Avenue, Irwindale, CA 91706; 818-969-7544 (Cal-Shake® and Cal-Slate®).

Eternit, Excelsior Industrial Park, P.O. Box 679, Blandon, PA 19510-0679; 800-233-3155 (Eternite Slates®).

FireFree, P.O. Box 1094, Sumas, WA 98295; 800-347-3373 (FireFree®).

James Hardie Building Products, 26300 La Alameda, Suite 250, Mission Viejo, CA 29691; 800-942-7343; www.JamesHardie.com (Hardishakes®).

Louisiana-Pacific Corp., 111 Southwest Fifth Avenue, Portland, OR 97204; 800-579-8401; www.lpcorp.com (Nature Guard®).

Northern Roof Tile Sales Co., 4408 Mile Strip Road, Suite 266-Blasdell, NY 14219, 905-627-4035 (Cembrit B7).

COMPOSITE TILE

American Sheet Extrusion Corporation, 1618 Lynch Road, Evansville, IN 47711; 800-347-3390 (Perfect Choice® plastic shake).

Crowe Industries, Ltd, 116 Burris Street, Hamilton, Ontario L8M 2J5; 905-529-6818 (Authentic Roof® plastic slates).

Owens Corning, One Owens Corning Parkway, Toledo, OH 43659; 800-766-3464; www.housenet.com, (MiraVista™ shakes).

Re-New Wood, P.O. Box 1093, Waggoner, OK 74467; 800-420-7576 (ECO-Shakes® wood and plastic shake).

FOREIGN-MADE TILE

HG Roofing and Consulting, P.O. Box 406, Lakeville, IN 46536; 219-784-2006.

Northern Roof Tile Sales Co., Inc., 4408 Mile Strip Road, Suite 266, Blasdell, NY 14219; 905-627-4035.

13

GUTTER AND LEADER SYSTEMS

ESSENTIAL KNOWLEDGE

The purpose of gutter and leader (downspout) systems is to collect rainwater from the roof and direct it away from the building foundation by means of leader extensions, splash blocks, or underground drain lines. An improperly functioning gutter and leader system can contribute to water and ice backing up against fascias and under roof shingles, can damage soffits, and can discolor or deteriorate siding materials. Faulty gutters and leaders can also lead to soil erosion adjacent to buildings and serious water and foundation displacement problems in basements and crawl spaces. Unfortunately, gutter systems take more abuse from extreme weather conditions, particularly ice and snow, than any other component of the building envelope. They are also subject to damage from ladders and being stepped on, as well as from falling tree limbs and debris.

Gutters should be sloped a minimum of 1 inch for every 40 feet of run. Standing water may indicate a sagging or incorrectly pitched gutter. Gutters are often sized according to the roof area they drain. Five-inch-wide K-style gutters are the residential industry's standard. Six-inch-wide K-style gutters are used for larger roofs. Half-round gutters are typically sized 1 inch wider than K-style to provide the equivalent capacity. Therefore, 6-inch half-round gutters are equivalent to 5-inch K-style. Four-inch-wide K-style and



K-STYLE

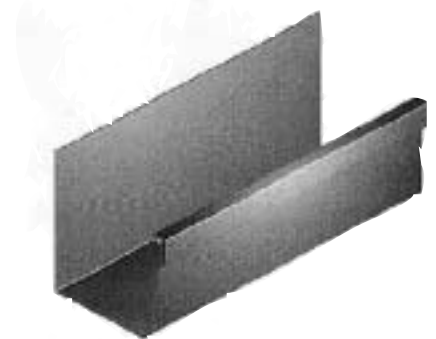

SQUARE (BOX)



HALF-ROUND

FIGURES 1,2

FIGURE 3

5-inch half-round gutters (with equivalent capacity) are rarely used except for small roofs. Wider gutters may be required for certain hard surface roofing materials, such as slate and tile, or used on steeply-pitched roofs, to prevent water from shooting over the gutter. Gutters should be positioned tight against roofing materials and the fascia. In heavy snow areas, snow guards should be used to prevent gutter tear-off.

Vertical leaders (downspouts) are used to capture and distribute rain water to storm drainage systems, or by means splash blocks, to areas away from the building's foundation walls to prevent the build up of water in the soil and possible resulting structural or basement moisture problems. Leaders are typically rectangular and of the same material as the gutter to prevent destructive galvanic actions. Connections between gutters and leaders and leaders and storm drains require continuing maintenance to assure the drain is free of leaves and debris and the connection has not become loose. Other maintenance points include the connections of leaders to the building. Leader diameters are sized according to the roof area they drain. A rule of thumb used in the industry is that a 2- by 3-inch leader will suffice for a 600 sq. ft. roof and a 3- by 4-inch leader for 1,200 sq. ft. The typical leader size for a 5-inch K-style gutter is 2 by 3 inches, but 3 by 4 inches is preferable because it is less likely to become clogged and is easier to clean out.

Before 1960, most gutters were made of wood or metal in a "half-round" shape. During the 1960s, roll-formed metal gutter technology was introduced that allowed metal gutters to be made lighter and less expensively. Initially available primarily in galvanized steel, roll-formed gutters are now available in copper, aluminum, galvanized, and painted steel. Gutter profiles include half-round and square, but the K-style (also called formed, Ogee, or OG) (Figs. 1,2,3) predominates because it is visually compatible with recently-built housing and adds interest to simple fascia details. Recent developments in truck-mounted roll-forming equipment have allowed gutter installers to form continuous, seamless metal gutters to fit site-measured field dimensions and individual roof profiles. Other recent developments include the use of vinyl (PVC) snap-together gutter systems used primarily in the rehab/do-it-yourself market because of their ease of installation. Another relatively new product, Rainhandler™ claims to eliminate the need for gutters by deflecting rain away from the building (Fig. 4). Each gutter system has its own special characteristics and uses.

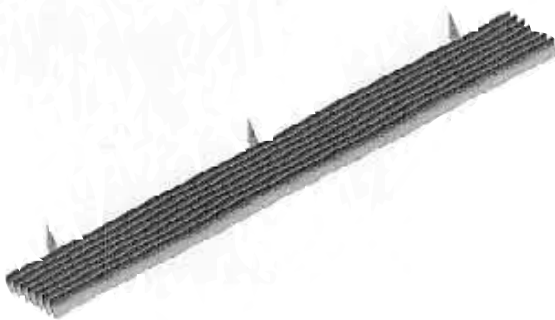

FIGURE 4

RAINHANDLER™

TECHNIQUES, MATERIALS, TOOLS

1. REPAIR EXISTING GUTTER SYSTEMS.

Other than keeping gutters clean of leaves, pine needles, and debris, gutter maintenance usually involves refastening hangers that have become unfastened, repairing broken hangers, or adding new hangers where hanger spacing was excessive. Hangers come in a variety of types, including hanger and strap, hanger and bracket, spike and ferrule, and concealed hanger (Figs. 5,6,7,8). The spike and ferrule, because it fastens through the gutter, is more apt than other hanger types to pull out of the fascia due to expansion and contraction of the gutter. Concealed fasteners are becoming increasingly popular because they are easy to install, are not visible, are relatively strong, allow the gutters to expand and contract, and come in a variety

of sizes and configurations with different screw and nail attachment details. Other maintenance and repair items include keeping gutter and downspout screens in place, refastening leaders, and maintaining splash blocks or connections to underground drains. Gutters deteriorate over time — wood gutters need to be oiled, metal gutters may need local repairs. At some time, usually when new roofing is required, the gutters may have weathered to the point where they are not functioning, are unsightly, or have significantly deteriorated. The choice of a replacement will be dictated by the appearance, value, physical characteristics, and age of the existing house.

ADVANTAGES: Repairs are generally easy to make and are cost-effective if the damage is localized.

DISADVANTAGES: When gutter systems show wide-spread deterioration and become unsightly, they should be replaced in their entirety.



FIGURES 5,6 HANGER AND BRACKET (FASTENER)

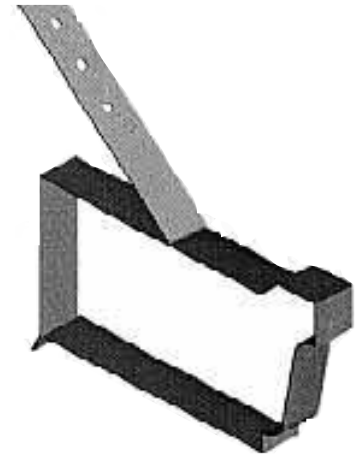

HANGER AND STRAP (FASTENER)



FIGURES 7,8 SPIKE AND FERRULE (FASTENER)

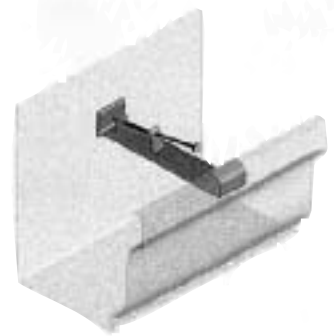

CONCEALED (FASTENER)

2. INSTALL NEW WOOD GUTTERS AND LEADERS.

Wood gutters are still a favorite for some traditional homes. Typically available in a 4 by 6 inches in clear fir, gutters can also be milled from cedar or redwood. One supplier, Blue Ox Millwork, offers redwood gutters in any one of 16 standard patterns or can customize to suit. The company recommends a scarfed joint with both sides of the splice beveled $\frac{1}{4}$ inch on the inside to allow a depression to be filled with butyl or other high-quality sealant. The sealant can be cut out and replaced when it fails (Fig. 9). The interior leg of a gutter should be $\frac{1}{8}$ to $\frac{1}{4}$ inch higher than the outside leg in order to spill water outward. Blue Ox recommends that, in lieu of lining gutters, a product called Chevron Shingle Oil be used in the gutter's interior. This product will prolong gutter life by reducing the weathering while at the same time allowing the gutter to breathe. Other products, including single-ply roofing membranes, are available that can be



FIGURE 9

SCARFED JOINT

used to line new or deteriorated wood gutters. One of these, Deck Seal®, a SBS rubberized asphalt membrane, as offered in 1.5-, 3.5-, and 6-inch rolls (see Product Information). Leaders, which can be copper, black iron, or PVC, are attached to the gutter by means of a nipple screwed into the gutter's interior. Some traditionalists recommend boxing (enclosing) the leaders with wood to conceal the metal leader.

ADVANTAGES: Appropriate for more traditional housing or where the “shingle style” predominates. A strong, straight material that provides a crisp edge detail. Properly maintained, fir can last 50 years or more and redwood twice that. The front face can be painted to match adjacent trim.

DISADVANTAGES: May not be readily available in some areas. More costly initially than other alternatives (redwood gutters are approximately \$10 to \$12/lineal ft. for 4 by 4 inches (used on West Coast) and \$16 to \$18 for 4 x 6 inches (plus \$175 set up). Fir gutters are approximately \$10/lineal ft. Gutters and leaders require maintenance to prevent wood from drying out and checking. Heavier than other gutter materials. Not typically the choice for non-custom housing.

3. INSTALL NEW STEEL GUTTERS AND LEADERS.

Steel gutters and leaders are available in a variety of styles, including K-style, square (box gutters), and half-round. Available materials include electroplated and hot-dipped galvanized and Galvalume® (approximately 55 percent aluminum, 45 percent zinc by weight). Finishes also include plain galvanized, baked enamel, modified siliconized acrylic and polyester, and fluoropolymer coatings such as Kynar. Gauges run from a lightweight 28 ga. to heavier 24 ga., with 26 ga. being the most typical. Gutter assemblies include “stick” systems of components sold through lumber yards or home centers (Fig. 10) with typically 10- to 20-foot gutter lengths, for installation by homeowners or small contractors, as well as seamless systems provided by installers with truck-mounted roll-formers. While both stick and seamless

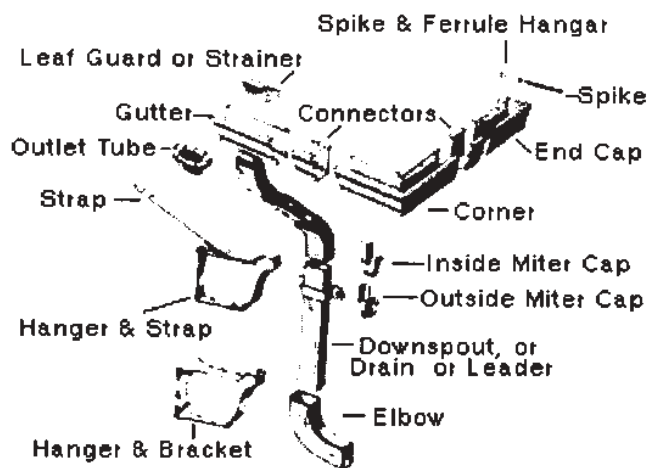

FIGURE 10

“STICK” SYSTEM

systems can work satisfactorily, seamless systems have fewer joints, are apt to leak less, and are faster to install. Stick systems are, however, apt to be less expensive on single houses or small projects.

ADVANTAGES: Steel is stronger than aluminum at equivalent thickness and contracts one-half as much. Some newer coating systems allow limited guarantees up to 50 years. Steel is popular in Northern states with snow and ice conditions.

DISADVANTAGES: Some galvanized finishes have a limited life span (5-10 years). Hot-dipped galvanized gutters are preferred over other galvanized finishes, but are not recommended for maritime environments unless the coil has been pre-coated. Galvanized finishes are rarely cleaned or primed properly and when field painted, the paint can fail prematurely.

4. INSTALL NEW K-STYLE ALUMINUM GUTTERS.

Aluminum gutters and leaders are by far the most popular gutter systems. Available in a variety of styles, including K-style, half-round, and a K-style modified to replace a fascia board (Fig. 11). Coatings include baked enamel, polyester, and acrylic. Gutter thicknesses run from a lightweight 0.019 to a heavier 0.032 inch, often specified on higher-end housing. The most typical thickness is 0.027 inch. Thicknesses below 0.027 inch are sometimes used on low-end housing and are available through price-sensitive home centers for the do-it-yourself markets. Aluminum gutters are available “stick” style and seamless, with the latter being more common, especially on larger projects. “Stick” systems are frequently offered in greater thicknesses than seamless (0.032 versus 0.027 inch) and are stronger. The benefit of seamless systems is the lack of joints (which are points of potential leaks if not maintained). Concealed hangers are becoming more popular because they are invisible and allow the gutter to expand and contract. Expansion and contraction at bracket support types that surround the gutter can lead to discoloration and wear at those points. Spike and ferrule fittings are sometimes unsightly due to sloppy installation, and can pull out of the fascia from the significant movement of aluminum resulting from temperature swings.

ADVANTAGES: Widely available. Low cost, and relatively easily maintained. Comes as both “stick” and seamless in many color options. Easily installed. Long-term warranties on coatings are common.

DISADVANTAGES: Expands twice as much as steel and 50 percent more than copper. Less strong than steel or copper. Can be dented (especially in lighter thickness) more easily than other gutter materials.



FIGURE 11

K-STYLE AND FASCIA

5. INSTALL NEW K-STYLE COPPER GUTTERS.

Copper has been a traditional gutter material for institutional buildings and large houses and continues to be popular for high-end custom housing. Typically specified in 16 or 20 ounces, K-type or in half-round styles up to 8 inches wide, copper is available in “stick” as well as seamless systems. Copper has also been used as sheet flashing in “boxed” or built-in gutters (Fig. 12). Typically allowed to weather naturally, copper develops a blue-green coloration resulting from the formation of a protective copper oxide patina. Lead-coated copper gutters are also available from some suppliers for those preferring a grey color.

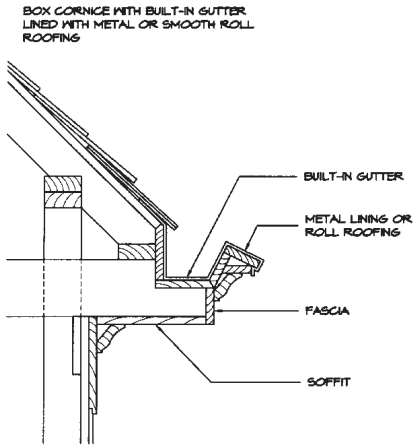

FIGURE 12

BOX CORNICE WITH BUILT-IN COVER

According to the Copper Development Association, copper gutters are affected by the acids in red cedar shingles only to the extent that the acid may retard patination. Pitting of the gutter will not occur if recommended details are followed (see Further Reading). Copper joints and connections are usually soldered, providing continuous surfaces, which limit the potential for leaks.

ADVANTAGES: Considered a quality, premium product. An appropriate material for historic preservation projects. Copper patina blends well with many roofing products. Low maintenance, does not require paint. Will not rust and is well suited for maritime environments.

DISADVANTAGES: Significantly more costly than alternative materials. Requires skilled installers for cutting and soldering of joints and transitions. Not a normal choice for other than custom applications.

6. INSTALL NEW HALF-ROUND COPPER & ALUMINUM GUTTERS.

Half-round gutters were the traditional gutter style on homes built before 1950 and remain a popular choice on historic renovation projects, traditional renovations, and new upscale custom housing. The simple lines of half-round gutters compliment heavily textured materials such as slate, shakes, and tiles. Where crown moldings exist in lieu of fascias, half-round gutters are hung from the roof. Where fascia exist, fascia brackets are used to attach gutters. One company, Classic Gutter Systems, sells specially designed oversized 5- or 6-inch half-round gutters made of heavy weight 20 ounce copper and heavy weight .032 aluminum. They supply an extremely durable hanging systems as well as heavy weight cast brass and aluminum functional brackets in decorative and plain styles (Fig. 13). These are lag bolted with stainless-steel lags into the fascia board. A full line of accessories, decorative components, and screens is also available.

ADVANTAGES: Half-round gutters are the most efficient gutter shape and least affected by ice and snow. Appropriate for both historic rehabilitation and new construction, both contemporary and traditional. Attractive and durable.

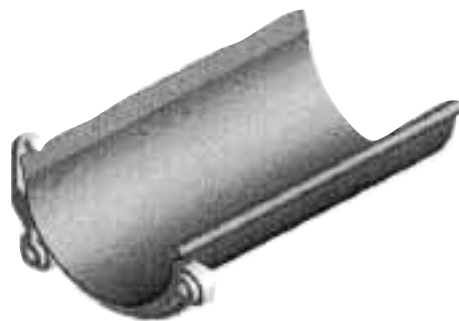

FIGURE 13

HANGING SYSTEM

DISADVANTAGES: Higher initial material cost than some other gutter products. Approximately \$2.25 to \$2.75 for aluminum and \$5 to \$5.50/lineal foot for copper (not including hardware — direct from Classic Gutter Systems). Not generally used on non-custom housing.

7. INSTALL NEW VINYL (PVC) GUTTERS.

Originating in Europe, vinyl gutter systems have a small but growing following, largely among do-it-yourselfers. One U.S. company, Plastmo, has been the leading supplier of vinyl gutters in Scandinavia since 1959. Gutters can run the gamut from flexible to quite strong depending on the material's thickness, that runs from 0.062 to 0.089 inch. Its great appeal is its snap-together simplicity and the limited number of tools required to cut and assemble it. Vinyl gutters are available in K-style, contemporary (“U” shapes), and half-round styles. One small manufacturer has a half-round gutter system that can be emptied from the ground by means of a hooking device that engages a gutter that rotates on its support brackets allowing leaves and debris to fall out (see Product Information).

ADVANTAGES: Strong and resists dents. Will not rust, chip, or peel. Lightweight and low maintenance. In use for over 35 years. Available direct from some manufacturers and at most home centers. Effective in corrosive environments. Low cost. Easy to assemble. Can be painted if necessary.

DISADVANTAGES: Gutter stock is only available in 10-foot lengths. Visually different from more traditional gutter systems. Basically a do-it-yourself technology, with most gutter contractors committed to aluminum and/or steel because of their investment in those systems. Perceived by some to be a lower-end product. Limited number of colors.

8. REPLACE/PROVIDE GUTTER SCREENS/GUARDS.

A variety of products are available to retard the build-up of leaves, twigs, dirt, and asphalt roofing granules in gutters. Historically these have been galvanized or vinyl-coated metal or plastic screening material, but recently a host of “gutter guard” products has emerged. These products range from slotted or perforated vinyl or metal extrusion to nylon mat filters. Additionally, some manufacturers and distributors of roll-forming equipment and metal coils have produced gutters that include protective hoods. One manufacturer, Englert, Inc., fabricates and sells through franchised dealers a 0.032-inch aluminum gutter called Leaf Guard™ that incorporates a hood (Fig. 14). The Leaf Guard™ system is guaranteed against the need to be cleaned for 20 years (or the dealer clears it). The system is claimed to be strong and to resist snow and ice damage. The cost is over three times that of conventional gutter systems. Another new system developed by Knudson Manufacturing Inc. called K-Guard™ is made from 0.027-inch aluminum, has a similar profile to Leaf Guard®, but has a snap-in top that can be opened for cleaning (Fig. 15). The other gutter guard systems are typically aluminum “hats” that cover the gutter and allow water to run down through slots at the gutter's front edge. One manufacturer, DCI Products and Services, produces a nylon mat that covers the top of the gutter trough, but allows water through (Fig. 16).

ADVANTAGES: Reduces need and danger of inspecting gutters. Generally keeps leaves, twigs, and other debris out of gutters. Performs satisfactorily in light to moderately heavy rains. Some products guaranteed for 20 years against debris build-up. Designed to be self-flushing with 3 by 4-inch leaders.

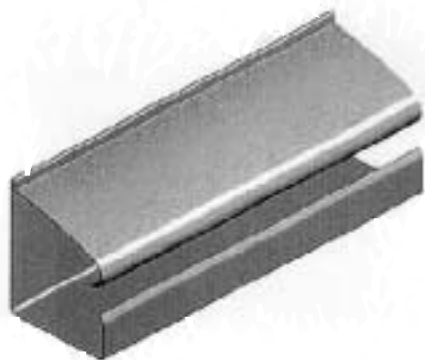

FIGURE 14

LEAF GUARD™



FIGURE 15

K-GUARD™



FIGURE 16

GUTTER GUARD

DISADVANTAGES: Do not keep out all small twigs, dirt, asphalt roofing granules, and pine needles. Perform less well in very heavy rains or on steep roofs. May not be considered visually appealing. Difficult to remove gutter guards to access gutters.

FURTHER READING

“Copper in Architecture Handbook,” Copper Development Association, Inc., www.copper.org.

“Gutters, Flashing and Roof Details” video, Copper Development Association, Inc., www.copper.org.

“Architectural Sheet Metal Manual,” Sheet Metal and Air Conditioning Contractors National Association (SMACNA), www.smacna.org.

PRODUCT INFORMATION

WOOD GUTTERS

Blue Ox Millworks, 1X Street, Eureka, CA 95501-0897; 800-248-4259 (redwood gutters).

ALUMINUM GUTTERS

Alcoa Building Products, Box 3900, Peoria, IL 61612; 800-962-6973, www.alcoahomes.com (stick systems).

Berger Building Products, 805 Pennsylvania Boulevard, Feasterville, PA 19053; 800-523-8852, www.bergerbros.com.

Classic Gutter Systems, 5621 East "D.E." Avenue, Kalamazoo, MI 49004; 616-382-2700 (half-round aluminum gutters and accessories).

Custom-Bilt Metals (corporate office), 9845 Joe Vargas Way, South El Monte, CA 91733; 800-826-7813.

STEEL GUTTERS & ACCESSORIES

Berger Building Products, 805 Pennsylvania Blvd., Feasterville, PA 19053; 800-523-8852.

Custom-Bilt Metals (corporate office), 9845 Joe Vargas Way, South El Monte, CA 91733; 800-826-7813.

Klauer Manufacturing, P.O. Nox 59, Dubuque, IA 52004-0059; 319-582-7201 (stick systems).

COPPER GUTTERS & ACCESSORIES

Berger Building Products, 805 Pennsylvania Blvd., Feasterville, PA 19053; 800-523-8852, www.bergerbros.com.

Classic Gutter Systems, 5621 East "D.E." Avenue, Kalamazoo, MI 49004; 616-382-2700, (half-round gutters and accessories).

VINYL (PVC) GUTTER SYSTEMS

Bemis Manufacturing Co., 300 Mill Street, Sheboygan Falls, WI 53005-0901; 800-558-7651, www.bemismfg.com, (K-style and "U" shaped).

Genova Products, Inc., 7034 East Court Street, Davison, MI 48423; 800-521-7488, www.genovaproducts.com, (K-style and "U"-shaped gutters and vinyl gutter guards).

GSW Thermoplastic Co., 1735 Highwood E., Building J, Pontiac, MI 48340; 800-662-4479, (K-style and "U"-shaped gutters and accessories).

Plastmo Vinyl Raingutters, 8246 Sandy Court #B, Jessup, MD 20794; 800-899-0992, (K-style and half-round systems).

Tilt 'N Clean, Rain Gutter Systems™, 280 Kenwood Drive, Wayne, PA 19087; 800-454-TILT, (half-round gutter systems that can rotate for cleaning from the ground).

GUTTER GUARD PRODUCTS

FLO-FREE™, DCI Products and Services, Sycamore & Mill Street, Clifton Heights, PA 19018; 800-622-4455, www.flofree.com.

Gutter Helmet™, American Metal Products, 8601 Hacks Cross Road, Olive Branch, MS 38654; 800-423-4270.

Gutter ProTech™, Absolute Gutter Protection, P.O. Box 568, Woodbury, NJ 08096-7568; 800-283-7791.

Gutter Topper™, Gutter Topper Ltd., P.O. Box 349, Amelia, OH 45102; 800-915-5888.

Waterfall®, Crane Plastics Co., 2141 Fairwood Avenue, Columbus, OH 43207; 800-307-7780, www.crane-plastics.com.

GUTTER-LESS DEFLECTING SYSTEMS

Rainhandler™, Savetime Corporation, 2710 North Avenue, Bridgeport, CT 06604; 800-942-3004.

CONCEALED GUTTER HANGERS

White Oak Manufacturing, LLC, 809 Glenwood Drive, Ephrata, PA 17522; 800-245-4086.

SHINGLE OIL

Chevron Products Company, Global Lubricants, 1716 South 5th Street, Louisville, KY 40208; 800-LUBETEX, www.chevron.com.

GUTTER LINERS

Heckman Industries, 405 Spruce Street, Mill Valley, CA 94941; 800-841-0066.

SNOW GUARDS AND ROOFING ACCESSORIES

Berger Building Products, 805 Pennsylvania Boulevard, Feasterville, PA 19053; 800-523-8852; www.bergerbros.com.

Vermont Slate and Copper Services, Inc., P.O. Box 430, Stowe, VT 05672; 888-SNOGARD; www.CAD-SPEC.com.

APPENDIX

PROFESSIONAL ASSOCIATIONS & RESEARCH CENTERS

AMERICAN INSTITUTE OF TIMBER
CONSTRUCTION
7012 South Revere Pkwy, Suite 140
Englewood, CO 80112
303-792-9559
www.aitc-glulam.org

APA—THE ENGINEERED WOOD ASSOCIATION
P.O. Box 11700
Tacoma, WA 98411-0700
253-565-6600
www.apawood.org

AMERICAN GALVANIZERS ASSOCIATION
12200 East Iliff Avenue, Suite 204
Aurora, CO 80014
303-750-2900
www.galvanizeit.org

AMERICAN IRON AND STEEL INSTITUTE
1101 17th Street, N.W., Suite 1300
Washington, DC 20036-4700
800-79-STEEL
www.steel.org

AMERICAN NATIONAL STANDARDS INSTITUTE
11 West 42 Street, 13th Floor
New York, NY 10036
212-642-4900
www.ansi.org

AMERICAN SOCIETY OF HEATING,
AIR CONDITIONING, AND
REFRIGERATION ENGINEERS
1791 Tullie Circle, N.E.
Atlanta, GA 30329
404-636-8400
www.ashrae.org

AMERICAN SOCIETY FOR TESTING AND
MATERIALS
100 Barr Harbor Drive
West Conshohocken, PA 19428
610-832-9500
www.astm.org

AMERICAN SOCIETY OF CIVIL ENGINEERS
1801 Alexander Bell Drive
Reston, VA 20191-4400
800-548-2723
www.asce.org

AMERICAN WOOD COUNCIL
1111 19th Street, NW
Washington, DC
800-292-2372
www.awc.org

ASPHALT ROOFING MANUFACTURERS
ASSOCIATION
4041 Powder Mill Road, Suite 404
Calverton, MD 20704-3106
301-231-9050
www.asphaltroofing.org

ASSOCIATED SHEET METAL & ROOFING
CONTRACTORS
One Regency Drive
P.O. Box 30
Bloomfield, CT 06002
860-243-3977

BUILDING SEISMIC SAFETY COUNCIL
National Institute of Building Sciences
1090 Vermont Avenue, NW, Suite 700
Washington, DC 20055
202-289-7800
www.@nibs.org

CALIFORNIA REDWOOD ASSOCIATION
405 Enfrente Drive, Suite 200
Novato, CA 94949
415-382-0662
www.calredwood.org

CANADA MORTGAGE AND HOUSING
CORPORATION
Housing Information Center
700 Montreal Road
Ottawa, ON, Canada K1A 0P7
613-748-2367
www.cmhc-schl.gc.ca

CANADIAN CONSTRUCTION MATERIALS CENTRE
Institute for Research in Construction
National Research Council
Montreal Road, Bldg. M-24
Ottawa, ON, Canada K1A 0R6
613-993-6189
www.nrc.ca/ccmc

CEDAR SHAKE AND SHINGLE BUREAU
515 116th Avenue, NE, Suite 275
Bellevue, WA 98004-5294
425-453-1323
www.cedarbureau.org

CELLULOSE INSULATION MANUFACTURERS
ASSOCIATION
136 South Keowee Street
Dayton, OH 45402
937-222-2462
www.cellulose.org

CONSTRUCTION SPECIFICATIONS INSTITUTE
601 Madison Street
Alexandria, VA 22314
703-684-0300
www.csinet.org

COPPER DEVELOPMENT ASSOCIATION
260 Madison Avenue
New York, NY 10016
800-232-3282
www.copper.org

COUNCIL OF AMERICAN BUILDING OFFICIALS
5203 Leesburg Pike, Suite 708
Falls Church, VA 22041
703-931-4533
www.cabo.org

ENERGY EFFICIENT BUILDING ASSOCIATION
Northcentral Technical College
1000 Campus Drive
Wausau, WI 54401-1899
715-675-3331
www.northcentral.tech.wi.us

EXPANDED POLYSTYRENE (EPS)
MOLDERS ASSOCIATION
1926 Waukegan Road, Suite 1
Glenview, IL 60025-1770
800-607-3772

FOREST PRODUCTS LABORATORY
U.S. Dept. of Agriculture
One Gifford Pinchot Drive
Madison, WI 53705-2398
608-231-9200
www.fpl.fs.fed.us/

HOME VENTILATING INSTITUTE
Div. of the Air Movement Control Association
30 West University Drive
Arlington Heights, IL 60004
847-394-0150
www.amca.org

INSTITUTE FOR BUSINESS AND
HOME SAFETY (IBHS)
73 Tremont Street
Boston, MA 02100-3910
617-292-2003
www.ibhs.com

INTERNATIONAL CONFERENCE OF BUILDING
OFFICIALS
5360 South Workman Mill Road
Whittier, CA 90601
800-336-1963
www.icbo.org

INTERNATIONAL FIRESTOP COUNCIL
25 North Broadway
Tarrytown, NY 10591
914-332-0040
www.firestop.org

INTERNATIONAL REMODELING
CONTRACTORS ASSOCIATION
17 South Main Street
East Granby, CT 06026
800-937-4722
www.remodelingassociation.com

LEAD INDUSTRIES ASSOCIATION
295 Madison Avenue, Suite 808
New York, NY 10017
212-578-4750
www.leadinfo.com

LIGHTNING PROTECTION INSTITUTE
3335 North Arlington Heights Road, Suite East
Arlington Heights, IL 60004
800-488-6864
www.lightning.org

METAL ROOFING SYSTEMS ASSOCIATION
1300 Sumner Avenue
Cleveland, OH 44115
216-241-7333
www.taol.com/mbma

NAHB REMODELERS COUNCIL
1201 15th Street, NW
Washington, DC 20005
202-822-0212

NAHB Research Center
400 Prince George's Boulevard
Upper Marlboro, MD 20772-8731
800-638-8556
www.nahbrc.org

NATIONAL ASSOCIATION OF THE
REMODELING INDUSTRY
3800 North Fairfax Drive, Suite 2
Arlington, VA 22203-1627
703-276-7600
www.ebtech.com

NATIONAL COIL COATERS ASSOCIATION
401 North Michigan Avenue
Chicago, IL 60611
312-321-6894
www.coilcoaters.org

NATIONAL FRAME BUILDERS ASSOCIATION
4840 West 15th Street, Suite 1000
Lawrence, KS 66049-3876
800-844-3781
www.knight.idir.net

NATIONAL INSTITUTE OF BUILDING SCIENCES
1090 Vermont Avenue, NW, Suite. 700
Washington, DC 20005
202-289-7800
www.nibs.org

NATIONAL PARTICLEBOARD ASSOCIATION
18928 Premiere Court
Gaithersburg, MD 20879-1569
301-670-0604
www.pbmdf.com

NATIONAL ROOFING CONTRACTORS
ASSOCIATION
10255 West Higgins Road, Suite 600
Rosemont, IL 60018-5607
847-299-9070
www.roofonline.org

NATIONAL TECHNICAL INFORMATION SERVICE
U.S. Department of Commerce
5285 Port Royal Road
Springfield, VA 22161
800-553-6847
www.ntis.gov

NATIONAL TILE ROOFING MANUFACTURERS
ASSOCIATION
P.O. Box 40337
Eugene, OR 97404-0049
541-689-0366

NATIONAL TRUST FOR HISTORIC PRESERVATION
1785 Massachusetts Avenue, N.W.
Washington, DC 20036
202-588-6000
www.nationaltrust.org

NORTH AMERICAN INSULATION
MANUFACTURERS ASSOCIATION
44 Canal Center Plaza, Suite 310
Alexandria, VA 22314
703-684-0084
www.naima.org

POLYISOCYANURATE
INSULATION
MANUFACTURERS ASSOCIATION (PIMA)
1001 Pennsylvania Avenue, N.W.
Fifth Floor
Washington, DC 20004
202-624-2709
www.pima.org

ROOF COATINGS MANUFACTURERS
ASSOCIATION
Center Park, Suite 404
4041 Powder Mill Road
Calverton, MD 20705
301-230-2501
www.roofcoatings.org

ROOF CONSULTANTS INSTITUTE
7424 Chapel Hill Road
Raleigh, NC 27607
800-828-1902
www.rci@rci-online.org

ROOFING INDUSTRY COMMITTEE OF
WIND ISSUES
13303 U.S. 19N
Clearwater, FL 34624
813-536-0456

ROOFING INDUSTRY EDUCATIONAL
INSTITUTE
14 Inverness Drive East, Building H, Suite 110
Englewood, CO 80112
303-790-7200
www.rieroof@aol.com

SEALANT, WATERPROOFING, AND
RESTORATION INSTITUTE
2841 Main
Kansas City, MO 64108
816-472-7974
www.swrionline.org

SHEET METAL AND AIR CONDITIONING
CONTRACTORS NATIONAL ASSOCIATION
(SMACNA)
P.O. Box 221230
Chantilly, VA 20153
800-336-0855
www.@smacna.org

SINGLE PLY ROOFING INSTITUTE
200 Reservoir Street, Suite 309A
Needham, MA 02494
781-444-0242
www.spri.org

SOUTHERN FOREST PRODUCTS ASSOCIATION
PO Box 641700
Kenner, LA 70064-1700
504-443-4464
www.sfpa.org

STEEL JOIST INSTITUTE
3127 10th Avenue, North
Myrtle Beach, SC 29577-6760
803-626-1995
www.steeljoist.org

STRUCTURAL INSULATED PANEL ASSOCIATION
1511 K Street, NW, Suite 600
Washington, DC 20005
202-347-7800
www.sipadc@aol.com

SWEDISH COUNCIL FOR
BUILDING RESEARCH
P.O. Box 12866, S-112-98
Stockholm, Sweden
46 8 617 73 00
www.bfr.se

TECHNICAL PRESERVATION SERVICE BUREAU

National Park Service
1849 C Street, Suite 200 NW
Washington, DC 20240
202-343-9578
www2.cr.nps.gov

TIMBER FRAME BUSINESS COUNCIL

c/o Jerry Rouleau
P.O. Box B1161
Hanover, NH 03755
603-643-5033

TRUSS PLATE INSTITUTE

583 D'Onofrio Drive, Suite 200
Madison, WI 53719
608-833-5900

WESTERN RED CEDAR LUMBER ASSOCIATION

1100-555 Bayard Street
Vancouver, BC, Canada V7X 1S7
604-684-0266
www.coti.org/WRCLA

WESTERN WOOD PRODUCTS ASSOCIATION

522 Southwest 5th Avenue
Portland, OR 97204-2122
503-224-3930
www.wwpa.org

THE REHAB GUIDE

VOLUME ONE: FOUNDATIONS

VOLUME TWO: EXTERIOR WALLS

VOLUME THREE: ROOFS

VOLUME FOUR: WINDOWS AND DOORS

VOLUME FIVE: PARTITIONS, CEILINGS, FLOORS, AND STAIRS

VOLUME SIX: KITCHENS & BATHS

VOLUME SEVEN: ELECTRICAL/ELECTRONICS

VOLUME EIGHT: HVAC/PLUMBING

VOLUME NINE: SITE WORK

U.S. Department of Housing and Urban Development
Washington, DC 20410-6000

Official Business
Penalty for Private Use, \$300

March 1999
HUD-DU100C000005956

