

VOL 5



THE **REHAB** GUIDE

PARTITIONS, CEILINGS, FLOORS & STAIRS



PATH (Partnership for Advancing Technology in Housing) is a new private/public effort to develop, demonstrate, and gain widespread market acceptance for the “Next Generation” of American housing. Through the use of new or innovative technologies the goal of PATH is to improve the quality, durability, environmental efficiency, and affordability of tomorrow’s homes.

Initiated at the request of the White House, PATH is managed and supported by the Department of Housing and Urban Development (HUD). In addition, all Federal Agencies that engage in housing research and technology development are PATH Partners, including the Departments of Energy and Commerce, as well as the Environmental Protection Agency (EPA) and the Federal Emergency Management Agency (FEMA). State and local governments and other participants from the public sector are also partners in PATH. Product manufacturers, home builders, insurance companies, and lenders represent private industry in the PATH partnership.

To learn more about PATH, please contact:

PATH
Suite B 133
451 7th Street SW
Washington, DC 20410
202-708-4250 (fax)
e-mail: pathnet@pathnet.org
website: www.pathnet.org

DISCLAIMER

The statements and conclusions contained in this report are those of Steven Winter Associates, Inc. and do not necessarily reflect the views of the Department of Housing and Urban Development. Steven Winter Associates, Inc. has made every effort to verify the accuracy and appropriateness of the report’s content. However, no guarantee of the accuracy or completeness of the information or acceptability for compliance with any industry standard or mandatory requirement of any code, law, or regulation is either offered or implied. The products listed in the report are included only as examples of some available products. No endorsement, recommendation, or evaluation of these products or their use is given or implied.

PARTITIONS, CEILINGS, FLOORS & STAIRS

VOLUME 5 OF THE REHAB GUIDE

TABLE OF CONTENTS

FOREWORD **3**

1. INTRODUCTION **4**

2. FLOOR/CEILING STRUCTURAL ASSEMBLIES **6**

3. SHEATHING/SUBFLOORING & UNDERLAYMENTS **21**

4. FINISH FLOORING **27**

5. FINISH WALL & CEILING MATERIALS **39**

6. STAIRS **51**

APPENDIX: PROFESSIONAL ASSOCIATIONS & RESEARCH CENTERS **61**

Prepared for:
U.S. Department of Housing
and Urban Development
Office of Policy Development
and Research

Prepared by:
Steven Winter Associates, Inc.
Building Systems Consultants
Norwalk, CT

Contract DUI00C000005956
November 1999

CREDITS

STEVEN WINTER ASSOCIATES, INC. STAFF MEMBERS
WHO WERE INSTRUMENTAL IN THE DEVELOPMENT AND
PRODUCTION OF THIS GUIDEBOOK INCLUDE:

Steven Winter
Principal-in-charge

Michael J. Crosbie, Ph.D., RA
Project manager and Editor-in-chief

Masaki Furukawa, Jeff Goldberg
Illustrators

Alexander Grinnell, Peter Stratton
Project team members

U.S. DEPARTMENT OF HOUSING AND URBAN DEVELOPMENT
OFFICE OF POLICY DEVELOPMENT AND RESEARCH, AFFORDABLE
HOUSING RESEARCH AND TECHNOLOGY DIVISION

David Engel
Director

Nelson Carbonell
Senior architect

GUIDEBOOK DESIGN

Andrew P. Kner
Art Director

Michele L. Trombley
Assistant Art Director

Elizabeth Rosen
Symbols

FOREWORD

President Clinton recognizes that research and technological innovation are crucial if America is to meet its affordable housing needs. In 1998, the President introduced a major new initiative: The Partnership for Advancing Technology in Housing (PATH). This initiative brings together leaders from the home building, product manufacturing, insurance, and financial industries, as well as representatives from federal agencies, to spur housing design and construction innovations.

Thanks to the development of new machinery and materials and the creation of new technologies and techniques, the construction industry has made great progress. But a breakthrough material, a labor-saving tool, or a cost-cutting technique is only valuable if it is widely adopted, which means the construction industry must first become aware of these new developments.

The Department of Housing and Urban Development can help. We have commissioned a set of guidebooks that will present state-of-the-art techniques, materials, and technologies for housing rehabilitation. This volume, *Partitions, Ceilings, Floors & Stairs*, is the fifth of nine guidebooks—known collectively as *The Rehab Guide*—that will appear over the next few years.

We are presenting these guidebooks because, like research and technological innovation, housing rehabilitation is an essential component of America's commitment to provide affordable housing. I am pleased to present this important publication in the hope that it will become a valuable resource that leads to affordable, high quality rehabilitation, and thus to better housing for all Americans.



Andrew Cuomo, Secretary
U.S. Department of Housing and Urban Development

INTRODUCTION

This series of guidebooks has been produced by the U.S. Department of Housing and Urban Development to keep the design and construction industry abreast of innovations and state-of-the-art practices in home rehabilitation. As is too often the case, innovative techniques, materials, technologies, and products are slow to make their way into accepted practice. It is evident that such innovations will not advance unless the industry is made aware of them and they are tested. *The Rehab Guide* is intended to accelerate this process by informing builders, architects, engineers, and other housing rehabilitation professionals about such innovations and state-of-the-art practices.

The Rehab Guide was also prompted by the lack of a comprehensive publication to make the design and construction industry aware of innovative and cost-saving developments in housing rehabilitation. Professional trade magazines, conferences, and trade shows offer some dissemination of this information, but they are rarely focused exclusively on housing rehabilitation, as this series is, nor are they comprehensive.

FOCUS OF THE REHAB GUIDE

The focus of this series is on housing rehabilitation, which is different than home improvement. Rehabilitate means “to restore to good condition,” not necessarily to improve to a state that is significantly different than the original. This is a fine line, but it distinguishes this series from “home improvement” books written for the amateur. *The Rehab Guide* focuses on building technology, materials, components, and techniques rather than “projects” such as adding a new room, converting a garage into a den, or finishing an attic. Nor is *The Rehab Guide* intended to be a “diagnostic” tool; a number of such books are already available to the industry.

The content for this guidebook, *Partitions, Ceilings, Floors, & Stairs*, has been gathered from professionals in the housing rehabilitation field; manufacturers and suppliers of innovative technologies, materials, components, tools, and equipment; trade shows, conferences, reports, and publications considering such issues; trade organizations; and building research centers.

A NOTE ON SOURCES

A variety of excellent resources exists for information on partitions, ceilings, floors, and stairs. *Floors and Stairways*, published by Time-Life Books, is a comprehensive book on floors and stairs. *Carpet: Installation and Maintenance for Maximum Performance*, published by the Carpet and Rug Institute, is an excellent source for information on carpet rehabilitation. *House Painting Inside and Out*, published by The Taunton Press, and *Respectful Rehabilitation: Walls and Moldings*, published by the Preservation Press, are sources for information on paints, wallcoverings, and moldings and trim. Monthly publications of interest include the *Energy Design Update*, *Environmental Building News*, *Journal of Light Construction*, *Home Energy*, *Old House Journal*, *This Old House*, and *Traditional Builder*. Helpful information is also accessible via the Internet. Most equipment manufacturers and monthly magazines have Web sites where specific product information and past articles can be retrieved. The Department of Energy provides a wealth of information on energy conserving techniques and technologies at www.eren.doe.gov/consumerinfo/.

LEAD PAINT HAZARD

The hazard of lead paint in houses constructed before the 1980s is not discussed in the *The Rehab Guide* because there is extensive material available from HUD, the Environmental Protection Agency (EPA), and other sources. However, if you are a non-profit or rehab contractor rehabilitating pre-1978 housing for sale or rent, or if you are a homeowner rehabilitating a home for your own use, you are strongly urged to have the home tested for lead paint. This is especially critical if the home will be occupied by young children. Very small

amounts of lead in paint or dust can poison children if swallowed or inhaled, causing damage to the brain and other organs, resulting in health problems and reduced intelligence. If lead paint is found, it is critical that all rehabilitation be done very carefully to reduce the possibility of lead poisoning to you or your workers. Proper work practices will minimize the risk of spreading lead contamination and increasing occupant exposure.

One of the best and most recent sources on this subject is the HUD publication, "Lead Paint Safety: a Field Guide for Painting, Home Maintenance, and Renovation Work." Another good publication is the EPA brochure, "Reducing Lead Hazards When Remodeling Your Home." Both can be obtained by calling the National Lead Information Center at 800-424-LEAD or by downloading from the web site of the HUD Office of Lead Hazard Control, www.hud.gov/lea. A very comprehensive source is the HUD publication, "Guidelines for the Evaluation and Control of Lead-Based Paint Hazards in Housing," which gives guidance on controlling lead hazards, lead paint and rehab work, risk assessment, monitoring, inspections, resident and work site preparation, worker protection, and routine building maintenance. This publication is available through HUD-User; you can also download a copy of this document from the HUD web site at: www.hud.gov:80/lea/learules.html.

HUD has new regulations on lead-based paint hazards in federally owned housing and housing receiving federal assistance. If you will be using HUD funds for rehabilitation through grants, insurance, or other types of assistance, then there are protective procedures that must be followed. The Occupational Safety and Health Administration web site at www.osha.gov has information on worker protection requirements. In addition, many states and localities have their own rules regarding lead-based paint, which should be followed when undertaking rehabilitation.

HOW THE GUIDE IS ORGANIZED

Nine volumes make up *The Rehab Guide* in its entirety, and they are listed on the back cover of this volume. Each one is devoted to distinct elements of the house, and within each volume is a range of issues that are common to that element of home rehabilitation work. This volume covers topics from repair of wall and ceilings surfaces, rehabilitation of floor finishes, and fixing trim, to reconstructing stairs. Each volume addresses a wide range of techniques, materials, and tools, and recommendations based on regional differences around the country. Throughout *The Rehab Guide*, special attention is given to issues related to energy efficiency, accessible design, and sustainability.

The Rehab Guide is written and presented in a format intended for easy use. The spiral bound volumes open flat so that they can be easily photocopied, and they can be assembled and stored in a single three-ring binder. Within each volume, drawings, photos, and other graphic materials supplement written descriptions of a broad range of items: state-of-the-art and innovative building technology, products, materials, components, construction and management techniques, tools, equipment, software—virtually any and all items that make housing rehabilitation more efficient in terms of cost and time. While the content focuses on present technologies and techniques that are currently part of the house-building industry, *The Rehab Guide* also includes information on materials, products, and procedures from other construction sectors (such as commercial, industrial, institutional) that are relevant to housing rehabilitation.

The information is organized in different sections according to rehab subjects, and under headings that make this book easy to understand. "Essential Knowledge" gives the reader a basic overview of the important issues related to the section heading. Next, "Techniques, Materials, Tools" presents state-of-the-art and innovative approaches to accomplishing the work. Each entry is explained in detail, including its advantages and disadvantages. This makes it easy for readers to compare approaches and choose the one that is most applicable to their particular project. By design, the "Techniques, Materials, Tools" section is an overview, not a detailed description of implementation. "Further Reading" lists the valuable resources relevant to the subject that readers can go to for more detailed information. Finally, "Product Information" provides names and addresses of manufacturers of products, materials, systems, and components mentioned in the text so that more information can be obtained. By virtue of their being listed here, such products are not necessarily being recommended; their existence and availability are being brought to the reader's attention. New products should be carefully evaluated in the field as to their performance. The product lists are not necessarily comprehensive, and we encourage readers to bring new materials and products to our attention to be included in later editions of *The Rehab Guide*.

2

FLOOR/CEILING STRUCTURAL ASSEMBLIES

2.1

OVERVIEW

If a building's foundations, exterior walls, and roofs have been well maintained, and the building has been free of plumbing leaks, general abuse, overloading from heavy objects, and damage from vermin and insects, then chances are that its floor/ceiling structural assemblies will be in reasonably good shape. Exceptions to this include problems caused by deficient design, engineering, or construction, or inappropriate material selection or detailing. If, however, the building's roofs, exterior walls, and foundations have not been adequately maintained, the floor/ceiling structural assemblies (and the partitions and stairs that attach to them) will likely have suffered from the settlement, and insect and moisture-related deterioration that affects the rest of the structure. This section addresses common structural deficiencies of floor/ceiling assemblies. Moisture, insect, and fire-related issues are covered more extensively in *Volume 2: Exterior Walls* and *Volume 3: Roofs*. Additionally, because a structural rehab may involve removing and reframing deteriorated structure, recent innovations in joists, beams, and headers will be reviewed.

2.2

COMMON STRUCTURAL PROBLEMS

ESSENTIAL KNOWLEDGE

Most problems with floor/ceiling structural assemblies are related to excessive sagging/deflection and can be attributed to a number of deficiencies, including beam strength that has been reduced by extensive notching at joist-framing connections and joists that are excessively cut at ends (Fig. 1) where they frame into girders (typical in pre-1900s houses); joists that have been excessively cut, notched, or bored (Fig. 2) to accommodate material changes, pipes, wiring, or ducts (code agencies and manufacturers of engineered wood beams and joists stipulate limits to such modification); insufficiently sized supporting beams; inadequately sized or spaced floor joists and fasteners; excessive spacing of posts supporting the beams; rotting of posts at bearing points; and insufficient or settled footings under the posts. Problems with partitions are usually related to insufficient floor support or shrinkage of the studs, which are dealt with below.

Most current codes limit deflection for floors to $L/360$ (length of joist/360) which is derived from long-standing standards based on the deflection at which a plaster ceiling of the space below the floor would crack. While this is generally considered adequate to control deflection, some architects, engineers, and designers believe that stiffer floors are necessary for a user's sense of well-being, and design to higher deflection limits (such as $L/480$) or increase the floor load requirements from 40 psf on the

non-bedroom floors to as much as 100 psf in the more public spaces such as kitchens, entries, family rooms, and living rooms. Another approach is to limit deflection to a maximum, for example 1/2". Many older houses built before 1920 have floor joists sized considerably below current requirements. It is not uncommon to find 3x6 and 3x8 joists in pre-1900s housing that, in some cases, have been notched where they frame into girders by as much as one-half their depth. These members may well be split, especially if they have been affected by rot or insect damage. Because of the large safety factor used in the design of newer floor systems (up to factor of four), floors will rarely fail structurally, but they may have excessive bounce and feel unsafe.

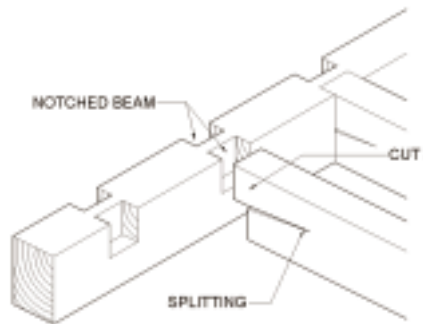

FIGURE 1

EXCESSIVE NOTCHING OR CUTTING OF BEAMS AND JOISTS

Joist Size	Maximum Hole	Maximum Notch Depth	Maximum End Notch
2x4	None	None	None
2x6	1-1/2	7/8	1-3/8
2x8	2-3/8	1-5/4	1-7/8
2x10	3	1-1/2	2-3/8
2x12	3-3/4	1-7/8	2-7/8

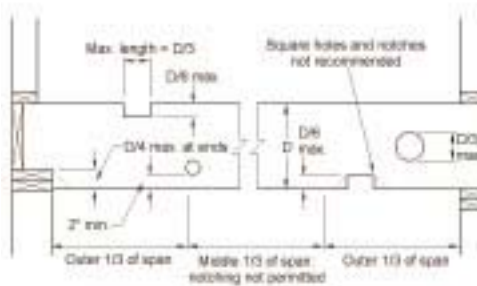

FIGURE 2

GUIDE FOR CUTTING, NOTCHING, AND BORING JOISTS

TECHNIQUES, MATERIALS, TOOLS

1. REINFORCE EXISTING MAIN BEAM BY ADDING SUPPORT.

A house's main beam that is over-stressed, has deflected excessively over time, or has been affected by termites can be reinforced by adding a steel or wood column or a masonry pier to reduce the beam span (Fig. 3). It may also be possible to jack up the sagging beam to reduce or eliminate a slope in the finish floor above, although long-term settling is often difficult if not impossible to eliminate.

ADVANTAGES: A relatively simple and effective way to stabilize a building's major structural element.
DISADVANTAGES: Difficult to accomplish in other than basement or crawlspace areas, as columns may have to be placed in inconvenient places and will require some removal and restoration of existing finishes. Beams over crawlspaces may be difficult to access.

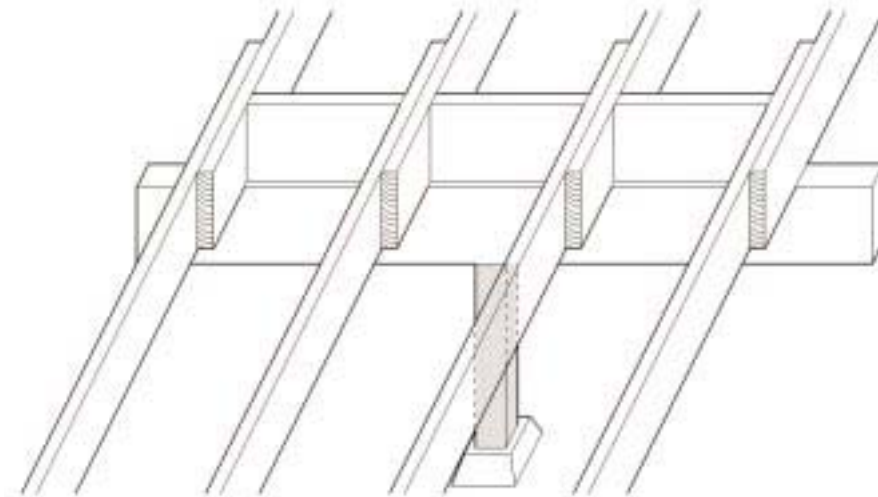

FIGURE 3

NEW COLUMN SUPPORT

2. REINFORCE THE EXISTING BEAMS OR JOISTS.

Existing beams or joists can be reinforced by adding steel or wood reinforcement (sistering) along the existing members to develop additional load-carrying capacity (Fig. 4). The length and bearing of the new reinforcing beams or joists will depend on the existing conditions and should be reviewed with a structural engineer.

ADVANTAGES: Can eliminate the use of a new column support; does not affect the space below the beam.
DISADVANTAGES: May be difficult to insert new support alongside the existing beam if access is a problem (such as in crawlspaces) or if joists frame directly into beam (Fig. 5), in which case the existing floor joists would have to be temporarily supported, a new beam installed, and the joists hung from the new beam with joist hangers (Fig. 6).

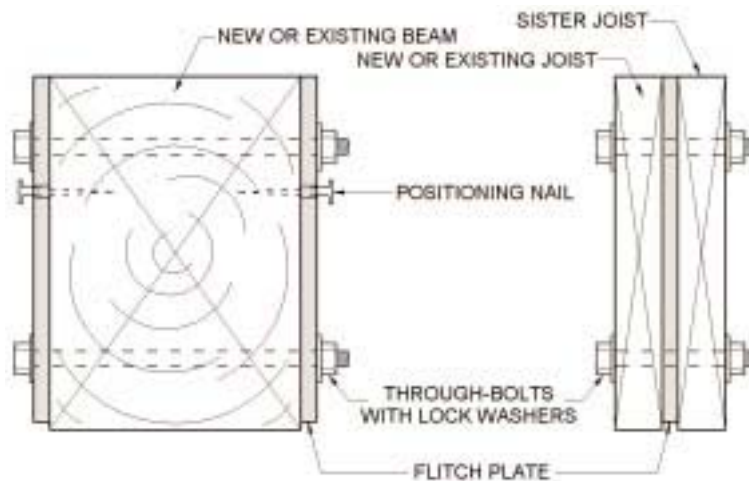

FIGURE 4

STEEL FILCH PLATE REINFORCEMENT

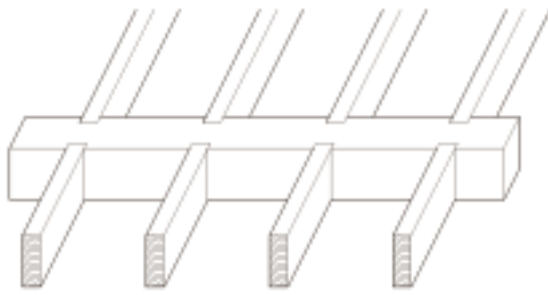

FIGURE 5

JOISTS FRAMING INTO NOTCH BEAM

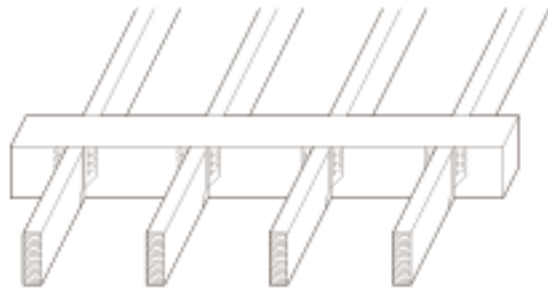

FIGURE 6

NEW BEAM WITH JOISTS ATTACHED WITH JOIST HANGERS

3. TRANSFER LOAD TO EXISTING JOISTS

If a floor joist has been severely cut to accommodate a large pipe or wiring, it may be impossible to splice on a reinforcement member. In this instance, it may be preferable to transfer the load from that joist to adjacent joists using header joists that are end-nailed across the cut end of the interrupted joist to the adjacent trimmer joist. If the header has a span of 4' or less a single header may be satisfactory (Fig. 7). For wider openings (up to 10') headers can be doubled up (Fig. 8). Consult with a structural engineer or architect to verify.

ADVANTAGES: Can reinforce floors when other alternatives are not practicable.

DISADVANTAGES: Not possible where access is a problem.

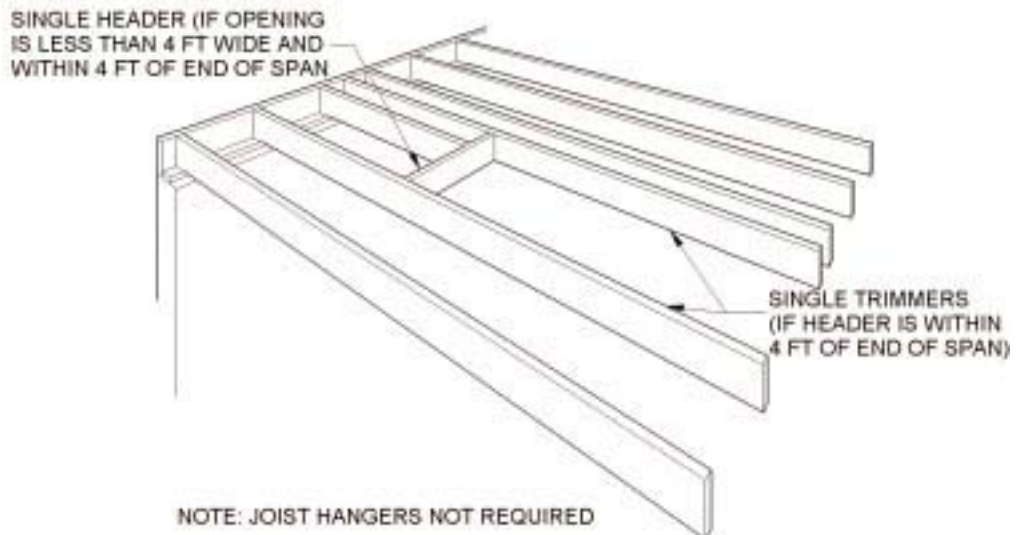

FIGURE 7

FLOOR OPENING FRAMED WITH SINGLE HEADER AND SINGLE TRIMMER JOISTS

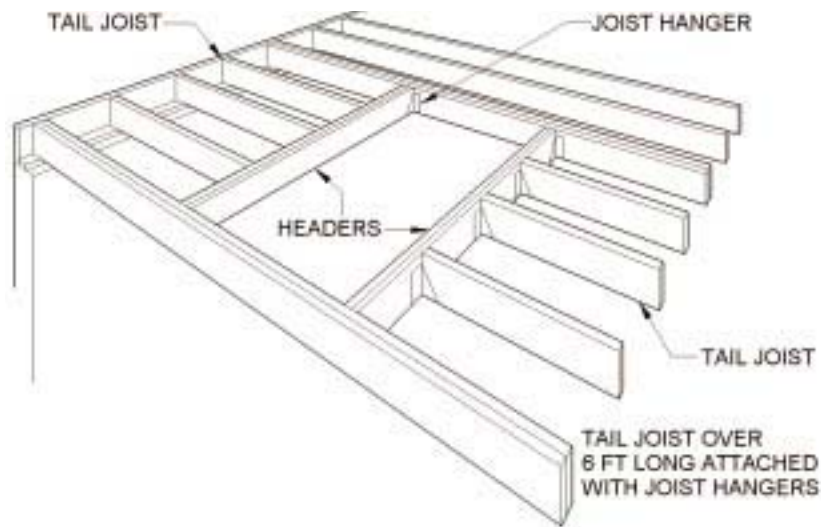

FIGURE 8A

FLOOR OPENING FRAMED WITH DOUBLE HEADER AND DOUBLE TRIMMER JOISTS (JOIST HANGERS USED FOR LONGER TAIL JOIST)

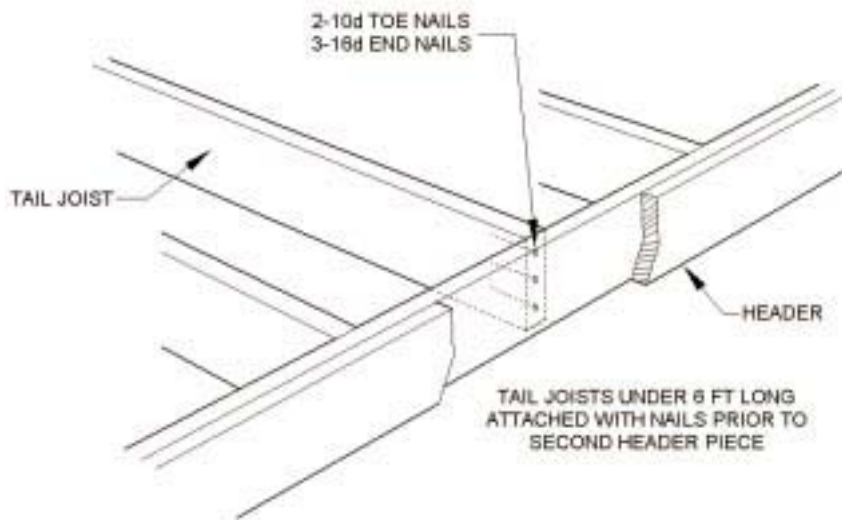

FIGURE 8B

FLOOR OPENING FRAMED WITH DOUBLE HEADER AND DOUBLE TRIMMER JOISTS (NAILING TAIL JOISTS UNDER 6' LONG)

FURTHER READING

Rehabilitation of Wood-Framed Houses, U.S. Department of Agriculture, Forest Service, Agriculture Handbook No. 704, Feb. 1998.

Renovating Old Homes, George Nash, Newtown, CT: Taunton Press, 1996.

Renovation: A Complete Guide (2nd Edition), Michael W. Litchfield, New York: Dutton, 1992.

"The Structure of Wood Frame Homes," Gordon Bock, *Old-House Journal*, March/April 1992.

"Steelwork in Wood Frames," Eric Bauer, *Journal of Light Construction*, April 1992.

"Structural Repair Under an Old Floor," Peter Borgemeister, *Old House Journal*, March/April 1992.

“Taking the Bounce Out of Floors and Beams,” Harris Hyman, in *Advanced Framing Techniques, Troubleshooting and Structural Design*, Journal of Light Construction, 1992.

The Old House Journal Guide to Restoration, edited by Patricia Poore, New York: Dutton, 1992.

“Wall and Floor Framing,” in *Troubleshooting Guide to Residential Construction*, David Utterbach, Journal of Light Construction, 1997.

PRODUCT INFORMATION

STRUCTURAL CONNECTORS

Wood Construction Connectors, Simpson Strong-Tie Co., Inc.; 4637 Chabot Drive, Suite 200, Pleasanton, CA 94588; 800-999-5099; www.strongtie.com.

WOOD RESTORATION SYSTEMS

Abatron, Inc., 5501 95th Avenue, Dept. OH, Kenosha, WI 53144; 800-445-1754; www.abatron.com.

2.3

ALTERNATIVES TO SOLID LUMBER FOR FLOOR FRAMING

ESSENTIAL KNOWLEDGE

A variety of structural materials is available as an alternative to solid wood framing when existing framing needs to be reinforced or when sections of existing houses need to be rebuilt. Light steel sections and steel fitch plates have a long history of use in wood-frame construction for carrying heavy loads over long spans. Wood floor trusses connected with metal plates and webs have been in use since the 1970s. Glued laminated timbers (glulams), initially developed in 1890, have been used since the 1950s for both exposed beams in post-and-beam structures and concealed as headers and girders in long spans such as garage door openings. There is little possibility of repairing existing glulams if they are delaminated or over-stressed, in which cases they should be replaced with new material or additional supports, respectively. Today there is a wide range of such products as engineered wood I-joists and structural composite lumber (SCL) have been developed and are in use. The following documents the repair of traditional products as well as the physical characteristics of some of the newer products.

TECHNIQUES, MATERIALS, TOOLS

1. REPAIR EXISTING TRUSSES.

The critical components of typical floor trusses are the metal connector plates. Damage to the plates, when it occurs, usually happens during handling, especially when trusses are lifted vertically off the ground or raised from a horizontal to vertical position. Serious racking can cause the truss chords to break or the metal plates to disengage. Another cause of plate failure is deterioration from high salt and moisture-laden environments. Assuming it was properly designed, if an existing truss plate shows white rust on the zinc coating or minor red rust around the edges, and the metal plate is correctly engaged, the truss is probably performing satisfactorily. If the plate exhibits significant blistering and scaling, the probable causes (typically excessive moisture) should be addressed and corrected before remedial work is undertaken. Corrective work can include the removal of scale from the plate and recoating with an appropriate rust-

inhibiting paint, and the use of wood gusset plates or additional hand-driven metal plate connectors.

ADVANTAGES: May allow the continued use of isolated trusses without the cost of replacement.

DISADVANTAGES: Not usually possible if deterioration or damage is severe or widespread. Requires review by an engineer.

2. REPLACE EXISTING JOISTS WITH NEW METAL PLATE CONNECTED TRUSSES.

Wood floor trusses are available in a wide variety of sizes and styles both as standard commodity items and in project-specific configurations. The majority are made with 2x3, 2x4, and 2x6 lumber held together by metal plate connectors (Fig. 9). The punched connector plate acts as an array of short nails attached to a common head. Connectors are sized to ensure that the trusses can take their in-plane design load as well as out-of-plane loadings that occur during assembly, handling, transportation, storage, and erection.

ADVANTAGES: Greater span capability than solid wood joists. Often eliminates need for center beam and columns. Open web permits running plumbing, duct work, and wiring through trusses. Economical, very efficient use of small sections of dimensional lumber. Lightweight and easily handled and worked in normal lengths without heavy equipment. Available throughout the country.

DISADVANTAGES: Requires more careful handling than comparable solid timbers and I-joists. Longer lengths (over 30') require lifting equipment and spreader bars. Combustible, performs less well in fire than thicker, solid framing. Less dimensionally stable than other framing types.

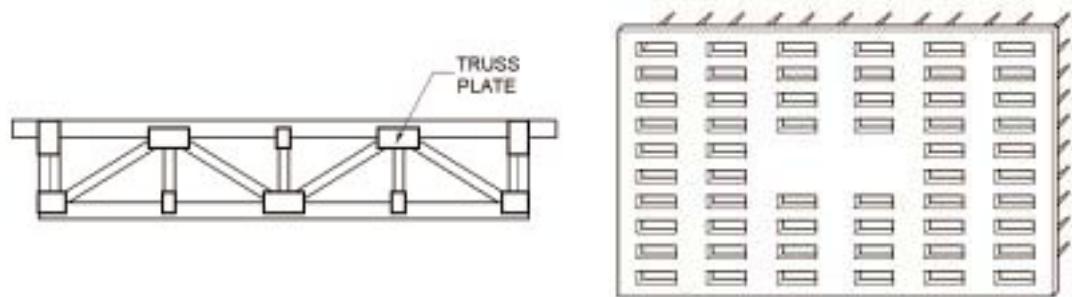

FIGURE 9

DIAGRAMMATIC FLOOR TRUSS

METAL TRUSS PLATE

3. REPLACE EXISTING STRUCTURE WITH GLULAMS.

Glulams (Fig. 10) are typically used to replace deficient beams or headers that carry heavy loads such as ridge beams and garage door headers. They are made up of wood laminations 2 1/2" to 10 3/4" wide that are bonded together to form beams of varying depths. Beams are manufactured with the highest grade laminations on the top and bottom where the greatest compression and tension occurs. There are three appearance grades: Premium, Architectural, and Industrial, the latter being recommended for concealed locations or where appearance is not a factor. Appearance does not affect structural characteristics.

ADVANTAGES: Greater strength and stiffness than comparable dimensional lumber. More efficient than solid lumber for large spans and loads. Available in wider sections than laminated veneer lumber which has to be bolted together to carry equivalent loads. The only engineered wood product that can be easily cambered to reduce the visual effect of deflections or can be produced in curved shapes and arches for long spans. Has striking appearance and can be left exposed.

DISADVANTAGES: More costly than structural composite lumber. Cannot be nailed; requires bolts and metal hangers.

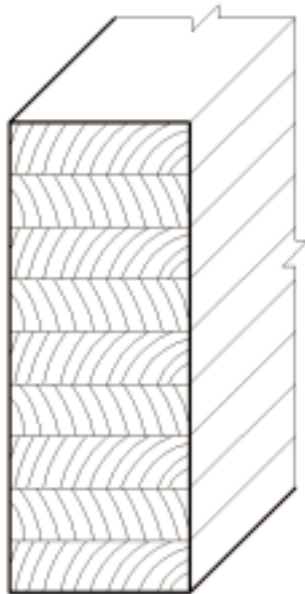

FIGURE 10

GLULAM

4. REPLACE EXISTING STRUCTURE WITH WOOD I-JOISTS

First marketed by Trus Joist Corporation in the late 1960's, wood I-joists (Fig. 11) are currently produced by over a dozen companies in North America. I-joists are used predominantly as an alternative to sawn lumber floor joists or parallel-chord trusses in repetitive light frame construction, although they are also used for beams and headers. The I-joist is a very efficient structural shape simulating that of a steel I-beam. I-joists typically have single webs, but at least one manufacturer, Superior Wood Products, makes a rigid-foam-insulated, double-webbed member for use as a header. Most I-joists are available with 1 1/2" round "knock outs" spaced 12" oc to accommodate pipes and wiring.

ADVANTAGES: Can be used as a floor joist, header, or rafter/roof joist. Lightweight, easy to handle and install, with longer, unsupported spans and higher load-bearing capacity than solid sawn lumber of equivalent size. Available in a wide variety of sizes and lengths. Dimensionally stable, resists shrinking, warping, splitting, or twisting that can lead to squeaky floors. Environmentally sound, uses less wood and lower quality trees than conventional lumber.

DISADVANTAGES: In longer lengths, I-joists require more careful handling than equivalent solid lumber members. Lack of single, industry-wide performance standard makes comparison of products challenging.

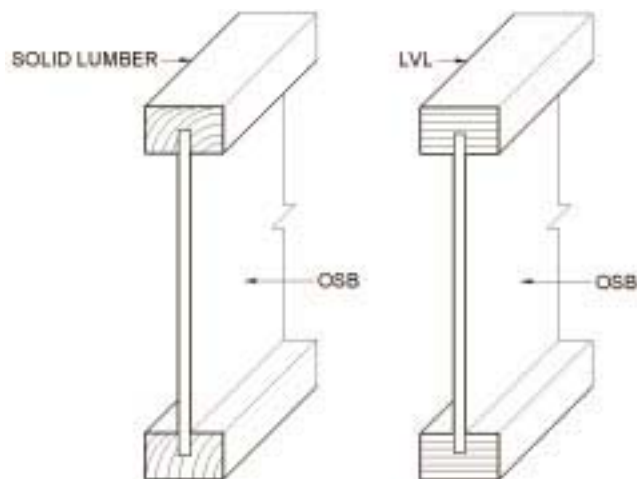

FIGURE 11

WOOD "I" JOIST

5. REPLACE EXISTING STRUCTURE WITH LAMINATED VENEER LUMBER.

Laminated veneer lumber (LVL) was initially developed by Weyerhaeuser Corporation in the early 1960s, but was not produced commercially until the Trus Joist Corporation developed and began to produce Microllam[®] in 1968. LVL consists of layers of kiln-dried wood veneer (typically douglas-fir and southern pine) laminated together with a structural adhesive with their veneer grains aligned with the length of the member (Fig. 12). They are typically used for girders and headers over long spans such as garage door openings, and as flange material for I-joists.

ADVANTAGES: Combines best qualities of natural wood with the strength and consistent performance of engineered wood products; easy to work with, can be cut and nailed in field. Dimensionally stable; resists shrinkage, warping, splitting, and checking. Available in wide variety of sizes from a number of manufacturers.

DISADVANTAGES: Relatively costly.



FIGURE 12

LAMINATED VENEER LUMBER (LVL)

6. REPLACE EXISTING STRUCTURE WITH PARALLEL STRAND LUMBER.

Parallel strand lumber (PSL) was developed by MacMillan-Bloedel and introduced in 1984 under the trade name Parallam[®] PSL. It is currently produced exclusively by Trus Joist MacMillan. Parallam[®] PSL (Fig. 13) is made of strands of clear sapwood from outer portions of Douglas-fir, western hemlock, southern pine and yellow-poplar, that are not usable in the making of LVL. The strands are combined with water-proof structural adhesives; formed into a mat under heat and pressure; formed into billets; and ripped into smaller members.

ADVANTAGES: Has the highest stiffness and strength of all the composite lumber products. Used where both strength and appearance are important. Makes even greater use of wood fibers than LVL. Can be preservative and fire-retardant treated. Available in a variety of sizes and lengths. Thick members eliminate the need for multiple bolted or nailed-together LVLS or solid lumber members.

DISADVANTAGES: Heavier than equivalent size sawn or glued-laminated lumber. More abrasive to saws and drills than LVL because of higher adhesive density. Requires connections be made with metal plates and bolts rather than nails. Relatively costly; available only from a single manufacturer.

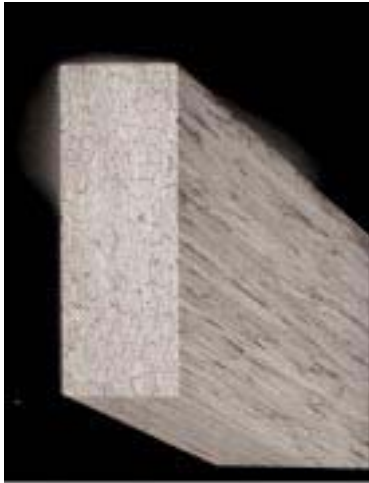

FIGURE 13

PARALLEL STRAND LUMBER (PSL)

7. REPLACE EXISTING STRUCTURE WITH LAMINATED STRAND LUMBER.

Laminated strand lumber (LSL) was developed by MacMillan-Bloedel and has been produced since 1991 by Trus Joist MacMillan under the trade name TimberStrand[®] LSL and is a recent structural composite lumber product (Fig. 14). LSL strands are longer (approximately 12") than those used in PSL. LSL is used primarily for beams and headers, although it is increasingly used for studs.

ADVANTAGES: Retains the advantages of both LVL and PSL products, but has the additional advantage of being able to be made from small, crooked logs of many species such as aspen and yellow-poplar that are fast growing and underutilized (used for making OSB).

DISADVANTAGES: Not as dimensionally stable as LVL or PSL products. Requires connection be made with metal plates and bolts, rather than nails. Available only from a single manufacturer.



FIGURE 14

LAMINATED STRAND LUMBER (LSL)

FURTHER READING

Glued Laminated Timber Appearance Classifications for Construction Applications, APA/EWS Y110, April 1998.

Glulams in Residential Construction, APA/Engineered Wood Systems, December 1995.

Handling, Installing and Bracing MPC'ed Wood Trusses, HIB-91, Truss Plate Institute.

"On Site with Parallam," Patricia Hamilton, *Journal of Light Construction*, December 1995.

Product and Application Guide, APA/Engineered Wood Systems, June 1995.

"Structural Composite Lumber," Sherman Nelson, P.E., in *Engineered Wood Products - A Guide for Specifiers, Designers and Users*, Madison, WI: PFS Research Foundation, pp. 147-172.

What We Learned by Framing the American Dream, Wood Truss Council of America, 1996.

"Wood Framing," in *Trouble Shooting Guide to Residential Construction*, Journal of Light Construction, 1997, pp. 34-38.

PRODUCT INFORMATION

Membership and Product Directory, 1996, APA Engineered Wood Association, P.O. Box 11700, Tacoma, WA 98411-0700; 253-565-6600; www.apawood.org.

BCI[®] Joists, Versa-Lam[®] and Versa-Rim[®], Boise Cascade Corporation, P.O. Box 50, Boise, Idaho 83728-0001; 208-384-6161; www.bc.com.

StrucJoist[®], StrucLam[®], Glulam and E-Z Rim[®], Willamette Industries, Inc., 800-887-0748.

Parallam[®], Microllam[®], TimberStrand[®], TJI[®] joist; Trus Joist MacMillan, P.O. Box 60, Boise, ID 83707; 800-628-3997; www.tjm.com.

Steel Floors, LLC, 7935 E. Prentice Ave., Suite 103, Greenwood Village, CO 80111; 303-804-5771.

2.4

MOISTURE DETERIORATION

ESSENTIAL KNOWLEDGE

Water absorbed by wood framing can raise its moisture content, reduce its compressive and tensile strength, ultimately cause rot and decay, and attract termites and other pests (see *Volume 2: Exterior Walls*). Interior partitions and floors are typically not affected by moisture if the building envelope is watertight and the basement dry. Exceptions to this are problems caused by the long-term presence of moisture from sources such as faulty plumbing and interior roof drains or the generation of excess humidity as a result of cooking, clothes washing, or excessive humidification. The first floor is most typically affected by moisture because it is usually over a crawl space or basement. Fortunately, in many cases, the floor structure is exposed. The condition of the existing joist can be sampled with a sharp object such as a screwdriver or pocket knife. Sound wood will split into fibrous splinters, while decayed wood will separate into small chunks of a dark brown, black, or grey color. Decay can also be revealed by rapping on the surface of the wood member; a dull, hollow sound frequently indicates decay below the surface. Decayed lumber can be reinforced with additional structure, stabilized with structural epoxy conservation techniques, or by a combination of both.

TECHNIQUES, MATERIALS, TOOLS

1. REPAIR EXISTING JOISTS WITH EPOXY CONSOLIDANTS.

Portions of existing deteriorated joists can be repaired and reconstituted by the use of epoxy consolidants. While this technique is more typical with supported members such as sills, it can be useful when combined with additional adjacent reinforcing members (Fig. 15).

ADVANTAGES: An effective fix for historic structures by maintaining the original structural profile.

DISADVANTAGES: Expensive, not usually cost-effective when rot is widespread or in most non-historic situations, where the use of additional reinforcing structure is more practical.

2. REPAIR/REPLACE EXISTING JOISTS WITH SUPPORTING STRUCTURE.

The most typical repair of deteriorated structure is to add vertical supports or beams to shorten the spans; to add scabbed (spliced) members at deteriorated ends (Fig. 15), or to add new wood or steel reinforcement alongside the existing members (see Section 2.2 above). Individual repairs should be supervised by a structural engineer based on site-specific conditions.

ADVANTAGES: Structural repairs are practical if the deteriorated portions of beams or joists is limited and typically near the bearing ends or where space limitations restrict the introduction and use of longer structural members.

DISADVANTAGES: Reinforcing existing members is time-consuming, and may not be as cost-effective as installing new adjacent members where access is feasible.

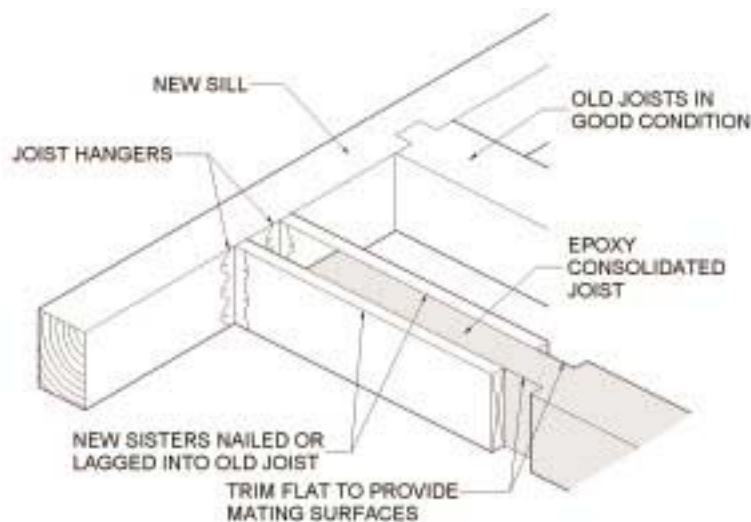

FIGURE 15

EPOXY CONSOLIDATED SISTERED JOIST

FURTHER READING

Renovating Old Houses, George Nash, Newtown, CT: Taunton Press, 1996.

PRODUCT INFORMATION

Abatron, Inc. Wood Restoration Systems, 5501-95th Avenue, Department HP, Kenosha, WI 53144; 800-445-1754; www.abatron.com.

Preservation Resource Group, P.O. Box 1768, Rockville, MD 20849-1768; 301-309-2222; www.prginc.com.

Wood Care Systems, 751 Kirkland Avenue, Kirkland, WA 98033; 800-827-3480; www.woodcaresystems.com.

ESSENTIAL KNOWLEDGE

Damage from fire can range from the total loss of a building and its contents to inconvenience from smoke odors. Unless the damage is limited, the restoration process can be complicated, involving structural, electrical, HVAC, plumbing systems, as well as building finishes. In addition, significant health and comfort issues arise from the residual smoke, combustion gases, moisture from fire department hoses, and the existence of products containing asbestos. The selection of a restoration contractor who is experienced and knowledgeable in current techniques is critical. At least one national association, the Association of Specialists in Cleaning and Restoration (ASCR), manages training and certification programs and publishes a restoration guideline.

TECHNIQUES, MATERIALS, TOOLS**1. RESTORE FIRE-DAMAGED STRUCTURAL MEMBERS.**

The first step in restoring structural members is to assess the damage to the building structure, systems, and finishes. In 2x4 construction, significantly charred members are generally removed in their entirety. Heavy timber construction can remain (according to the American Society of Civil Engineers), once the char is removed and if the remaining section is still structurally adequate (after a reduction-in-size-factor of 1/4" on all sides). Char is removed by scraping and abrasive blasting. It should generally be removed because it holds odors, although encapsulating coatings inhibit their transmittal. Sheathing materials (especially charred or unsound fire-retardant-treated material) should also be removed. New construction that replaces the damaged construction should meet codes for new construction. Smoke-damaged materials should be cleaned and deodorized as necessary. The use of ozone generators, sometimes used to remove odors and contaminants, is controversial and considered by a number of specialists to be ineffective and potentially dangerous (see Further Reading). Water-damaged materials, such as insulation, should be replaced when the damage is irreversible.

ADVANTAGES: Can allow a large portion of the building to be salvaged.

DISADVANTAGES: Odors from fire damage may linger; can be costly repair.

2. SALVAGE FIRE-DAMAGED GLULAMS.

Glulams perform relatively well in fires (wood chars at the rate of 1/40" per minute) and may be able to be salvaged and reused once the char is removed, if the remaining section is structurally adequate. This determination should be made by a structural engineer, based on job-site conditions.

ADVANTAGES: Fire damaged glulams can be reused in some instances.

DISADVANTAGES: May retain smoke odors.

FURTHER READING

Evaluation, Maintenance, and Upgrading of Wood Structure, American Society of Civil Engineers, 1982.

NIDR - Guidelines for Fire and Smoke Damage Repair, National Institute Disaster Restoration (a division of the Association of Specialists in Cleaning and Restoration); 1997; (301) 684-4411; www.ascr.org.

Odor Removal Manual, Volume I, Clifford B. Zlotnik, Unsmoke Systems, Inc., 1997.

"Research Sheds New, Unfavorable Light on Ozone Generators," *IEQ Strategies*, P.O. Box 129, Center Strafford, NH 03815-0129; 603-664-6942; www.cutter.com/energy/.

Restoration Technology, Volume I, Clifford B. Zlotnik, Unsmoke Systems, Inc, 1996.

PRODUCT INFORMATION

Unsmoke Systems, Inc., 1135 Braddock Avenue, Braddock, PA 15104; 800-332-6037.

ESSENTIAL KNOWLEDGE

Sound travels through the structure itself in the form of vibrations caused by direct mechanical contact with a source such as a washing machine or air-distribution motors, footsteps, a dropped object, and other impacts. The control of structureborne sound is generally treated as a floor problem, since this is where the majority of complaints originate. An excellent resource on residential acoustical theory and practice (and the source of much of the data in the following section) is *Noise Control Manual for Residential Building* by David A. Harris (see Further Reading).

TECHNIQUES, MATERIALS, TOOLS**REDUCE AIRBORNE AND IMPACT SOUNDS IN FLOOR/CEILING SYSTEMS**

Sound borne through floor/ceiling systems can be treated in much the same way as in walls, by increasing the mass, providing resilient connections, and adding sound absorbing material to the floor surface or the floor/ceiling cavity. Fortunately, most floor systems have more mass and thickness than walls, making it easier to achieve sound-deadening properties. Impact sounds, however, are more difficult to control because the stiff, light assembly acts as a drum under such impacts as footsteps and falling or moving objects. Reducing impact is best accomplished by treating the floor with cushioning material, such as carpets and underlayments. Unfortunately, there are some areas where carpet is not practical, such as in kitchens and baths, or not desired. In these cases, it is possible to use such materials as sound deadening board, cork, sound control matting, a foam gasket between the floor joist and sheathing (Fig. 16) or sound isolating pads or mats under the finish flooring to provide a “floating floor.” Other, more complicated and costly techniques include resistant ceiling channels to “decouple” ceiling materials so they do not transmit noise; sound absorbant blankets in the floor assembly; spray-on cellulose or urethane foam; and the addition of mass, such as lightweight concrete or gypsum over a plywood floor. This last option requires extensive door and trim adjustments and the existing floor structure may not be able to support the additional weight.

ADVANTAGES: A variety of materials and techniques are available that, individually or in combination, can substantially reduce sound transmission.

DISADVANTAGES: Remedial techniques often involve the addition of new materials and can be costly; reduction of impact sounds in light-weight wood-frame buildings is very difficult.



FIGURE 16

INSTALLING FOAM GASKET

FURTHER READING

Fire Resistance Design Manual - Sound Control, Gypsum Association, 15th edition, 1997.

Gold Bond[®] Gypsum Construction Guide, 5th Edition, National Gypsum Company, 1998.

Gypsum Construction Handbook, 3rd Edition, United States Gypsum Company, 1994.

Noise Control Manual for Residential Buildings, David A. Harris, New York: McGraw-Hill, 1997.

Noise-Rated Systems, APA - Engineered Wood Association, 1994.

PRODUCT INFORMATION

SHEET CORK

Badger Cork, 26112 110th Street, P.O. Box 25, Trevor, WI 53179; 800-255-2675.

W.E. Cork, P.O. Box 276, Exeter, NH; 800-666-CORK; www.wecork.com.

SOUND CONTROL MATS AND ISOLATION PADS

Acoustic Surfaces, Inc., 123 Columbia Court north, Chaska, MN 55318; 800-854-6047; www.asi-stop.com.

AZKO Nobel Geosynthetics, Inc., P.O. Box 1057, Enka, NC 28728; 800-365-7391.

Integrity floor systems, Shadwell Company, Inc., 7207 Chagrin Road, Suite 6, Chagrin Falls, OH 44023

Kinetic Noise Control, Inc., 6300 Trelan Place, P.O. Box 655, Dublin, OH; 614-889-0480; www.kinetic-noise.com.

3

SHEATHING/ SUB-FLOORING AND UNDERLAYMENTS

3.1

DAMAGED SHEATHING/ SUBFLOORING

ESSENTIAL KNOWLEDGE

Until the late 1930s and early 1940s the typical residential floor sheathing was 1x6 and larger, straight-edged or tongue-and-grooved wood boards. These boards, laid perpendicular or diagonally to the floor joists, provided a level surface to which the finished floor was attached, and also acted as a diaphragm stiffening the floor structure and transferring lateral wind loads through the floor to the building's foundation. Occasionally, in rural areas, the floor sheathing became the finished floor as well, although shrinkage of the boards meant that, unless they were tongue-and-grooved, cracks developed between boards. By the early 1940s, with the introduction of waterproof adhesives, plywood floors began to replace board sheathing. By the 1960s a variety of other floor sheathing products came into use, including particleboard and waferboard. Early particleboard and waferboard did not perform well in high moisture situations and were, in turn, replaced with the stronger and more durable oriented-strand board (OSB) which, because of its lower cost, has replaced plywood in many areas.

TECHNIQUES, MATERIALS, TOOLS

REPAIR DETERIORATED OR DAMAGED FLOOR SHEATHING.

Deterioration of the floor sheathing, when it occurs, is often moisture-related, unless it is caused by foundation settlement, insect damage, earthquakes, or other natural disasters. It may be due to edge swelling, surface delamination, or buckling at panel joints from inadequate moisture protection during storage or construction, or it may be due to rot from roof or plumbing leaks. Corrective work should not be initiated until the cause of the deterioration is understood and corrected. Isolated repairs, typically in bathroom or other wet areas, usually entail cutting out and removing the finish floor and the damaged sheathing. If the existing sheathing shows minor damage, such as roughness, but is not decaying, it can be sanded smooth. The APA-Engineered Wood Association recommends a minimum of 11/32" underlayment be placed over lumber subflooring or uneven surfaces to provide a uniform surface. If sheathing is damaged and should be replaced, new sheathing should have a span rating that is appropriate to the framing spacing below.

ADVANTAGES: Localized repairs are cost-effective and relatively easy to make.

DISADVANTAGES: Requires the removal of finished flooring and often the existing sheathing. Costly over large areas.

ESSENTIAL KNOWLEDGE

Floor squeaks can originate in a variety of places, including between finished floor and sheathing, underlayment and sheathing, sheathing and joist, and joist and bridging. Floor squeaks often result from the rubbing of the sheathing against the shank of a nail that protrudes above the surface of the sheathing. This is often due to nail “popping” or “backout” from joist shrinkage or a gap created between the sheathing and the joist from the lack of a space between panels (the APA recommends a minimum of 1/8” gap on all panel edges) and subsequent buckling from expansion due to moisture (Fig. 1). Refastening the sheathing to the joist, after identifying the probable location of the squeak, can help eliminate it. There are several ways by which this can be accomplished.

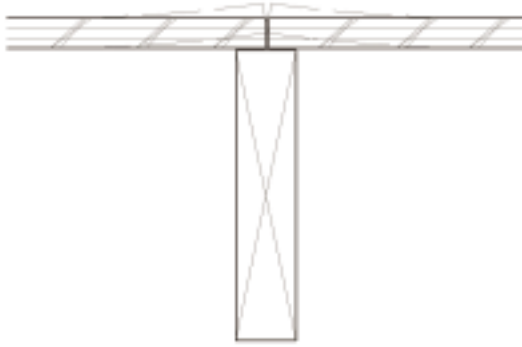

FIGURE 1

SHEATHING PANEL BUCKLING

TECHNIQUES, MATERIALS, TOOLS**1. APPLY ADDITIONAL SURFACE FASTENERS.**

Additional nails (preferably deformed-shank nails, such as ring or screw shank) or screws can be applied to the top of the sheathing or finished floor. Screws can be countersunk and concealed with wood plugs. Alternatively, an innovative tool, that includes an alignment device, for installing scored screws designed to break off below the surface of carpeted floors, is available from O’Berry Enterprises (Fig. 2). A less costly version is available for finished wood flooring.

ADVANTAGES: The least expensive and most direct approach. Does not require underfloor access. Stiffens floors that have been fastened with undersized fasteners, too few fasteners, or fasteners that have missed the joist below (relatively common with power-nailing since the operator has limited knowledge as to where the joists are).

DISADVANTAGES: Can affect the appearance of finished floors. Conventional screws can require removal of or cutting access holes through wall-to-wall carpet. Impractical for ceramic tile floors.

2. REFASTEN FLOOR SHEATHING TO JOIST FROM BELOW WITH LUMBER STRIP AND SCREWS.

This solution, recommended by the APA (Fig. 3), involves the use of wood blocking and a construction adhesive (where a gap exists) and floor loading to compress the adhesive. The APA recommends against the use of a shingle wedge to fill the gap between sheathing and joist as it may tend to lift the sheathing away from the joist on either side of the wedge and squeaks might result.

ADVANTAGES: Does not require fastening through top of sheathing or finished flooring.

DISADVANTAGES: Requires access from underside of floor.

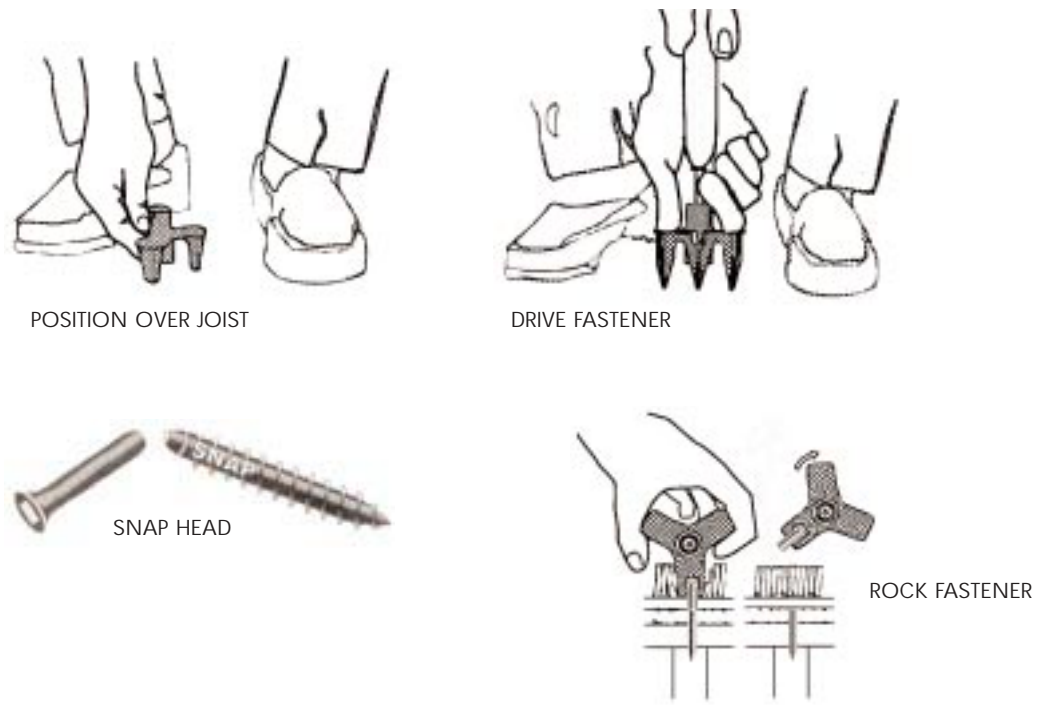

FIGURE 2 SQUEEEEEK NO MORE® SQUEAK ELIMINATION KIT

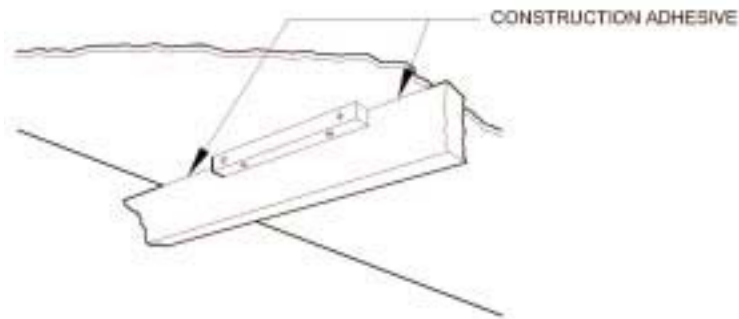

FIGURE 3 APA PLUMBER STRIP

3. REFASTEN FLOOR SHEATHING TO JOIST WITH SPECIALTY FASTENERS.

A line of specialty fasteners from E&E Consumer Products marketed as Squeak Ender™ and Seam Ender™ are specifically designed for under-floor application (Fig. 4) (see Product Information).

ADVANTAGES: Readily available at home centers. Relatively simple application that mechanically draws sheathing to joist.

DISADVANTAGES: Requires access to underside of floor joist and sheathing.



FIGURE 4 SQUEAK ENDER™

SEAM ENDER™ 23

4. RENAIL EXISTING BRIDGING.

Occasionally, the bottom of blocking or diagonal bridging has either not been nailed, or the nails have partially pulled out. As a result, the blocking or bridging, instead of transferring load to adjacent joists, tends to rotate and slide on the fastener, resulting in squeaks. Additionally, squeaks can occur under loading from foot traffic when adjacent pairs of bridging come into contact and rub together where they cross. These problems can be controlled by renailing existing fasteners, adding fasteners, and preventing bridging members from rubbing together.

ADVANTAGES: Simple fix if bridging is exposed.

DISADVANTAGES: May require removal of ceiling to access bridging. May not be possible if access is limited, such as in shallow crawl spaces.

5. ADD NEW BRIDGING.

Solid blocking or diagonal bridging can help prevent the joists from rotating when the floor above is loaded and can be effective in reducing squeaks in existing floors. Bridging or blocking can also assist in stiffening the floor. This is useful, particularly when the sheathing is too thin (which can cause it to deflect) or when the fastening of sheathing to joists is inadequate. A manufactured product (Sag-Ender™) is available to reduce sheathing deflection (Fig. 5) (see Product Information).

ADVANTAGES: A relatively simple fix.

DISADVANTAGES: Requires access to underside of floor. No guarantee that it will eliminate squeak.

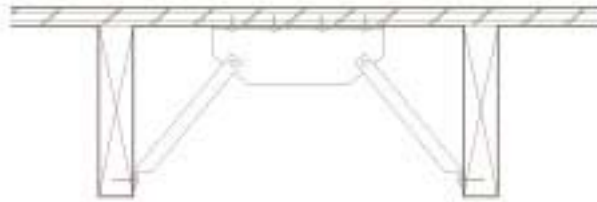

FIGURE 5

SAG ENDER™

6. ADJUST JOIST HANGERS.

When beams or joists are not properly fastened to their hangers or when the hangers are of the wrong width or height, the joist or beam (especially if it has shrunk) may be able to move freely in the hanger and can cause a squeak directly or indirectly by allowing the sheathing above to move. The beam or joist should be shimmed to fit tightly into the hanger and refastened (Fig. 6). If the hanger is the wrong size, it should be replaced with a properly-sized one.

ADVANTAGES: A simple but effective fix.

DISADVANTAGES: Requires access to the underside of the floor.

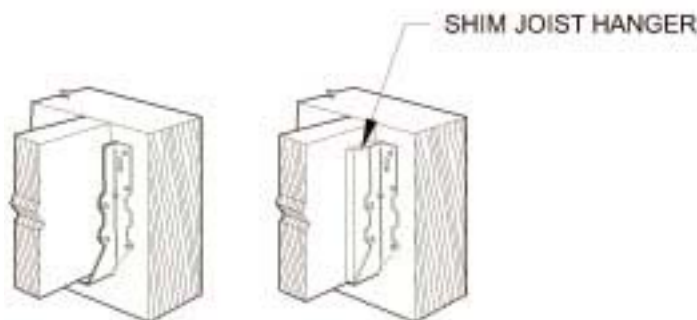

FIGURE 6

SHIM JOIST HANGER

3.3

7. ADJUST DUCTWORK WITHIN FLOOR CAVITY.

Heating/cooling ducts frequently run beneath the floor where they connect to floor registers. Floor squeaks can result when the hole cut in the floor for the register is too tight. A deflection of the floor near the register, from foot traffic, can cause a squeak. The heating ducts themselves may cause noise due to movement from expansion and contraction if not supported to allow for movement without rubbing against adjacent structure.

ADVANTAGES: A relatively simple fix.

DISADVANTAGES: Requires access to the underside of the floor.

UNDERLAYMENTS

ESSENTIAL KNOWLEDGE

Underlayments, typically plywood or cement board, and in some instances particleboard or hardboard, are used on top of floor sheathing and under vinyl tile, sheet vinyl, linoleum, and other materials that “telegraph” imperfections in rough, delaminated, or weathered floor sheathing/subflooring. They are also used under ceramic tile, especially thin-set tile. Underlayments are typically installed when a home is fully enclosed and protected from the weather. Existing underlayments may have been damaged by excessive wear or abuse due to deteriorating finishes above them, by moisture from excessive humidity, or by exterior or interior plumbing leaks. Flooring manufacturers and their industry associations make recommendations as to appropriate underlayments. These recommendations should be followed to assure that product warranties remain in force.

TECHNIQUES, MATERIALS, TOOLS

1. REPAIR EXISTING UNDERLAYMENT.

There is very little possibility of salvaging existing deteriorated, delaminated, or otherwise damaged underlayment. Localized deficient areas should be cut out, removed, and replaced with an appropriate material of equal thickness.

ADVANTAGES: Localized patching repairs are practical if the affected area is small.

DISADVANTAGES: Repair of underlayment necessitates the removal of the finished floor, which may be (as in the case of ceramic tile) very costly.

2. REPLACE EXISTING UNDERLAYMENT.

New underlayment should be used to replace deteriorated underlayment or used over existing underlayment, hardwood flooring, and resilient flooring, if those materials are basically sound. It should not be laid directly over existing ceramic tile floors without the addition of an appropriate sheathing below. Typically, underlayment material for hardwood or resilient flooring is plywood. Cement board is frequently recommended for ceramic tiles. The APA-Engineered Wood Association recommends a minimum of 1/4” plywood over smooth subfloors and 11/32” over lumber subfloors or uneven surfaces. Recommended grades for use under adhered carpet, resilient sheet goods and tile, and ceramic tile include: underlayment of C-C Plugged with sanded face; plywood or Com-Ply[®] Sturd-I-Floor (19/32” or thicker) with sanded face; Underlayment A-C; Underlayment B-C; Marine EXT; or sanded plywood marked “Plugged Crossbands Under Face,” “Plugged Crossbands (or Core),” “Plugged Inner Plies,” or “Meets Underlayment Requirements.” Other non-APA-rated plywood panels are frequently sold through supply outlets. These materials, including Luan plywood or other species, may not have plugged lamination or exterior glue and may be susceptible to deterioration from moisture when used in wet environments. Hardboard and particleboard are sometimes used, but are often not recommended because they can be

susceptible to swelling when wet. Specific materials and installation procedures should be reviewed with manufacturers and industry associations, such as the Tile Council of America.

ADVANTAGES: Appropriate new underlayment, properly applied, can provide a smooth base for finished flooring materials.

DISADVANTAGES: Appropriate underlayment can be relatively costly, may add height that causes difficulties with door clearance, built-ins, etc., and may require reducing strips between new and existing material.

FURTHER READING

“Application Instructions to Hardboard Underlayment,” *Basic Hardboard Products*, American Hardboard Association, July 1994.

Builder Tips: Steps to Construct a Solid, Squeak-free Floor System, APA Form Q300, APA - The Engineered Wood Association, P. O. Box 11700, Tacoma, WA 98411-0700; (206) 565-6600; www.apa.org.

Data File: Installation and Preparation of Plywood Underlayment for Resilient Floor Covering, APA Form L335.

Design/Construction Guide: Residential and Commercial, APA Form E30.

Handbook for Ceramic Tile Installation, Tile Council of America, Inc., 1999.

Proper Selection and Installation of APA Plywood Underlayment, APA Form R3400/Rev. October 1995/0010.

Source List: Plywood Underlayment for Use Under Resilient Finish Flooring, APA Form L330.

“Subfloors and Underlayments,” *Armstrong Guaranteed Installation Systems*, Armstrong World Industries, Inc., 1995.

PRODUCT INFORMATION

E&E Consumer Products, 7200 Miller Drive, Warren, MI 48092; 810-978-3800.

O’Berry Enterprises, Inc., 664 Exmoor Court, Crystal Lake, IL 60014; 800-459-8428; www.oberry-enterprises.com.

4

FINISH FLOORING

4.1

WOOD FLOORING

ESSENTIAL KNOWLEDGE

Wood flooring has been a traditional residential flooring material for hundreds of years. Its use diminished after World War II, however, with the introduction of plywood subflooring and underlayments, and the increased popularity of such less-costly alternatives as wall-to-wall carpeting and resilient flooring. In the last two decades wood floors have gained substantial new popularity as a “natural,” low maintenance, attractive, quality floor covering. As a result, there has been a recent proliferation of new manufacturers and products.

Types of wood flooring include: solid wood flooring, both hardwood (such as oak, maple, hickory, ash, cherry, and other domestic and imported hardwoods), and softwoods (including eastern white, southern yellow and ponderosa pine, Douglas fir, and hemlock); laminated wood flooring (comprising three to five veneers of wood and engineered wood products); and acrylic impregnated flooring (a very durable flooring available in both solid and laminated forms).

Styles of wood flooring include strip, plank, and parquet. Strip flooring is the most common, least costly flooring, typically 1 1/2”, 2 1/4”, or 3 1/4” wide oak. Plank flooring is common in hardwood in widths of 3”, 4”, 5”, and 6” with softwood flooring available up to 18” and sometimes wider. Plank flooring can be made straight-edged, tongue-and-grooved, or shiplapped. Wider sections are typically face-screwed and plugged, or with softwoods, face nailed with cut nails to restrict cupping and provide a traditional appearance. Parquet flooring is made up of small sections of solid or laminated wood that are combined to create geometric designs and patterns.

Aside from structural problems with the building’s frame, floor abuse, and overloading from furniture or occupants, most of the problems with wood floors relate to a lack of required maintenance or to the effects of high levels or changes in the moisture content of the flooring, sheathing, and underlayments. Changes in moisture content may be due to a variety of factors including: excessive moisture conditions in basements, crawlspaces, and under on-grade slabs (see Volume 1: *Foundations*); inadequate drying out of framing and finishes in new construction prior to the installation of flooring; inadequate or missing moisture retarders under slabs, in crawl spaces, or between sheathing and flooring; inadequate protection of flooring material; and leaks in the building’s envelope, plumbing, or mechanical systems. The best way to assure correct floor installations is to measure the moisture level of adjacent surfaces with a moisture meter. For radiant heat installations, the only sure way to dry slab and subfloor is to turn on the radiant heating systems before installing the wood flooring. When wood floors are not maintained properly, they can be refinished. Severe moisture changes, however, can lead to significant cracks, movement, cupping and/or buckling of floors.

TECHNOLOGY, MATERIALS, TOOLS

1. MAINTAIN WOOD FLOORING.

Weekly (or as necessary) vacuuming and/or dry dust mopping will remove grit and dirt that can scratch and erode floor finishes. If the finish is properly maintained, flooring will require only periodic refinishing, and will last almost indefinitely. A damp mop, cloth, or sponge can be used for spills and cleanup on non-waxed polyurethane or similar surface finishes, although care should be taken to keep the floor from

becoming too wet, as excessive water can seep between boards and into small scratches, causing deterioration of finishes. Small dents, where the wood fibers are not broken, can sometimes be removed by covering with a damp cloth and pressing with an iron to draw fibers up. Dark stains can sometimes be removed by lightly abrading the floor surface with fine sand paper and covering with a damp cloth containing 50/50 proportions of water and household bleach for 30 minutes. Let dry, recolor, and refinish if necessary. Waxed floors can be cleaned with paint thinner. Many manufacturers, particularly those that make laminated flooring, supply specially formulated cleaning products. Waxed finishes should not be cleaned with water in any form, as it can leave spots. Waxed floors should be buffed occasionally to redistribute the wax. Scatter rugs can be placed at entrances and areas of high traffic to reduce wear at those locations.

ADVANTAGES: Maintaining wood flooring properly is relatively simple and will reduce the need for refinishing and extend its life.

DISADVANTAGES: Even with continuing maintenance, wood floors will require periodic restoring or refinishing.

2. REPAIR DAMAGED WOOD FLOORS.

Floors that have rot, deep stains, bad gouges, or broken wood; or permanently cupped, warped, or crowned boards may not be able to be restored by normal sanding and refinishing. A common repair technique is to cut out the defective flooring using a skill saw and carbide-tipped blade. Clean cuts can be more easily made by nailing down a board temporarily as a straight edge (Fig. 1). After cutting, the defective section can be removed with a pry bar (and chisel if necessary), the sub floor repaired or replaced, and new flooring installed. A repair that can be effective on wide bulging boards that are to be painted or covered with carpet includes the application of a saw kirf/relief joint down the center of the bulge and subsequent screwing down of the sections of board adjacent to the saw cut.

ADVANTAGES: Repairs of small sections of flooring are cost effective and relatively simple.

DISADVANTAGES: Will not be effective if large sections of floor have been affected.

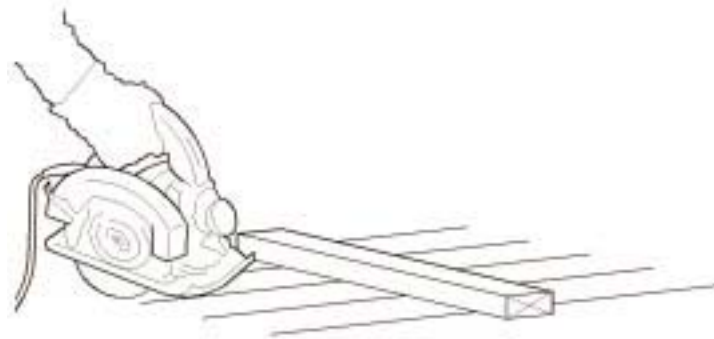

FIGURE 1

CLEAN CUT WITH NAILED STRAIGHT EDGE

3. STABILIZE AND REPAIR MOISTURE-DAMAGED WOOD FLOORS.

Solid wood flooring will contract during periods of low humidity (usually during the heating seasons) leaving cracks between flooring boards (a 2 1/4" wide strip oak floor can easily develop a crack the thickness of a dime, and wider boards will develop correspondingly wider cracks). Alternatively, flooring will expand during periods of high humidity. These cracks, more noticeable on bleached/white floors, are normal and usually not objectionable, and can be controlled by stabilizing the environment of the building through temperature and humidity control. Excessive moisture changes, however, can cause severe opening or expansion of flooring, which can lead to cupping, crowning, or buckling. Before strip flooring is installed, its moisture content should be within 4% of the subfloor below, and plank flooring should be within 2%, or excessive expansion or contraction can occur. For example, if buckling floors are treated early, several boards may be able to be removed, allowing air to circulate under the boards, particularly

if they are on sleepers. Once the floors have dried to a more stable condition, repairs can usually be made. In some cases, however, the flooring may have to be removed. Given normal conditions (70° F interior temperature and 40% relative humidity), a 5" oak board has a moisture content of 7.7%. If the relative humidity falls to 20%, the moisture content of the board will fall to 4.5% and the board will shrink by 0.059". Across 10' of flooring, this could amount to as much as 1.4". If the humidity were to rise to 65%, the board's moisture content would be 12% and the board would expand by 0.079". Across 10' of flooring, this could translate to 1.9". A burst pipe could cause buckling and render a floor unusable. Cupping and crowning are common problems that develop with high humidity (Fig. 2). Once the source of moisture is controlled, fans can be employed to assist in drying out the floor. Removing a strip of flooring against a wall may reduce pressure and assist in drying flooring. When this is accomplished the floor can be left as is or sanded and refinished if necessary.

ADVANTAGES: Minor moisture related damage may correct itself when the source is eliminated and the floor dries out.

DISADVANTAGES: Extensive moisture damage may involve sanding, refinishing, or removal and replacement.



FIGURE 2

CROWNED FLOOR

CUPPED FLOOR

4. SAND WOOD FLOORS.

When the surface of wood floors becomes scratched, worn, gouged, discolored, or distorted in profile, or if a new finish is desired, the appropriate step is to sand prior to refinishing. For hardwood floors, the National Oak Flooring Manufacturers Association estimates that a typical sanding will remove between 1/64" and 1/32" of wood. Tongue and groove, 3/4" oak flooring has 19/64" above the tongue. Therefore, a floor could theoretically be sanded and finished 6 to 10 times or more before the top of the groove is weakened. Under normal conditions, refinishing occurs at approximately 15-year intervals. This suggests that hardwood flooring, if not abused, can last as long as the structure. Softwood flooring will be affected to a greater degree by sanding, depending on the hardness of the wood. Great care should be taken to assure that the sander is not left stationary while it is on, as it will create ridges in flooring in a very short period of time. Recommended sanding and refinishing techniques are discussed in detail in the National Oak Flooring Manufacturers Association pamphlet entitled *Finishing Hardware Flooring* and other publications referenced in Further Reading.

ADVANTAGES: Spot or more extensive sanding can provide the opportunity to remove surface flaws without destroying the long-term performance of wood floors, especially hardwood floors.

DISADVANTAGES: An inherently messy operation requiring removal of all furnishings and protection of adjacent spaces. Can leave ridges and marks unless done carefully. Softwood floors can be sanded a very limited number of times.

5. REFINISH WOOD FLOORING.

Wood flooring that has been excessively worn, overloaded, abused or subject to water damage will have to be restored (sanded) and refinished. Wood flooring is available both prefinished, including acrylic impregnated, and site-finished. Recommendations for refinishing prefinished as well as site-finished flooring can be obtained from the manufacturer. Each floor finish has its advantages and disadvantages. Some of these are subjective, and there is no consensus on the best finish, especially since job conditions vary considerably. However, general attributes for the most popular finishes follow.

5.1 WATER-BASED URETHANES.

Water-based urethanes are usually combinations of urethanes and acrylics with a catalyst mixed prior to application. In general, the higher the percentage of urethane, the more durable and expensive.

ADVANTAGES: Contain fewer volatile organic compounds (VOCs) and are less noxious than other finishes. Clearer, less yellowing than other finishes. Good durability, fast drying, non-flammable. Becoming increasingly popular.

DISADVANTAGES: Somewhat less durable than other urethane finishes. Require more coats than solvent-based urethanes to achieve comparable film thickness (up to four coats). New coats may not adhere well to old coats.

5.2 OIL-MODIFIED URETHANES.

Oil-modified urethanes are technically oil-based; examples include linseed and tung oil.

ADVANTAGES: Until recently the most popular urethane finish and still favored by many users. Requires fewer coats than water-based methanes. Very durable and commonly available. Easy to recoat.

DISADVANTAGES: Imparts a yellower cast than other urethanes. Slow to cure and may require sanding between coats. High VOC contents, requires proper lung, eye, and skin protection. Combustible.

5.3 MOISTURE-CURED URETHANES.

Moisture-cured urethanes react with the humidity in the air to dry.

ADVANTAGES: Excellent durability. Provides the hardest wearing surface. Dries rapidly in moist environments. Recoatable.

DISADVANTAGES: Difficult to apply - should be left to professional finishers. Available only in glossy finishes. High levels of VOCs; requires careful lung, eye, and skin protection. Extremely flammable. Significant changes in humidity can lead to blistering or other defects.

5.4 "SWEDISH" FINISHES.

A type of finish, typically acid-cured (containing formaldehyde) and sometimes water-based, that produces high performing but expensive finishes.

ADVANTAGES: Excellent durability, transparency, and elasticity. A popular product among professionals. Recoatable, fast drying.

DISADVANTAGES: High VOC content and presence of formaldehyde in acid-cured formulas restricts application to professionals. Difficult to apply and requires carefully sanded floor. Combustible.

5.5 OIL FINISHES.

Most penetrating oil sealers/finishers are combinations of highly modified natural oil, such as linseed or tung oil, with additives to improve hardness and drying. Adding wax to oil-finished floor will afford protection against spills and abrasion, although the manufacturers of some finishes such as Velvit™ oil maintain that their products do not require wax.

ADVANTAGES: Easy to apply and repair (just brush or rub on another coat). Good durability. Will not crack, craze or peel. Low luster - popular with installers and users of traditional softwood flooring.

DISADVANTAGES: Not as durable as other finishes. Can take a long time to completely cure. Surface may collect dust. Can water-spot. Some finishes require waxing. Strong initial odor. Combustible.

5.6 WAXES.

With the increased use of urethane finishes, waxes (typically paste waxes) are not as common as they once were. Most manufacturers of urethane finishes do not recommend the use of waxes over urethanes because of added maintenance. Waxed surfaces require a stain or grain sealer prior to waxing.

ADVANTAGES: Protects and extends life of oil finishes. Easy to apply and surprisingly durable. Fast drying.

DISADVANTAGES: Requires maintenance (touch-up, buffing, and periodic removal with wax removers or sanding, and rewaxing). Becomes brittle and can yellow flooring. Can be slippery when wet - not suggested in kitchens, entryways, or bath/powder rooms. Contains VOCs; strong initial odor; can water-spot.

6. REPLACE OR RECOVER WOOD FLOORS.

Flooring may have cupped, split, buckled, or deteriorated to the point where it has to be replaced. The type of replacement flooring can be similar to that removed or may be another material, such as laminated flooring, which is less susceptible to moisture, or another wood species considered more visually appropriate. The wide range of choices can be clarified by reading reference material or contacting industry associations and individual manufacturers (see Further Reading).

ADVANTAGES: Replacing or recovering flooring may provide a chance to install more appropriate material.

DISADVANTAGES: Disruptive and expensive.

FURTHER READING

Finishing Hardwood Flooring, National Oak Flooring Manufacturers Association, March 1998.

Flooring Grade Brochure, National Oak Flooring Manufacturers Association, March 1998.

Hardwood Floors - Laying, Sanding and Finishing, Don Bollinger, Newtown, CT: Taunton Press, 1990.

Installing Hardwood Flooring, National Oak Flooring Manufacturers Association, March 1998.

Problems Causes Cures, National Wood Flooring Association, May 1991.

Water and Wood - How Moisture Affects Wood Flooring, National Wood Flooring Association, 1996.

Wood Floor Care Guide, National Oak Flooring Manufacturers Association, Nov. 1997.

Wood Flooring - A Lifetime of Beauty, National Wood Flooring Association.

Wood Species Used in Wood Flooring, National Wood Flooring Association, Technical Publication A200, 1994.

PRODUCT INFORMATION

HARDWOOD MANUFACTURERS

Buyer's Guide - Directory of Companies, National Oak Flooring Manufacturers Association, 1998 (list of Association members and their products).

PREFINISHED AND LAMINATED WOOD FLOORS

Anderson Hardwood Floors, P.O. Box 1155, Clinton, SC 29325; 864-833-6250; www.andersonfloors.com.

Bruce Hardwood Floors, P.O. Box 660100, Dallas, TX 75248; 800-527-5903.

Harris-Tarkett Hardwood Floors, P.O. Box 300, Johnson City, TN 37605-0300; 800-842-7816; www.harristarkett.com.

Hartco Flooring Co., P.O. Box 4009, Oneida, TN 37841; 423-569-8526; www.hartcoflooring.com.

Robbins Hardwood Flooring, 25 Whitney Drive, Suite 106, Milford, OH 45150; 800-733-3309.

Zickgraf Hardwood Company, P.O. Box 1149, Franklin, NC 28744; 828-369-9156; www.zickgraf.com.

ESSENTIAL KNOWLEDGE

Vinyl sheet flooring and tile are probably the most popular choices for kitchen and bath floor coverings in homes across the U.S. Although the sheet vinyl material available today is sometimes referred to as linoleum, it differs from that material. Linoleum contains cork, wood products, and oleoresins, while resilient sheet material contains vinyl resins with a fiber back. Today's sheet vinyl material provides a soft cushioned walking surface that is not associated with linoleum-covered surfaces. Resilient sheet vinyl flooring and vinyl tile are a low-cost, easy-to-install flooring option. They are available in styles and patterns that can satisfy any taste and blend well with any home's decor. Although usually found in kitchens, laundries, and baths, they can be installed anywhere in the home. Manufacturers have made the job of tile installation easy with adhesive-backed tile that does not incur the mess, expense, and extra time associated with adhesive applications.

Resilient vinyl flooring and linoleum installed in homes from the 1920s through the 1980s was manufactured with asbestos. Even though some flooring still contains small amounts of asbestos, most manufacturers have eliminated it from their manufacturing process. As some resilient vinyl flooring or linoleum wears, asbestos-containing fibers can be released into the air causing a potential health risk. Sheet goods and resilient tile contain a polymer-like top layer and a second, fibrous layer that may contain up to 40% chrysotile asbestos. This asbestos is released into the air only when the fibrous layer becomes agitated. Since the asbestos is very tightly bonded to the polymer-like top layer, there is minimal potential health hazard if the fibrous layer is not damaged. Extreme caution and professional help should be used when removing asbestos-containing tiles. Although this chapter focuses on rehabilitating vinyl sheet flooring and tile, the same techniques can be applied to rehabilitating linoleum floor coverings.

TECHNIQUES, MATERIALS, TOOLS**1. REMOVE STAINS FROM SHEET VINYL AND VINYL TILE FLOORING.**

If vinyl floor surfaces have yellowed or have become stained with age, contact a professional floor-refinishing contractor or the manufacturer for cleaning recommendations. Using household bleaches or dyes to clean stains on vinyl materials may dull or damage surfaces. Sometimes resilient flooring may be installed incorrectly, leaving gaps between tiles or sheet-flooring seams, or gaps between tiles or sheets and appliances or cabinets that may be too wide. Dust and dirt may settle into these gaps. If grime has accumulated in these gaps, a soft tooth brush can be used to gently loosen dirt particles. If the dirt will not loosen, a pin can be used to clear dirt from gaps or seams.

ADVANTAGES: Because resilient sheet goods and tile are moisture resistant and non-porous they are an easily maintained floor-covering option.

DISADVANTAGES: Improper cleaning methods and agents can mar vinyl surfaces beyond repair.

2. REPAIR VINYL FLOOR COVERING.

Resilient vinyl sheet flooring and vinyl tiles may tear or puncture if proper care is not taken to protect floor surfaces. Moving appliances over an unprotected vinyl floor surface is one of the most common causes of surface damage. Any type of rip or tear should be repaired to prevent further damage. The best way to repair ripped or torn resilient flooring is by cutting out the damaged section and replacing it with a matching patch (Fig. 3). This can be accomplished by cutting around the damage along the pattern lines. Using the pattern lines as a guide for cuts will conceal the repair. Remove a matching patch from an inconspicuous area of the room—under cabinets or appliances is usually a good place. Repair damage to a non-patterned floor using the same technique. Because the seams may appear more obvious when patching non-patterned flooring, be sure to keep the cutout as small as possible. Once the damaged piece is removed, use mineral spirits to remove the old adhesive from the matching patch. Apply the new adhesive

to the patch and fit it into place. Use a roller or rub with a cloth to ensure proper adhesion. Place a heavy object over the new patched area until the adhesive is set.

ADVANTAGES: Repairs to vinyl floor coverings are relatively quick and easy using a matching patch cut from a hidden area of the room.

DISADVANTAGES: Cutting out the damage to non-patterned floor coverings and replacing it with a matching patch may reveal seams. Matching patches may not be available.

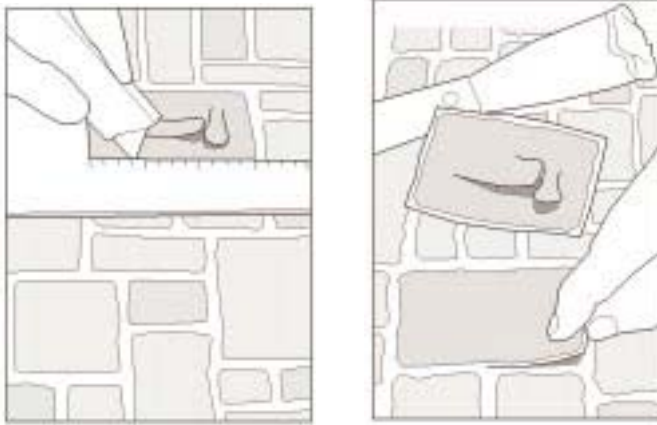

FIGURE 3

REPAIRING VINYL FLOORING

3. REPLACE VINYL FLOOR TILE.

Cracked, torn, or badly-stained vinyl floor tile should be replaced. If a matching tile is not available, remove a tile from an inconspicuous area, under kitchen appliances or inside pantry closets, for example. A dry removal of tile, which involves cracking the material and lifting the pieces off the floor with a scraper, may release asbestos fibers into the air, so proper precaution must be taken. Removing tiles in one piece using solvents to loosen any adhesive will not break the asbestos-containing fibrous layer and greatly reduces any health risk. If it is uncertain whether or not the tile contains asbestos, consult a flooring professional for advice on proper removal and repair.

Use a heat gun or hot iron over the damaged tile to loosen the adhesive, and pry up the tile with a putty knife (Fig. 4). If it does not lift off easily, continue to apply heat and pry again. Another technique is to place a pan of ice cubes over the tile until the adhesive becomes brittle and the tile pops out. However, this process may cause some tiles to crack and release asbestos-containing fibers into the air. Remove the adhesive from the underlayment where the damaged tile was removed and from the underside of the matching patch tile. Mineral spirits and a scraper will remove all adhesive. Apply new adhesive to the underlayment and fit the replacement tile in place. Use a roller or rub with a cloth to ensure proper adhesion. Place a heavy object over the patched area until the adhesive is set. Clean excess adhesive with a damp cloth.

ADVANTAGES: Damaged resilient floor tiles can be easily and inexpensively replaced.

DISADVANTAGES: Matching tile may be difficult to locate. Asbestos particles can be released into the air if proper precautions are not taken.

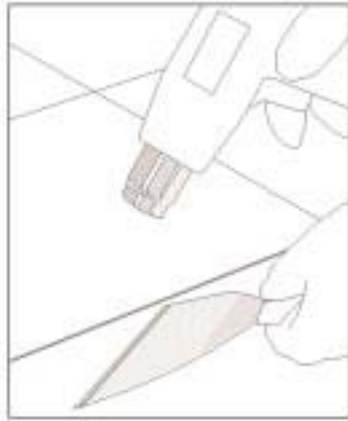

HEAT GUN AND BLADE
TO REMOVE TILE

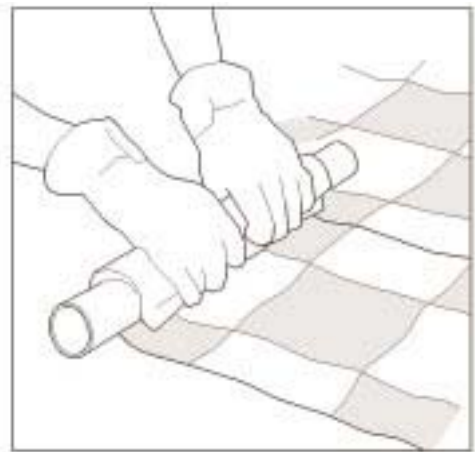

ROLLING UP SHEET FLOORING

FIGURE 4, 5

4. REMOVE RESILIENT TILE AND SHEET GOODS.

Resilient vinyl tile and sheet goods can be removed if damage is beyond repair or if it is not properly bonded to the subfloor. Vinyl wall base is removed by using a heat gun and a putty knife and gently prying it from the wall. For tile, a heat gun can be used to direct heat over the material to soften old adhesive and pry tiles from the subfloor using a putty or spackle knife. The old adhesive should be scraped from the subfloor. Floor scrapers with long handles are available that allow the old adhesive to be scraped from the subfloor from a standing position. To remove linoleum or sheet goods begin by using a utility knife to slice the flooring in strips 10" to 12" wide, which can be peeled away. A paint-roller tube is a handy tool to wrap the strips around as they are peeled (Fig. 5). The top layer of some cushioned sheet goods may separate from the backing during removal, leaving it adhered to the subfloor. This can be removed with a soap-and-water solution to loosen the backing from the subfloor and scraping it.

ADVANTAGES: Removing resilient flooring will ensure proper adhesion of the new floor.

DISADVANTAGES: Can be a time-consuming job. Old vinyl-asbestos tile or linoleum may break in the process, causing asbestos fibers to be released into the air.

5. INSTALL RESILIENT VINYL TILE.

Resilient vinyl tile is either "solid" vinyl or "through-pattern" vinyl. Solid vinyl tile is made of vinyl resins that make up approximately 60% of the material's weight. Through-pattern vinyl tile is made of thermoplastic binders, fillers, and pigments, and is less costly than solid vinyl. This tile is commonly available in 9" or 12" squares, either self-sticking or adhesive-applied.

Begin tile installation along perpendicular layout lines by dry-fitting the tile to make sure that the pattern is suitable. Start in the center of the room and work toward the walls leaving about a 1/4" expansion gap between tile and walls.

ADVANTAGES: Quick and easy installation.

DISADVANTAGES: An unprofessional appearance will result if tiles are not installed along straight lines.

6. INSTALL RESILIENT SHEET FLOORING.

Sheet material is usually available in 6', 9', 12' and 23'-wide rolls and is either inlaid, rotovinyl, or modified rotovinyl. Inlaid, the most costly choice, has an integral pattern or color from the surface through the backing. Rotovinyl sheets have a backing that is covered with a foam layer on which a patterned coat of vinyl is applied. A protective top layer is applied to the printed layer. It is the thickness of this top layer that determines its durability. Modified rotovinyl sheets have chips of color that are spread between the printed and top layers. Because it lacks the durability and color quality of its counterparts, it is the least costly choice. When installing sheet flooring try to locate seams in inconspicuous areas of the floor. To minimize cutting errors, make a template of the floor to be covered using sheets of paper taped together and to the floor along the perimeter of the room. Transfer the template to the unrolled sheet flooring, trace the outline of

the template, and carefully cut along the template lines. Be sure to locate seams along pattern lines. Staple to the floor along one edge of the sheet. Begin applying adhesive as necessary, working from the stapled edge toward the room's interior. Use a roller to bond the sheet to the floor.

ADVANTAGES: Seams are virtually invisible, providing a smooth, uniform appearance.

DISADVANTAGES: Time-consuming installation.

FURTHER READING

Installing Vinyl Flooring, Hometime, Chaska, MN, 1994.

Armstrong Guaranteed Installation Systems, Armstrong World Industries, Inc., Lancaster, PA, 1998.

PRODUCT INFORMATION

US EPA Indoor Air Quality Information Clearinghouse, PO Box 37133, Washington, DC 20013-7133; 800-438-4318; www.epa.gov/iaq.

Congoleum, PO Box 3127, Mercerville, NJ, 08619; 609-584-3000; www.congoleum.com.

Armstrong World Industries, Inc., PO Box 3001, Lancaster, PA, 17604-3001; 800-292-6308; www.stickwithus.com.

Amico International, Inc., 6480 Roswell Rd., Atlanta, GA, 30328; 404-267-1900.

Fritz Industries, Inc., PO Drawer 17040, Dallas, TX, 75217; 972-285-5471; www.fritztile.com.

Marley Floors Inc., PO Box 553, Tuscumbia, AL, 35674; 800-633-3151; www.marleyflexo.com.

Mercer Products Company, Inc., PO Box 1240, Eustis, FL, 32727-1240; 800-447-8442.

4.3

CERAMIC TILE

ESSENTIAL KNOWLEDGE

Because it is impervious to water, ceramic tile has traditionally been used as a floor finish in damp areas such as bathrooms, kitchens, basements, and entryways. Because of its relative durability, low maintenance and decorative qualities, ceramic tile is increasingly used in other spaces as well. Typical installation methods include: thick-set (the most traditional method, sometimes called mud-set), set in 3/4" to 1 1/4" of Portland cement paste/mortar laid over a previously set mortar bed or concrete slab; and thin-set, set in an organic or epoxy adhesive. Ceramic tile is divided into glazed and unglazed varieties. Most historic floor tiles were unglazed and were the color of the clay and added oxides or pigments from which they were made (current examples are quarry tiles). Glazed tile is colored with a variety of glossy or mat glazes applied to the tile surface. Glazed tile is subject to scratching and abrasion from extended use and is usually installed in low traffic areas or covered with rugs. Tile failures are caused by a number of factors: improper maintenance, including the use of inappropriate cleaning agents or the degenerative effects of standing water on the grout, and the erosion of grout over time from traffic and cleaning. Structural problems can also cause failure. These include cracking and loosening of tile from overloading, sudden impacts, or frequent vibrations; defective or deteriorated substrates, such as concrete floors that have cracked, heaved, or settled; wood floor substrates that deflect excessively (too springy), have buckled, swelled or deteriorated; and concrete or wood floors that have improperly mixed or applied tile bonding materials.

TECHNIQUES, MATERIALS, TOOLS

1. MAINTAIN/RESTORE CERAMIC TILE.

When properly specified and applied, ceramic tile requires relatively little maintenance other than damp mopping or vacuuming. Normal cleaning is done with a neutral pH cleaner designed specifically for ceramic tile. Tile and floor covering stores sell cleaning products developed specifically for cleaning tile. These specialized cleaners generally outperform products available in supermarkets or hardware stores. Most glazed tile does not require sealers, but some tile such as quarry, saltillo, and others do. Sealers are also used to protect grout joints. Use cleaners and sealers recommended by the manufacturer or sealers designed specifically for ceramic tile. Restoring or rejuvenating existing tile may involve the removal of deep stains, grease, oil, or various coatings and sealers. The Tile Council of America (TCA) recommends non-flammable, non-acid, methylene chloride-based solvents. If the cleaning is extensive, a company experienced in this work should be employed. The TCA-recommended cleaners are used to remove stains, such as light haze of grout. Acid will not remove heavy grout stains, oil, grease spots, or paint. Sulfamic acid does not give off noxious or damaging fumes. The use of muriatic acid is not advised, as it can erode tiles and grout joints and it can cause serious skin burns and internal injuries to individuals using it. While glazed tile used for countertops or kitchen floors must be able to resist etching from vinegar and citric acid, it may not resist bottled acid containing sulfamic and phosphoric acids. Muriatic acid should not be used in any case. Acid, if it is used, should be completely removed by continuous scrubbing and rinsing with clean water. Adjacent surfaces and materials should be protected.

ADVANTAGES: Some cleaners are relatively inexpensive and easy to use.

DISADVANTAGES: Cleaning large areas or the use of professional cleaners or acids should be undertaken by floorcare experts.

2. REPLACE LOOSE, CRACKED, OR DAMAGED CERAMIC TILE.

Assuming that the substrate is satisfactory, the loose, damaged, or cracked tiles should be removed. If necessary, the grout joint can be carefully cut out with a grout saw, carbide or diamond-tipped saw blade. The tile can then be chiseled out to reduce the risk of damage to adjacent tiles. If the substrate is concrete, the surface of the concrete can be scarified (scratched) using a cup grinder or other appropriate tool to remove any old bonding agents. Installation of reused or replaced tiles and mortar joints should be in accordance with the TCA's *Handbook for Ceramic Tile Installation*, or individual manufacturers' recommendations (see Further Reading).

ADVANTAGES: For small areas, a relatively inexpensive and easy fix.

DISADVANTAGES: Requires careful use of cutting tools; materials can easily be damaged.

FURTHER READING

Acids and Acid Cleaning - Friend or Foe, Field Report, Tile Council of America, 1985.

Cleaning and Repointing Old Tile Installations, Tile Council of America, 1985.

Maintaining A Tile Installation, Field Report, Tile Council of America, 1986.

Caring for Your Ceramic Tile, Tile Council of America, Inc., 1996.

Handbook for Ceramic Tile Installation, Tile Council of America, Inc., 1997.

ESSENTIAL KNOWLEDGE

For many rehab applications, carpeting presents a low-cost, easily installed solution to flooring problems, and it can cover a multitude of sins. Existing carpet may be salvageable if wear and tear is not extensive. Today, carpet is available in a variety of designs and materials that extend the life of this popular floor covering.

TECHNIQUES, MATERIALS, TOOLS**1. MAINTAIN CARPET.**

Carpeting can collect dust, pesticides, pet dander, and other allergens, and can be a breeding ground for dust mites under certain temperature/humidity combinations. If a carpet becomes wet and is not dried thoroughly within 24 hours, it can support mold and mildew, resulting in unpleasant odors and possible allergic reactions from occupants. Also, among health concerns are the affect on people with allergies of high levels of volatile organic compounds (VOCs) given off by some carpet backing material, especially older types of installation adhesives. In addition, carpeting, because of its soft, fibrous nature, has the ability to absorb VOCs from the environment (such as paint, cleaning products, smoke from cigarettes, building materials, and furnishings), and slowly re-release them over time. Carpet manufacturers are increasingly conscious of these issues and most provide new carpets with low or no VOCs. A carpet should be vacuumed regularly, and to retain its luster and attractiveness, it should be cleaned every 12 to 18 months or before it shows significant soiling. Refer to the carpet manufacturer's warranty for recommendations for appropriate cleaning methods. The Carpet and Rug Institute (CRI) has recommendations for the selection of professional carpet cleaners (see Further Reading). Carpets that have sustained prolonged water damage will most likely have to be replaced in their entirety. Rugs and carpeting must be vacuumed regularly with a strong, well-functioning vacuum cleaner. Most new carpet is protected with special finishes such as 3M's Scotch Guard™ to resist soil and stains. These finishes hold the spill on the fiber's surface, allowing the liquid to be removed before penetrating the fiber. The longer the stains are left, the more difficult removal will be. Stains should be blotted with a soft, white absorbent cloth or paper towel from the spot's edges towards the center. Use clean water to remove remaining cleaning agent and absorb remaining moisture with paper towels. A comprehensive guide to spot removal is found on CRI's website: www.carpet-rug.com/athome/default.htm.

ADVANTAGES: Continuous, timely maintenance will prolong the life of carpets.

DISADVANTAGES: All carpet has limited lifetime based on use.

2. RESTORE WATER-DAMAGED CARPET.

Determine whether the water is sanitary (uncontaminated sink or toilet overflows), grey water (some degree of biopollutant contamination including punctured water beds, dishwasher overflows, contaminated sink water), or black water (water that has come into contact with the ground or that contains raw sewage). Only carpet damaged by sanitary water can be treated non-professionally. Cleaning professionals should handle carpet damaged by unsanitary or black water, as it may harbor disease-carrying bacteria. Carpet damaged by black water must be discarded. The CRI and the Institute of Inspection, Cleaning and Restoration Certification (IICRC) have toll-free telephone numbers and can provide additional restoration information (see Further Reading).

ADVANTAGES: Carpet subject to uncontaminated or "grey water" flooding may be able to be restored.

DISADVANTAGES: Restoration may not be cost-effective.

3. REPAIR STAINED CARPET.

Isolated damage to carpet, such as stains and burns, can be removed and patched. If the damage is small, locate a matching piece of carpet from an inconspicuous location (inside closets for example). Cut out the

damaged area using a straight edge and a utility knife. Transfer the measurements of the cutout onto the spare piece of carpet. Cut the patch to size, coat with carpet adhesive or apply double-sided carpet tape, and position. If the damage is extensive, consider removing a large section of carpet from the nearest seam to a wall or door jamb. If a matching piece of carpet cannot be located, consider taking a swatch to a home center or a carpet manufacturer who may be able to order a matching piece. Carpet discolored from bleach or household cleaners can be restored if the carpet fibers are not damaged. Professionals can spot-dye carpets or remove them from the home and dye them in the factory, restoring them to their original color and condition. **ADVANTAGES:** Patching isolated problem areas will restore the carpet's appearance.

DISADVANTAGES: A matching patch may be hard to locate. Professional carpet dyeing, cleaning, and restoration services may not be cost effective.

4. RESTORE CARPET FROM SMOKE DAMAGE.

Carpet damage from smoke usually requires a more extensive treatment than that for small burns or stains. As a result of smoke, dry soot settles on the carpet and penetrates the fibers. The content and amount of the soot depends on the fire's source and burn rate. Strong odors usually accompany any smoke or fire damage. Proper ventilation will help eliminate these odors, although unless the carpet is cleaned, the odor may persist. While smoke residue can be cleaned by a professional carpet cleaning or restoration professional, any burnt areas must be removed.

ADVANTAGES: Smoke-damaged carpet can be restored to its original condition if there is no damage to carpet fibers.

DISADVANTAGES: Extreme smoke damage may require removal and factory cleaning. Damage to carpet fibers may require replacement.

5. INSTALL CARPET OVER DAMAGED FLOORS.

Installing carpet over damaged floors is a cost-effective way to enhance the floor's appearance. If the damage to the existing floor is extensive (a cracked concrete slab, for example) higher-pile carpet, such as Saxony or plush styles, usually work best. Low-pile carpet, such as Berber or level loop, are less apt to mask extensive damage. If floor damage is slight, any style of carpet will work. Be sure to check the manufacturer's recommendations for installing carpets over damaged floors. Some carpet will require underlayment, although many may be installed without it. In some cases, a latex patching compound can be used to even out floors for carpet installation.

ADVANTAGES: Installing carpet over damaged floors will enhance their appearance.

DISADVANTAGES: May not be a cost-effective solution if underlayment is required.

FURTHER READING

Carpet: Installation and Maintenance for Maximum Performance, Carpet and Rug Institute, 1998.

CRI-104 Installation Guidelines, Carpet and Rug Institute, 1996.

Environmental Resource Guide, American Institute of Architects, New York: John Wiley & Sons, Inc., 1997.

General Restoration Guidelines for Water-Damaged Carpet, Carpet and Rug Institute, 1998.

How to Hire a Carpet-Cleaning Professional, Carpet and Rug Institute, 1998.

Standard Reference Guide for Professional On-Location Cleaning of Installed Textile Floor Covering Material, Institute of Inspection, Cleaning and Restoration Certification, 1991.

5

FINISH WALL & CEILING MATERIALS

With the exception of solid wood paneling found in high-end housing or various forms of plywood paneling, the dominant wall material has been plaster or, since the 1960s, gypsum board (typically known as drywall, wallboard, and “sheetrock,” which is a trademarked name for US Gypsum’s gypsum board). Damage to wall and ceiling surfaces can result from a variety of causes, including wood shrinkage, under-sized structural framing, building settlement, impacts and vibrations, high winds or seismic events, moisture, fire, and insects. This section will review various wall and ceiling materials, finishes, and trim, and typical problems and corrective measures.

5.1

PLASTER AND DRYWALL

ESSENTIAL KNOWLEDGE

Assuming they have been properly applied, the most common damage to older plaster ceilings is from the breaking of the plaster “keys” that attach the plaster to the supporting wood lath. This is typically caused by deflection from shrunken, warped, or inadequately sized joists and rafters, heavy vibrations from foot traffic on the floors above, construction activity including the cutting in of plumbing lines and the installation of new wiring and recessed lighting, or softening of the plaster keys from moisture infiltration. This can lead to a particularly dangerous situation, as the condition of the plaster keys is not visible, and instances of the entire ceiling separating from the ceiling lath and falling to the floor below are not uncommon. Damage to wall surfaces is less serious, and if some of the plaster keys have split, it is usually not a serious problem.

In general, the least expensive and most desirable way to repair old plaster wall and ceiling surfaces is to carefully patch and then paint or (in the case of walls) wallpaper them. Covering cracked or deteriorated walls with an additional layer of gypsum board or paneling is the next least expensive option. By far, the most expensive option is to tear out old plaster in its entirety and replace it with new drywall and trim. The Enterprise Foundation, a non-profit organization that has extensive rehab experience, has found that it is less expensive to repair up to 50% of walls and ceilings that have otherwise sound plaster, than to remove all the existing plaster and replace it with drywall. One reason for this is that the studs in old walls are typically uneven and will require extensive shimming or furring before new drywall can be applied. In addition, the existing trim will likely have to be replaced, which is labor-intensive and expensive.

Damage to existing drywall can be caused by structural or moisture-related problems, but may also be caused by abuse or daily wear and tear. Drywall is thinner than plaster (1/2” or 5/8” rather than 3/4”) and spans greater unsupported distances, typically 16” to 24” on interior partitions. The following highlights some of the repair techniques for both materials.

TECHNIQUES, MATERIALS, TOOLS

1. REFASTEN BOWING OR DEFLECTING PLASTER.

Plaster, if it has separated from its metal, gypsum, or wood lath base, is difficult to repair and requires extreme care, especially in ceilings, to assure that the remedial work secures the plaster adequately. Stabilization methods include the use of plaster washers, 1" galvanized metal disks that are screwed into the wood lath and preferably into the joists above at spacing that varies with job conditions. The metal washers can be counter-sunk into three-coat plaster using a 1 1/4" spade bit or can be left surface-mounted. The metal plaster washers are tightened against the lath or joists, covered with fiberglass tape, and skim-coated with plaster or gypsum drywall joint compound (Fig. 1). A more sophisticated technique, used for reinforcing the bond between the lath and the plaster in historic restoration, or where preserving ornamental plaster detailing is important, was developed by the Society for Preservation of New England Antiquities (SPINEA) and is currently employed by a few restoration contractors. This system, which requires access from above, comprises the drilling of two or three 3/16" holes into each lath between joists over the ceiling surface. The holes penetrate the lath and not the plaster scratch coat. After the sawdust is vacuumed away, a pre-wetting solution of water, alcohol and acrylic adhesives is injected into the holes. Additional acrylic adhesive is then injected under pressure which causes the adhesive to travel along the interface between the scratch coat and the wood lath forming a continuous bond when it hardens (Fig. 2).
ADVANTAGES: Plaster washers and acrylic adhesives can stabilize existing ceiling and wall plaster. Helps preserve architectural details, and saves the cost of new plaster or gypsum board.
DISADVANTAGES: Does not eliminate underlying deflection problems. Locating structural members to screw plaster washer may be too difficult and time-consuming. Acrylic adhesive restoration must be undertaken by professionals, is expensive, and requires access to the wood lath.



FIGURE 1

PLASTER REPAIR WITH WASHERS

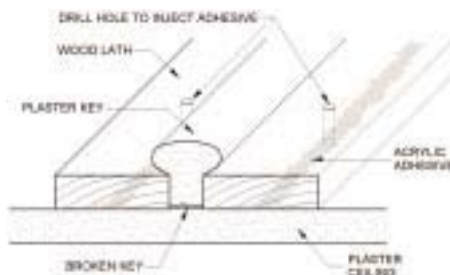

FIGURE 2

ADHESIVE INJECTION TECHNIQUE

2. REFASTEN BOWING OR DEFLECTING DRYWALL.

Drywall that has pulled away from studs or joists can typically be refastened, unless the paper face is severely damaged or the gypsum material is crumbly, in which case it should be replaced. Fasteners for wood studs and joists include nails (ring shank hold better than plain shank), or preferably screws which do less damage to the paper facing and hold the gypsum board tighter against the framing. Screw heads should sit just below the surface of the paper face without tearing it. Nails should be set in a shallow dimple, but not so deep that they break the paper and damage the gypsum core (Fig 3).

ADVANTAGES: Drywall, if it is sound, can be refastened relatively easily.

DISADVANTAGES: If the surface is significantly cracked or the gypsum core has been damaged, refastening may not be adequate and that section may need to be replaced.



FIGURE 3

REFASTENING DRYWALL

3. REPAIR CRACKS AND HOLES IN PLASTER.

If the cracks are minor and not the result of structural problems, which should be corrected prior to repairs, the repairs are relatively simple. Plaster cracks can be cut out, coated with a bonding agent such as polyvinyl acetate (PVA), and filled with patching plaster or drywall joint compound. Or they can be covered with self-adhering fiberglass mesh tape which does not require a bedding compound, and covered with drywall joint compound (Fig. 4). Larger holes should be cleaned of loose material, metal lath affixed to the substrate, the bonding agent applied, and the holes replastered. Some patches may require complete plaster mixes, including scratch, brown, and finish (white) coat.

ADVANTAGES: Holes and cracks in plaster are relatively easy to repair with conventional techniques and materials.

DISADVANTAGES: Large sections of walls requiring repair may need laminating with new drywall or complete removal and replacement with new materials.

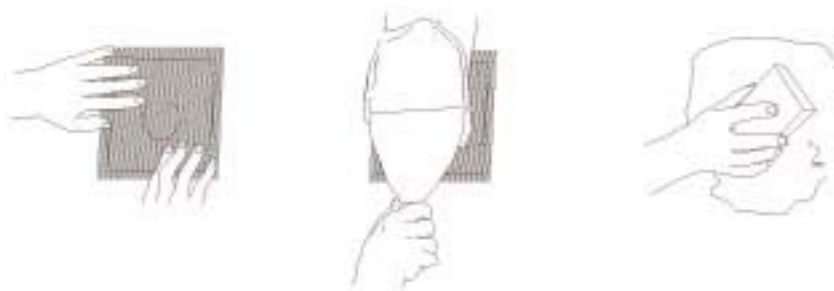

FIGURE 4

MESH TAPE AND JOINT COMPOUND

4. REPAIR SMALL HOLES, CRACKS, DENTS, AND POPPED NAILS IN DRYWALL.

Small holes and dents are typically caused by impacts from furniture or other sharp or heavy objects. Repairs to larger sections are often due to structural or moisture problems. To repair small holes, cracks, and dents: wipe the area clean, fill with joint compound using taping knife, let harden, add second coat if

necessary, sand and prime when dry. Nail pops occur when a stud shrinks or twists, leaving a space between the stud and the drywall. When pressure is applied against the drywall, it is forced against the stud, causing the nail head to protrude beyond the face of drywall (Fig. 5). To repair a popped nail: drive and dimple a new nail 1 1/2" from popped nail, Drive and dimple the popped nail, cover with joint compound, sand and prime when dry.

ADVANTAGES: Simple repairs that do not require special skills.

DISADVANTAGES: Joint compound may not adhere well; repair may require application of fiberglass or paper tape as well as compound.



FIGURE 5

NAIL POPS

5. REPAIR MEDIUM HOLES.

Bridge opening by criss-crossing two or three strips of self-adhering fiberglass mesh tape, fiberglass mesh repair patch, or conventional paper joint tape set in compound over opening. Apply joint compound over tape and around edges of hole with taping knife. Wipe away excess compound and let harden. Apply second coat of compound, sand and prime when dry.

ADVANTAGES: Relatively simple repair.

DISADVANTAGES: Requires some skill to cover tape and provide a smooth, uniform surface.

6. REPAIR LARGE CRACKS (1/8" TO 3/4").

Bridge opening with fiberglass mesh tape. Press and smooth joint compound into tape with taping knife. Apply second coat, sand and prime when dry.

ADVANTAGES: Relatively simple repair.

DISADVANTAGES: Requires some skill to provide smooth, uniform surface.

7. REPAIR TORN DRYWALL PANEL FACE PAPER.

Peel and remove loose face paper. Apply a skim coat of joint compound to damaged area with taping knife and feather for smooth finish. Let harden, apply second coat if necessary, sand and prime when dry.

ADVANTAGES: Relatively simple repair.

DISADVANTAGES: Will not be effective if gypsum under the removed paper is crumbly, which calls for replacement.

8. REPAIR LARGE HOLES OR WATER-DAMAGED AREAS WITH US GYPSUM REPAIR KIT.

Cut out damaged panel section using utility knife or keyhole saw along and between studs. Remove damaged sections and old fasteners. A repair method (Fig. 6) recommended by US Gypsum Company includes slipping a drywall repair clip onto edge of damaged section; screwing through the wall into each drywall repair clip, positioning screw about 3/4" from panel edge and centered between tabs. This will line up screw with perforations in the clip. Measure and cut new drywall panel section to fit damaged area. Screw through new drywall into each drywall repair clip, positioning screw opposite screw holding clip to existing wall, and about 3/4" from edge. Remove tabs from each drywall clip. Apply fiberglass or paper tape and two to three coats of joint compound as needed, feathering out from previous coats. Sand and prime when dry.

ADVANTAGES: Repair kit makes patching easier.

DISADVANTAGES: Requires some knowledge of drywall repair; large patches require replacement with drywall.

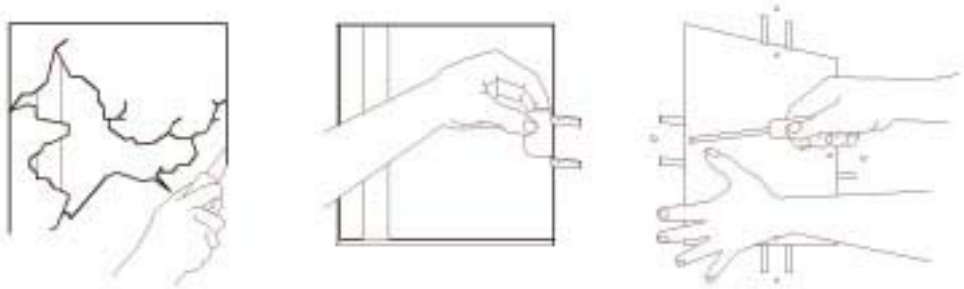

FIGURE 6

DRYWALL REPAIR CLIP TECHNIQUE

9. REPAIR LARGE SECTIONS OF DRYWALL.

Cut out damaged area with utility knife or keyhole saw along and between the studs. Remove damaged sections. Frame the opening with blocking to support new drywall. Cut new drywall panel section to fit damaged area leaving approximately 1/8" gap all around. Tape and apply two to three coats of drywall compound as needed, sand and prime when dry.

ADVANTAGES: Sections of drywall are relatively simple to replace.

DISADVANTAGES: Seamless taping and compounding requires skilled applicators.

10. LAMINATE WALLS AND CEILINGS WITH NEW DRYWALL.

When more than half of a plaster wall needs repair, the most cost-effective treatment may be laminating the existing surface with new drywall. For walls, 3/8" or even 1/4" thick material is usually sufficient. For ceilings 3/8" thick is usually adequate if fastened directly to joists, or furring strips running perpendicular to the joists, if the spacing does not exceed 16" o.c. For wider spacing of supports, 1/2" will deflect less between supports and may be required. Before laminating ceilings, the capability of the existing framing should be reviewed with an engineer to determine if it can support the additional load. Preferably, the gypsum board should be adhered to the existing surface with screws and adhesives, making sure that the screws are long enough to penetrate well into the structure, not just the lath.

ADVANTAGES: A cost-effective repair when there are extensive problems with existing wall and ceiling materials.

DISADVANTAGES: Adds significant weight to the existing surfaces which may not be able to be accommodated. Will cause detailing problems with the existing door and window trim. Requires expertise.

11. REPAIR CRACKED OR "ALLIGATORED" WALLS AND CEILINGS WITH FIBERGLASS MATS.

Historically, painters have used canvas applied over a wheat paste binder to cover moderately damaged, alligatored, or slightly uneven plaster surfaces prior to painting. A more recently developed ceiling material, NU-Wal[®], is a fiberglass mesh fabric roll that is applied to the damaged surface over an acrylic saturant (Fig. 7). After installation, an additional coat of saturant is applied to the wet mat. When the mat has dried, the wall is ready for painting. Other manufacturers, including Permaglas[™], provide self-adhesive rolls of fiberglass mesh that are designed to be skim-coated with plaster or drywall compound after application.

ADVANTAGES: Relatively easy to apply and coat.

DISADVANTAGES: Skim coat requires careful applicators to cover mat and smooth out; bumps must be sanded smooth prior to installation.



FIGURE 7

NU-WAL RESURFACING TECHNIQUE

12. APPLY NEW REPLACEMENT DRYWALL TO DAMAGED WALL SECTIONS

Replacement drywall products range from conventional paper-faced products available in regular and moisture- and fire-resistant configurations; abuse-resistant products, such as National Gypsum's Hi-Abuse[®] board with reinforced paper facing; impact-resistant board such as National Gypsum's Hi-Impact[®] board with a plastic Lexan facing on the interior (stud) side; and US Gypsum's FiberRock[®], a non paper-faced board made with recycled news print and wood particles. Gypsum board products that are reinforced with fiberglass mats on the fronts and backs of the board, such as Georgia-Pacific's Dens-Glass[®] products can be, but are generally not, used on interior walls, because the rough surfaces cannot be painted without a skim-coat of plaster, which is expensive and time-consuming to apply.

ADVANTAGES: Gypsum board comes in a variety of types and is the most used and cost-effective of all wall materials.

DISADVANTAGES: Requires proficient applicators and finishers as poorly installed, taped, and compounded drywall seriously distracts from appearance.

13. APPLY CORNER BEAD AND JOINT COMPOUND TO NEW DRYWALL.

A variety of new fast-setting joint compounds and corner bead systems have been developed recently that speed up the completion of projects by requiring less drywall compound than previous all-metal corner bead systems, resulting in savings of labor, material, and time. These systems include: paper-faced metal drywall beads and trim (US Gypsum); rigid vinyl drywall accessories (Trim-Tex, Inc.); and plastic and paper drywall (No-Coat[®] and Straight Flex[®]).

ADVANTAGES: Paper and plastic/metal taping systems lay flatter than all-metal systems, use less compound and therefore dry quicker, are easier and faster to apply, and less costly.

DISADVANTAGES: Not as strong as all-metal systems.

14. ALTERNATIVE TAPING TOOLS

Among the products on the market that combine the taping and joint compound application is the Homax Drywall Taping Tool, which accommodates five pounds of mesh and up to 500 feet of tape.

ADVANTAGES: Maintains a consistent amount of compound; applies tape smoothly to seams without folds or wrinkles.

DISADVANTAGES: Requires some skill; does not work on exterior and interior corners.

FURTHER READING

Drywall-Professional Techniques for Walls and Ceilings, Myron R. Ferguson, Newtown, CT: Taunton Press, 1996.

How to Install, Finish and Repair SHEETROCK Brand Gypsum Panels, US Gypsum Company, 1994.

Gypsum Construction Handbook, US Gypsum Company, 1995, www.usg.com.

Drywall Application, Canadian Mortgage and Housing Corporation, 1995.

Gypsum Construction Guide, National Gypsum Company, 1999, www.national-gypsum.com.

Fire Resistance Design Manual, 15th Edition, Gypsum Association, 1997.

PRODUCT INFORMATION

REPAIR PRODUCTS

Homax Products, Inc., P.O. Box 5643, Bellingham, WA 98225-7363; 800-729-9029; www.homaxproducts.com.

Nu-Wal[®] Restoration Systems (a fiberglass-acrylic system for interior and exterior walls) Specification Chemical Inc.[®], 824 Keeler Street, Boone, Iowa 50036, 800-247-3932.

Permaglas-Mesh[®] and Fibratape[®] (self-adhesive fiberglass tape, patches and rolls), Permaglas-Mesh, P.O. Box 220, Dover, Ohio 44622; 800-762-6694.

Sheetrock[®] All-In-One Drywall Repair Kit, US Gypsum Company, P.O. Box 806278, Chicago, IL 60606-4678; 800-874-4968; www.usg.com.

CORNER BEADS AND ACCESSORIES

Fibratape metal corner tape, Permaglas-Mesh, P.O. Box 220, Dover, Ohio 44622; 800-762-6694.

Sheetrock[®], paper-faced metal drywall bead and trim, US Gypsum Company, P.O. Box 806278, Chicago, IL 60680-4124; 800-874-4968; www.usg.com.

Trim-Tex, Inc. rigid vinyl drywall accessories, 3700 West Pratt Avenue, Lincolnwood, IL 60645; 847-679-3000.

No-Coat[®] pre-finished drywall corners, Drywall Systems International, P.O. Box 5937, Bend, OR 97708; 800-662-6281; www.no-coat.com.

StraitFlex[®] drywall corner tape, Conform International, Inc., 11632 Fairgrove Ind. Blvd., Maryland Heights, MO 63043; 314-692-8999.

5.2

PAINTS AND WALL COVERINGS

ESSENTIAL KNOWLEDGE

Paint and wallpaper are the two most common protective and attractive finishes applied to walls. Paint is either oil (alkyd) or water-based (latex, vinyl, or acrylic). Oil-based paint is less permeable, shows streaks less, is more durable, and usually takes longer to dry than water-based. Because it does not take abrasion as well as oil-based paint, water-based paint was historically less commonly used. However, today's water-based formulations, especially the all-acrylic paints, have improved significantly, and it is the most common type of paint used because it is easy to maintain, quick drying, and does not require thinning agents for clean-up. Although today's paints are lead-free and low in volatile organic compounds, it is important to consult applicable state and federal regulations on lead paint abatement, safety, and disposal when rehabilitating an older home. Wallpapers are used to provide a quick and easy finish. Historically, they were made of colored paper and applied to walls with adhesives. Today, these coverings commonly contain vinyl and are pre-pasted, applied with water and a sponge. Vinyl coverings are easy to maintain and are more durable than papers.

TECHNIQUES, MATERIALS, TOOLS

1. TREAT STAINS ON PAINTED WALLS.

The most effective cleaning agent for painted walls is a mild soap-and-water solution. However, painted surfaces can become stained and may require other cleaning techniques. Stains on painted walls are usually of two types: solvent or water soluble. Water-soluble stains can usually be removed by applying a solvent-thinned primer over them. Conversely, remove solvent-soluble stains by coating them with a water-thinned primer. Shellac is another effective product to use when trying to remove water-soluble stains. However, it is ineffective against most solvent-soluble stains.

If cleaning stains on painted walls with soap and water does not remove them, they will most likely require repainting. However, before repainting, be sure to prime stains with the appropriate solution. Mold or mildew growth will stain painted surfaces and must be eliminated before repainting, or they will reappear. A strong bleach-and-water solution applied over mold and mildew will usually work. Remove any dead spores by scrubbing with a strong detergent and flushing with clear water.

Water is commonly the source of stains on painted walls. If water stains are not primed correctly, they will always show through a new coat of paint. Water stains cannot be cleaned from painted surfaces but they can be prevented from bleeding by covering them with two or three coats of an oil-based primer.
ADVANTAGES: Cleaning stains is an alternative to repainting.
DISADVANTAGES: Removing stubborn stains may require repainting.

2. CLEAN PAPER AND VINYL WALL COVERING.

Some of the more common wall coverings are paper, vinyl-coated, vinyl acrylic, solid sheet vinyl, and laminated vinyl. Most of them are either “non-washable,” “washable,” or “scrubbable.” Test a small area in an inconspicuous location by wiping with a damp cloth. If the covering is paper and it does not change in color, it is most likely “washable.” If the wall covering is vinyl-based and does not change color when wiped with a damp cloth it is most likely “scrubbable.” Before cleaning the wall covering, use a vacuum to remove dust and loose dirt. Dusting walls with a cloth tied to a broom or mop will also remove dust particles.

Non-washable papers should be dusted frequently to avoid dirt or dust buildup. Putty-like commercial wallpaper cleaners are available and when used correctly they are effective. However, be sure to test them on an inconspicuous area first. Washable papers are commonly coated in plastic. Clean with a damp cloth and avoid wetting. After cleaning, wipe walls down with a clean dry cloth to remove any moisture. If the walls need a second cleaning allow them to dry completely before applying the damp cloth again. Scrubbable wall coverings are commonly made of vinyl or are vinyl-impregnated. These types of coverings can be cleaned with appropriate foam cleaners or detergents. Be sure to avoid abrasive cleaners. Rinse walls with a damp cloth after using any type of cleaner. Remove any moisture with a clean dry cloth.

A variety of dirt and stains can be removed by wiping with art gum or commercially available cleaners. Try a soap-and-water solution on washable or scrubbable coverings before using commercial cleaners. Use a warm iron over white paper towels to remove grease spots. Some spot removers applied to grease stains will turn them into a powder than can be brushed away. Use a soap-and-water solution to remove any remaining grease from washable or scrubbable wall coverings.

ADVANTAGES: Most wall coverings are easy to clean.

DISADVANTAGES: Non-washable papers are high maintenance and cannot be cleaned by common techniques.

3. REPAIR PAPER AND VINYL WALL COVERINGS.

Seams between strips of paper and vinyl wall coverings may separate from the wall and begin to peel back over time. Paper that isn't pasted correctly is usually the cause. There is commercially-available seam adhesive that does an effective job in repairing these minor problems. Use a small paint brush or sponge to coat the seam that has peeled away. Press back into position with a damp cloth or a seam roller. Horizontal tears can be repaired in the same way. Major rips or punctures must be cut out and repaired with a matching patch. With a sharp blade and a straight edge, remove a matching patch from inside a closet or behind a cabinet and cut out the tear (Fig. 9). Apply adhesive to the exposed wall and to the matching patch. If the paper is pre-pasted, soak the patch in water for about 30 seconds to activate the adhesive. Place into position and apply pressure with a damp cloth or seam roller. Tape the patch into position with masking tape to ensure proper adhesion. Blisters or air bubbles are usually caused by incorrect installation. If the blister or bubble is caused by something that has been trapped between the paper and the wall, it must be removed. Cut around the particle, remove it, repaste, and install the patch that has been removed. If the bubble or blister is just an air pocket, inject adhesive into this pocket with a commercially-available glue-injecting syringe. Flatten with a seam roller and use a damp cloth to remove any excess adhesive.

ADVANTAGES: Minor damage to wall coverings is easy to repair.

DISADVANTAGES: A matching patch of wallpaper may not be available.

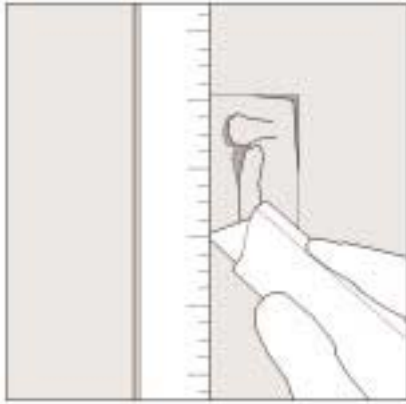

FIGURE 9

REMOVING RIPPED WALLPAPER

4. REMOVE PAPER AND VINYL WALL COVERINGS.

If paper and vinyl wall coverings have become too worn or outdated, they may require removal. It is best practice to remove old coverings before applying new ones. The removal process may be time consuming but is easy thanks to today's effective nondrip, nontoxic enzyme strippers. Wallpapers can be removed with hot water or commercial strippers. Because they are made of paper, they easily soak up water or strippers and can be peeled from the wall. Vinyl wall coverings are usually tear resistant and do not soak up water or strippers. The vinyl strips can usually be peeled away from the wall, but the adhesive backing will remain. Remove the adhesive backing by soaking with hot water or strippers. Several layers of paper, or paper and vinyl wall coverings that have been painted, are difficult and time consuming to remove because they are sealed and the adhesive cannot absorb water or strippers. Commercially-available scoring tools are most effective (Fig. 10). These tools can be run across the wall surfaces and create tiny punctures in the covering without damaging the wall. Strippers applied to the scored paper will penetrate the holes, loosening the adhesive from the wall.

ADVANTAGES: Commercial strippers make removal simple.

DISADVANTAGES: Removing some wall coverings, layers of coverings, and painted coverings is time consuming.



FIGURE 10

WALLPAPER SCORING TOOL

ESSENTIAL KNOWLEDGE

Wall trim and molding at floor level to about 6' above the floor can become abraded from furniture pushed up against it, touching, kicking, and cleaning. Chair rails were originally intended to protect plaster or wallpapered walls from damage caused by chairs pushed up against them. Older plaster trim may have been custom molded and woods custom milled. Today's moldings are usually hardwoods and are readily available at home centers. Minor abrasions to any type of molding can be easily repaired. Replacement may be required for severe damage.

TECHNIQUES, MATERIALS, TOOLS**1. REPAIR OR REPLACE DAMAGED TRIM.**

Minor damage to plaster trim can be repaired with patching compound. Sand smooth, prime, and repaint. Severely damaged or missing trim pieces can only be repaired by replacing with wood plastic or foam-based trim, spackling the seams, priming, and repainting. Trim to match old plaster moldings may not be available. However, there are many commercially available plastic or foam-based moldings that resemble original styles. Even wood trim that closely resembles the plaster can be used. Damaged wood trim can be repaired in the same fashion. Fill dents and cracks, sand smooth, and repaint. Prime all surfaces before applying a fresh coat of paint. Use non-toxic strippers to remove paint layers from moldings to restore them to their natural condition.

ADVANTAGES: Minor damage to moldings and trim are repaired quickly with spackle.

DISADVANTAGES: Major damage may require replacing.

2. PATCH DAMAGED TRIM.

Severely damaged trim may require a replacement patch. Cut out the piece of molding that needs replacing and try to locate matching wood or plastic trim to replace it. If matching molding cannot be located, one can be custom milled using the damaged piece as a template. Cut a matching piece to length and nail in place. Prime any unpainted surfaces before painting. When removing sections of molding, score the wall along the trim before it is removed (Fig. 11). This will prevent damage to the drywall during the removal process.

ADVANTAGES: Replacement patch pieces are easily disguised when painted to match the existing.

DISADVANTAGES: Matching profiles may not be available.

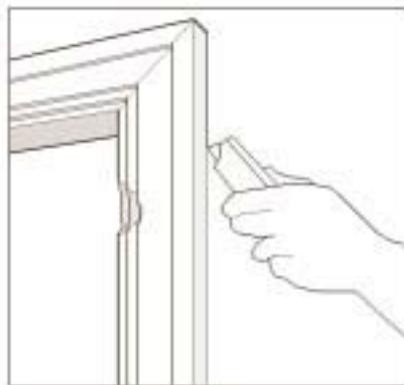

FIGURE 11

SCORE WALL TO REMOVE TRIM

FURTHER READING

Troubleshooting Guide to Residential Construction, Editors of the *Journal of Light Construction*, Richmond, VT, 1997.

Hess's Paint Film Defects: Their Causes and Cure, H.R. Hamburg, and W.M. Morgans, Chapman and Hall, 1979.

Paint Handbook, Guy E. Weismantel, New York: McGraw-Hill, 1981.

Wallpaper In America, New York: Barra Foundation/Cooper Hewitt Museum, 1980.

"Rx for Latex Paint Problems," *Journal of Light Construction*, January, 1997.

House Painting Inside and Out, Mark Dixon, Newtown, CT: Taunton Press, 1997.

"Stripping Wallpaper," *Old-House Journal*, December, 1997.

Respectful Rehabilitation: Walls and Molding, Natalie Shivers, Washington, DC: The Preservation Press, 1990.

Caring for Your Historic House, Washington, DC: Heritage Preservation and National Park Service, 1998.

PRODUCT INFORMATION

Duron Paints & Wallcoverings, 10406 Tucker St., Beltsville, MD 20705; 800-723-8766; www.duron.com.

Fuller O'Brien, 925 Euclid Ave., Cleveland, OH 44115; 888-265-6753; www.fullerpaint.com.

Martin Senour Paints, Cleveland, OH; 800-MSP-5270.

Benjamin Moore & Co., 51 Chestnut Ridge Rd., Montvale, NJ 07645; 201-573-9600; www.benjamin-moore.com.

The Sherman-Williams Company, Cleveland, OH 44115; 800-321-8194.

MDC Wallcoverings, 1200 Arthur Ave., Chicago, IL 60007; 847-437-4000, www.mdcwallcoverings.com.

Maya Romanoff, 1730 West Greenleaf, Chicago, IL 60626; 312-465-6909.

Fypon Molded Millwork, 22 West Pennsylvania Ave., Stewartstown, PA 17363; 800-537-5349, www.fypon.com.

Arvid's Woods, 2500 Hewitt Ave., Everett, WA 98201; 800-627-8437.

Focal Point, PO Box 93327, Atlanta, GA 30377-0327; www.focalpointap.com.

6

STAIRS

6.1

REPAIRING TREADS AND RISERS

ESSENTIAL KNOWLEDGE

Stairs can have either open or closed risers. When staircases are constructed of both risers and treads, they are called closed-riser stairs. When staircases are constructed without risers, they are referred to as open-riser stairs, or ladder stairs. In all cases, treads are the essential element that allows one to negotiate a stairway, moving vertically from one floor to the next.

Over time, the natural course of a home's settlement, wood shrinkage, and the constant use of stairs begins to separate treads from the supporting carriage or risers, causing squeaks. Squeaks may also be caused by a riser that rubs against a tread or the carriage. "Squeaky" treads and risers are the most common complaints from owners or occupants of homes with older stairs.

TECHNIQUES, MATERIALS, TOOLS

1. USE GRAPHITE POWDER TO FIX SQUEAKY TREADS AND RISERS.

In order to stop treads or risers from squeaking, they must first be located. Walk up or down the stairs to locate where the squeak occurs. A quick fix to silence squeaky treads or risers can be achieved by blowing powdered graphite into the joint between the tread and the riser. The graphite lubricates the joint and eliminates squeaks by reducing the friction that results when wood members slide against each other.

ADVANTAGES: An inexpensive and quick solution to silencing squeaks.

DISADVANTAGES: Graphite powder is a temporary fix because it will wear away eventually. As a result, the squeaks will reoccur.

2. REFASTEN TREAD FROM ABOVE.

More permanent remedies for squeaks include nailing the tread down with angled nails or trim head screws, or wedging the tread tight. If squeaks occur near the center of the tread, angle finishing nails into riser below. If the squeak occurs at the ends of the tread, angle finishing nails into the carriage. Whenever possible, nail the tread into the carriage or stringer. For example, if a staircase has three carriages, one on each end and one in the center, and the squeak occurs near the center of the tread when it is stepped on, it is best to angle finishing nails into the center carriage. Because staircases in older homes are usually constructed of hardwood, pilot holes must be drilled before nailing or screwing to prevent splitting. Countersink nails and screws and fill with a wood filler.

ADVANTAGES: Nailing or screwing treads in place is a permanent solution to silencing squeaks. Sometimes access to the underside of a staircase may not be an option. As a result, working from above is the most convenient and least time consuming method of repair.

DISADVANTAGES: Repairing squeaky treads or risers from above may not solve the problem. If this method is not successful one must consider working from below. However, working from below can present a challenge because the stair structure may be hidden behind a finished surface or may be out of reach because it may connect levels of the building which are above the first floor.

3. REFASTEN TREAD FROM BELOW.

If access to the underside of stairs is possible, wood blocks can be glued at the joint between the riser and tread. If old blocks are already present they may be removed, re-glued, and re-fastened. Metal angle-

brackets can also be installed at this joint to secure the treads and risers (Fig. 1). If the squeaks are caused by a tread which has been loosened significantly from the carriage or has become too warped, it can be re-fastened to the carriage from below using screws instead of finishing nails. Lubricate screws with paraffin wax if they are used to fasten oak treads. The wax will allow the screw to pierce hardwood more easily. Countersink the screws and fill with a wood filler.

ADVANTAGES: Wood blocks or metal angle-brackets fastened to the underside of stairs are strong supports that are hidden from view.

DISADVANTAGES: If the underside of stairs is finished, the surface must be removed to reveal the stair structure. The underside of stairs may be out of reach and may require complicated equipment to gain access.

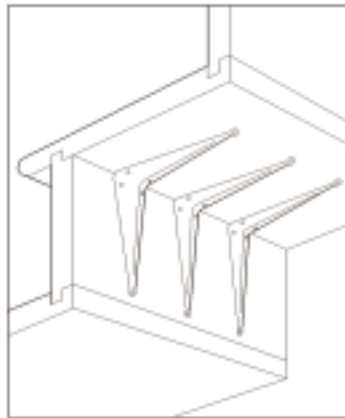

FIGURE 1

METAL ANGLE BRACKETS

4. USE WOOD WEDGES TO FIX SQUEAKY STAIRS.

Instead of using nails or screws, inserting wooden wedges into the joint between the riser and the tread from above may be a simple and quick fix to eliminate squeaks. Many older staircases have moldings that run under nosings and at the back of treads where they join the risers. This molding can be removed and wedges can be inserted. Once the molding is removed, insert a knife or similar tool into the joint between the tread and riser. This will reveal the type of joining system used in the stair's construction. The joints used to fasten treads to risers are either butt, rabbeted, or tongue-and-groove. Coat hardwood wedges with glue and hammer them into the joint as far as possible. Once the wedge is inserted, cut off the visible end and replace the molding.

ADVANTAGES: Using wood wedges to secure treads and risers is a quick and inexpensive method of reinforcement which is hidden from view. This method eliminates the need for nails or screws.

DISADVANTAGES: Damage to moldings may occur if they must be removed from under nosings or at the back of treads where they join the risers.

FURTHER READING

Floors and Stairways, By the Editors of Time-Life Books, Alexandria, VA, 1995.

Basic Stairbuilding, Scott Schuttner, Newtown, CT: Taunton Press, Inc., 1990.

"Finding and Fixing Stair Problems," Edward R. Lipinski, *New York Times*, November 1998.

Home Improvement Home Repair, Richard V. Nunn, Creative Homeowner Press, 1980.

"Trouble-Free Stairs," Rob Dale Gilbert, *Journal of Light Construction*, April 1997.

ESSENTIAL KNOWLEDGE

Treads are the one stair component that get the most wear. As a result, they may become unevenly worn, crack, split, or even become so scratched that replacing them is the best option. Conversely, risers are probably the least likely to become worn; however, over time they may become subject to cracks or dents and need replacing as well. Treads and risers can be replaced with readily available stock treads and custom-cut hardwoods. Stock treads are available with integral factory-milled nosings. Whether the staircase is open on one or both sides, or located between walls, replacing treads and risers is a relatively simple procedure.

TECHNIQUES, MATERIALS, TOOLS**1. REPLACE TREADS AND RISERS.**

If a rehab project involves replacing all treads and risers, perhaps the most obvious recommendation is to begin at the bottom of the staircase. Before starting on the treads and risers, all of the balusters must be removed (See Section 6.4: Damaged or Broken Balusters). If the project requires the replacement of isolated treads or risers the same method applies; however, only remove those balusters that attach to the damaged tread. Begin by prying the first riser and tread from the carriage or stringer. Hammering a pry bar into the joint between the first riser and the first tread will help lift the tread. If nails are exposed and prevent the tread or riser from being removed, cut them using a utility saw.

If the tread or riser cannot be lifted, try drilling holes into the tread in two places to allow access for a saw (Fig. 2). Cut into the tread from the back of the riser below to the face of the riser at the back of the tread. Chisel off the nosing attached to the tread. Begin removing the tread by prying the cut sections of the tread from the carriage using a pry bar and a hammer. After removing the first three or four treads and risers, install the new ones, being careful not to close the staircase in order to allow access for removing the rest of the treads and risers. Cut the risers so that their ends are flush with the face of the carriage. If using a stock tread with an integral nosing, cut off the side nosing that protrudes over the carriage. Beginning at the right angle at the front of the tread in the corner that meets the carriage, and make a 45° cut into the tread for the depth of the nosing. Then saw off the rest of the integral nosing along the entire side of the tread (Fig. 3).

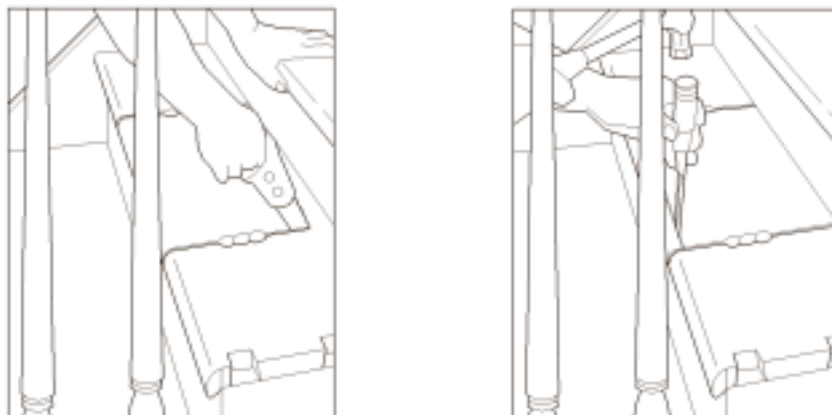

FIGURE 2

CUTTING AND CHISELING TO REMOVE TREAD

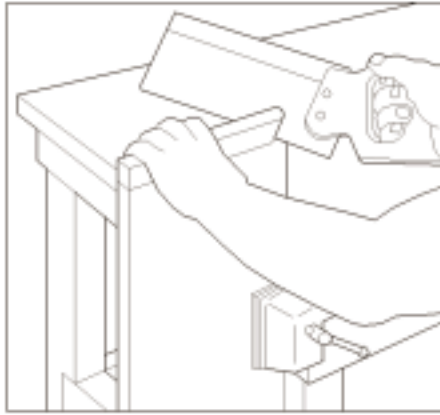

FIGURE 3

REMOVE SIDE NOSING ON TREAD

Install the newly-cut tread so that the ends are flush with the face of the end carriages and it abuts the riser above and below. Fasten to the riser below using nails or screws and fasten to the back riser using pre-drilled pilot holes and driving nails or screws on an angle from the top of the tread into the back riser. If stairs can be accessed from below, fasten risers to treads from under the stair using nails or screws. If the treads and balusters are dovetail jointed, hold the balusters against the treads and mark where the joint must be cut. Remove the tread and cut the joint which will receive the baluster. Install and fasten the treads to the risers and the carriage. Insert the balusters in place and fasten the return nosing.

ADVANTAGES: Replacing treads and risers is a permanent fix for those that have become unevenly worn or damaged. Because damaged treads may present safety concerns, replacing them may reduce hazardous conditions that risk safety.

DISADVANTAGES: Replacing treads and risers along an entire stair run may be costly and time consuming. Removing the balusters without damaging them and reinstalling them intact is not easy. If damage to balusters occur, they may require replacing.

FURTHER READING

Floors and Stairways, By the Editors of Time-Life Books, Alexandria, VA, 1995.

Home Improvement Home Repair, Richard V. Nunn, Creative Homeowner Press, 1980.

"Trimming Out Stairs," Jed Dixon, *Journal of Light Construction*, March 1999.

PRODUCT INFORMATION

REPLACEMENT TREADS AND RISERS

Carlisle Restoration Lumber, 1676 Route 9, Stoddard, NH 03464; 800-595-9663.

Vintage Lumber, 1 Council D., P.O. Box 104, Woodsboro, MD 21798; 800-499-7859.

ESSENTIAL KNOWLEDGE

Over time, stair carriages may begin to sag or bow. Sagging carriages may loosen the connection between risers and treads, causing riser heights to vary along the stair run and creating a potentially hazardous condition. If this is the case, the staircase may need to be replaced entirely. However, if the sagging carriage has not jeopardized the safety of the staircase, it may be reinforced to prevent further sag.

TECHNIQUES, MATERIALS, AND TOOLS**REINFORCE A SAGGING CARRIAGE.**

More often than not, the underside of the sagging stair will have a finished surface. This surface must be removed to expose the stair structure. Once the structure can be accessed, it can be reinforced to prevent further sag by screwing metal angle brackets or wood blocks through the carriage and into the supporting structure. For added support, one or more new carriages can be installed. For a staircase that is open on one side, constructing a knee wall below the stair may be a practical reinforcement solution. Because a sagging carriage may be fixed in a number of ways, a qualified structural engineer will be able to recommend the best option for repair.

ADVANTAGES: Reinforcing sagging carriages from below the stair structure is usually a simple and permanent process.

DISADVANTAGES: Reinforcing a sagging carriage may require finish surfaces under stairs to be removed to expose the stair structure. If the underside of stairs is not reachable, accessing the sagging carriage can be challenging.

FURTHER READING

Floors and Stairways, By the Editors of Time-Life Books, Alexandria, VA, 1995.

"*Trouble-Free Stairs*," Rob Dale Gilbert, *Journal of Light Construction*, April 1997.

PRODUCT INFORMATION

Building Components Manufacturing Inc., P.O. Box 9328, Minneapolis, MN 55440-9328; 800-475-9304.

ESSENTIAL KNOWLEDGE

Balusters are the individual vertical elements that attach the railing to the staircase. Railings are attached to a newel post usually found at the top or bottom of the run. Balusters may not be present if railings are attached directly to a wall, as is the case with a closed stair encased between walls, or a stair that is open on only one side. Over time, balusters can become loose or broken. It is important to remedy this situation because the balusters provide the structural support to the handrail. Repairing a loose balustrade can be a simple process. However, replacing balusters may be more involved, depending on the way they are connected to the handrail and stair. There are generally three different types of connections: filleted, doweled, and dovetailed.

A filleted baluster is usually square-topped and fits into a groove at the underside of the railing. Fillets, or small blocks of wood, are secured into this groove between balusters which holds them in place. These types of balusters may also be inserted into the groove of a lower rail which is attached to the stringer. Balusters can also be doweled at the bottom or the top, or doweled at the top and dovetail jointed to the tread at its base. The exact profile of balusters in need of replacement may not be available. Using the broken baluster as a template, a skilled mill worker can turn an exact replica.

TECHNIQUES, MATERIALS, TOOLS

1. STRENGTHEN EXISTING BALUSTERS.

Loose balusters can be secured by re-attaching them to the railing with nails or screws. Pilot holes can be bored on an angle at the top of the balustrade and into the railing. Drive the nails or screws into the pilot holes through the baluster and into the railing. The same technique may be used to fasten the bottom of the baluster to the stair.

ADVANTAGES: Because this type of repair requires fastening from the underside of the railing, it usually goes unnoticed if nails and screws are countersunk and filled.

DISADVANTAGES: Loose balusters may be caused by damage to the baluster itself. If this is the case, securing the baluster to the rail or to the tread below will not solve the problem. If damage to the baluster occurs, it will have to be repaired in place or removed and replaced.

2. REPLACE FILLETED BALUSTERS.

To remove a filleted baluster, chisel out the fillets at the railing and at the base. The baluster may be easily hammered out and removed. Be careful to remove any old glue from the grooves into which the new baluster will be inserted. The proper angle for the new balusters can be obtained by holding the old one at its side and marking the angle on the new one. Insert the new balusters into the grooves at the rail and base and fasten by toe-nailing. Measure and cut new fillets using the old baluster to determine the correct angle. Coat with glue and insert into the grooves between balusters.

ADVANTAGES: Because the actual joint between the balusters and the rail or base is hidden by the fillets, slight inaccuracies in cutting or fastening will go unnoticed. Removing the return nosing on treads is not required when installing filleted balusters.

DISADVANTAGES: Replacing filleted balusters along an entire stair run may be time consuming because it requires measuring and cutting blocks of wood into many small lengths.

3. REPLACE DOWELED BALUSTERS.

A broken doweled baluster may be removed by sawing it in half and prying it loose from the glue joint at the tread and from the underside of the railing (Fig. 4). Breaking the glue joint is not always possible. If this is the case, saw the baluster flush with the tread or underside of the railing and use a drill with a bit that is the same size as the dowel to bore a new dowel hole. Coat the dowels on the new baluster and the dowel holes in the railing and tread with glue. Angle the baluster and insert the upper doweled end into the hole in the railing first. Lifting the railing, drag the bottom end of the baluster across the tread and insert it into the hole. If the railing will not lift, trim the dowel ends to shorten the baluster.

ADVANTAGES: Doweled balusters are easy to remove and do not require the time consuming process of prying them from the rail or base or measuring and cutting fillets. Boring a new dowel hole is also a simple procedure. Removing the return nosing on treads is not required when installing a doweled baluster. Nails or screws are not required for fastening.

DISADVANTAGES: Once the new doweled baluster is inserted into the rail, it may not be easy to lift the rail to insert the base of the baluster. As a result, if precautions aren't taken to protect the tread, dragging the baluster along the tread may damage its surface.

4. REPLACE DOVETAILED BALUSTERS.

In order to remove balusters that are fastened to the tread with a dovetail joint, first remove the cap molding or return nosing that attaches to the side of the tread and covers the dovetail joint. This nosing can be

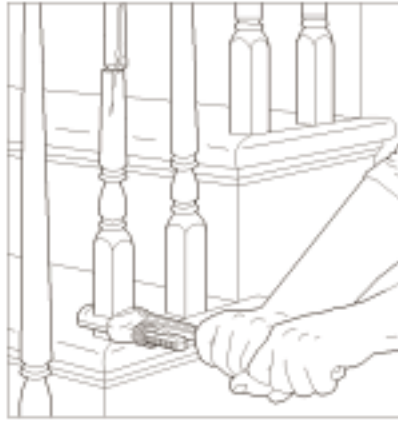

FIGURE 4

BREAK GLUE JOINT WITH WRENCH

pried away from the tread using a pry bar. The joint between the tread and the nosing may need to be cracked before it can be pried away. The baluster may be hammered out once the dovetail is revealed. To replace a dovetail baluster, insert its top into the underside of the railing first and then insert the dovetail into the tread. Drill pilot holes through the dovetail and into the tread and secure with nails or screws. Replace and secure the return nosing, being careful to countersink any nails or screws and fill with putty.

ADVANTAGES: A dovetail joint is the strongest type of joint and provides the most stability. As a result, a dovetail baluster is less likely than balusters connected to rails or treads by other types of joints to become loose or need replacing.

DISADVANTAGES: Removing dovetailed balusters from the tread is a time consuming process because the joint may be difficult to separate. The return nosings on treads must be removed before dovetailed balusters can be installed and nails or screws are required for fastening.

FURTHER READING

Floors and Stairways, By the Editors of Time-Life Books, Alexandria, VA, 1995.

“Foolproof Handrail Layout,” Don Zepp, *Journal of Light Construction*, Volume 15, Number 1, October 1996.

“Sturdy Site-Built Stairs,” David Frane, *Journal of Light Construction*, Volume 14, Number 2, November 1995.

Home Improvement Home Repair, Richard V. Nunn, Creative Homeowner Press, 1980.

“Stiffening Stairway Railings,” Gordon Tully, *Journal of Light Construction*, Volume 8, Number 10, July 1990.

“Trimming Out Stairs,” Jed Dixon, *Journal of Light Construction*, March 1999.

PRODUCT INFORMATION

Mylan Stairs, Inc., 650 Washington St., Peekskill, NY 10566, 800-431-2155.

Stairways, Inc., 4166 Pinemont, Houston, TX, 77018, 800-231-0793.

Spaulding Craft Inc., 1053 Harbor Lake Dr., Safety Harbor, Florida 34695, 727-725-2057.

L.J. Smith Stair Systems, 35280 Scio-Bowerston Rd., Bowerston, OH 44695, 614-269-2221.

ESSENTIAL KNOWLEDGE

If rehabilitating an existing staircase is not possible, or if constructing a site-built staircase to replace an older one is too costly, factory-built staircases are an economical solution to stair replacement. There is a variety of styles for both closed- and open-riser stairs manufactured in a variety of materials and finishes to fit almost any taste. Whether installing a prefabricated stair housed between walls or open on one or both sides, the technique is the same.

If a prefabricated stair is to be installed between walls, handrails must simply be fastened to one or both walls, depending on code requirements. If a stair is open on one or both sides, then a balustrade must be installed. This is the most complex and time consuming part of installing a prefabricated stair. If you are installing a prefabricated stair and have removed the preexisting stair structure, chances are that access to the stair from below is possible. However, if installing a stair housed between walls and access from below is not available, remove the wall's surface material to allow easy access.

When replacing an existing stair with a prefabricated stair, be cautious with the demolition work. Older stairs are sometimes part of the home's structure and may be difficult to remove. Before ordering the stair, be sure to check with the local building department for code requirements.

TECHNIQUES, MATERIALS, TOOLS**1. INSTALL A PREFABRICATED STAIR.**

Once the prefabricated stair is delivered, it is ready for installation. First drill pilot holes in the top riser so that it can be fastened to the header in the stair opening. With someone standing at the opening above, position the stair so that the top riser rests against the header in the stair opening and is flush with the subfloor. Shim under the stair which rests on the floor below to ensure that the treads are exactly horizontal. Secure the top riser to the header using finishing screws. With the stair in position, locate studs on the walls to which stringers will be attached. Fasten the top plate to the underside of the staircase about 1 1/2" in from the open end. Hammer nails through the top plate up through the risers. Fasten a bottom plate to the floor below and toe-nail studs in place. Prefabricated stairs can be ordered with a balustrade that is precut and ready for installation after the stair is secured in position. Since this may be the most difficult and time consuming part of the prefabricated stair installation, it is important to carefully follow the manufacturer's installation recommendations.

ADVANTAGES: An economical solution to replacing or adding a stairway. Many styles available from many different prefabricated stair manufacturers. Manufacturers offer step-by-step instructions to ensure that the stair is assembled correctly.

DISADVANTAGES: Custom options are usually not available. Make sure that measurements are accurate to ensure that the stair fits properly.

2. USE A PREFABRICATED STRINGER FOR STAIR CONSTRUCTION.

An innovative prefabricated stair system called the Easy Riser provides an alternative to traditional notched-stringer stair construction. The Easy Riser stair is a two-stringer, engineered wood system that uses prefabricated individual components which, when fastened to a 2x6 or 2x8, create the effect of a notched stringer onto which the risers and treads are fastened (Fig. 5).

ADVANTAGES: Significantly reduces the time and labor involved in constructing traditional notched-stringer stairs

DISADVANTAGES: Cost for individual tread/riser components may be more than labor/time savings.

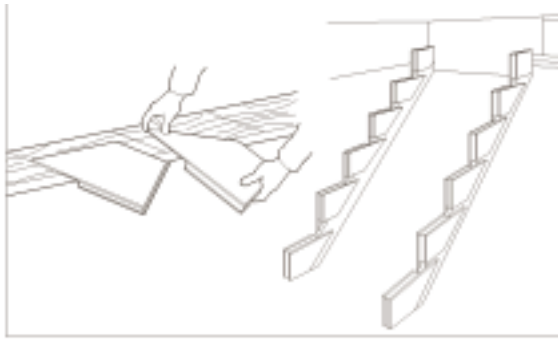

FIGURE 5

EASY RISER SYSTEM

FURTHER READING

Floors and Stairways, By the Editors of Time-Life Books, Alexandria, VA, 1995.

Basic Stairbuilding, Scott Schuttner, Newtown, CT: Taunton Press, 1990.

“Building Stairs with Stock Parts,” Bill McLearn, *Journal of Light Construction*, Volume 9, Number 5, February 1991.

“New Curve to Stairway Design,” Charles Wardell, *Journal of Light Construction*, Volume 12, Number 5, February 1994.

PRODUCT INFORMATION

Mylen Stairs, Inc., 650 Washington St., Peekskill, NY 10566; 800-431-2155.

Stairways, Inc., 4166 Pinemont, Houston, TX, 77018; 800-231-0793.

Spaulding Craft Inc., 1053 Harbor Lake Dr., Safety Harbor, Florida 34695; 727-725-2057.

Coffman Stairs, 1000 Industrial Rd., Marion, VA 24354; 540-783-7251.

L.J. Smith Stair Systems, 35280 Scio-Bowerston Rd., Bowerston, OH 44695; 614-269-2221.

Easy Riser, Building Components Manufacturing Inc., P.O. Box 9328, Minneapolis, MN 55440-9328; 800-475-9304.

Designed Stairs, 1480 East Sixth St., Sandwich, Illinois 60548; 877-478-2477.

6.6

ATTIC LADDERS

ESSENTIAL KNOWLEDGE

Providing access to attics is a practical solution to the lack of available storage space common to many homes. However, accessing the attic may not have been part of the original design of the home. As a result, floor space may not be available to allow for the construction of a new staircase to the attic. Installing an attic ladder, or disappearing stair, may be a simple and practical way to gain access to the attic. Factory-built attic ladders are available in a number of standard sizes. Because different attic ladders have different clearance and headroom requirements it is important to check these measurements. Before making any cuts in the ceiling or attic floor be sure to install shoring or supports. This is especially important if

the opening will be cut so that the long side will run perpendicular to the joists. A stair opening of this type will require approximately six joists to be cut. To minimize the number of joists to be cut, locate the stair opening so that the long side runs parallel to the ceiling joists.

TECHNIQUES, MATERIALS, TOOLS

1. INSTALL AN ATTIC LADDER.

The factory-built attic stair (Fig. 6) will require that the hole to receive the stair be cut to specific dimensions. Mark those dimensions on the ceiling and drill holes into the ceiling at the four corners. Snap chalk lines that connect these drill holes and then snap chalk lines that extend 3" outside the perimeter of the original markings. Saw the attic floorboards along the perimeter of the outside chalk lines. Remove the attic floorboards and subfloor. From below, remove the ceiling section which covers the opening in the same way the attic floor was removed. The exposed joists should be sawed so that they are flush with the opening. Install trimmer joists along the long sides of the opening. Using joist hangers, install double headers against the cut ends of the tail joists. Once the opening is cut according to the manufacturer's dimensions, the attic stair is ready to be installed. Carefully follow the manufacturer's recommendations for installation. If possible, mount insulation material on top side of access hatch so ceiling insulation performance is not degraded.

ADVANTAGES: A simple solution that provides access to attics and can be hidden from view when not in use. Very economical, arrives at the job site fully assembled, requires minimal adjustments, can usually be installed in a few hours.

DISADVANTAGES: Requires an opening to be cut in the ceiling for its installation. To avoid cutting too many joists and to ensure that the structural integrity of the ceiling is not compromised, openings should be located so that the long side runs parallel to the joists. If this cannot be accomplished, a structural engineer should be consulted for advise on proper reinforcement.



FIGURE 6

PREFABRICATED ATTIC LADDER

FURTHER READING

Floors and Stairways, By the Editors of Time-Life Books, Alexandria, VA, 1995.

Basic Stairbuilding, Scott Schuttner, Newtown, CT: Taunton Press, 1990.

PRODUCT INFORMATION

DJ Wholesale Building Material Distributors, Inc., P.O. Box 825, Putney Rd., Brattleboro, VT 05301.

Auciello Iron Works, Inc., 560 Main St., Hudson, MA 01749; 978-568-8382.

Precision Ladders, LLC, 5727 Superior Dr., Morristown, TN 37814; 800-225-7814.

APPENDIX

PROFESSIONAL ASSOCIATIONS AND RESEARCH CENTERS

ADHESIVE AND SEALANT COUNCIL
1627 K Street, NW
Suite 1000
Washington, DC 20006-1707
202-452-1500
www.ascouncil.org

AMERICAN FIBERBOARD ASSOCIATION
AMERICAN HARDBOARD ASSOCIATION
1210 W. Northwest Highway
Palatine, IL 60067
847-934-8800

AMERICAN FOREST & PAPER
ASSOCIATION/AMERICAN WOOD COUNCIL
111 19th Street NW, Suite 800
Washington, DC 20036
202-463-2700
www.awc.org

APA—THE ENGINEERED WOOD ASSOCIATION
P.O. Box 11700
Tacoma, WA 98411-0700
253-565-6600
www.apawood.org

AMERICAN NATIONAL STANDARDS INSTITUTE
11 West 42nd Street, 13th Floor
New York, NY 10036
212-642-4900
www.ansi.org

AMERICAN SOCIETY FOR TESTING AND
MATERIALS
100 Barr Harbor Drive
West Conshohocken, PA 19428
610-832-9500
www.astm.org

AMERICAN SOCIETY OF CIVIL ENGINEERS
1801 Alexander Bell Drive
Reston, VA 20191-4400
800-548-2723
www.asce.org

AMERICAN WOOD PRESERVERS INSTITUTE
2750 Prosperity Avenue
Suite 550
Fairfax, VA 22031800-356-AWPI
www.awpi.org

ARCHITECTURAL WOODWORK INSTITUTE
1952 Isaac Newton Square
Reston, VA 22090
703-222-1100

ASSOCIATION OF SPECIALISTS IN CLEANING
AND RESTORATION
10830 Annapolis Junction Road, Suite 312
Annapolis Junction, MD 20701-1120
301-604-4411

ASSOCIATION OF THE WALL AND CEILING
INDUSTRIES
1600 Cameron Street
Alexandria, VA 22314
703-684-2924

CANADA MORTGAGE AND HOUSING
CORPORATION
Housing Information Center
700 Montreal Road
Ottawa, ON, Canada K1A 0P7
613-748-2367
www.cmhc-schl.gc.ca

CANADIAN CONSTRUCTION MATERIALS
CENTRE
Institute for Research in Construction
National Research Council
Montreal Road, Bldg. M-24
Ottawa, ON, Canada K1A 0R6
613-993-6189
www.nrc.ca/ccmc

CARPET AND RUG INSTITUTE
P.O. Box 2048
Dalton, GA 30722
800-882-8846
www.carpet-rug.com

CERAMIC TILE INSTITUTE OF AMERICA
12061 Jefferson Blvd.
Culver City, CA 90230-6219
310-574-7800

CONSTRUCTION SPECIFICATIONS INSTITUTE
99 Canal Center Plaza, Suite 300
Alexandria, VA 22314
800-689-2900
www.csinet.org

COUNCIL OF AMERICAN BUILDING OFFICIALS
5203 Leesburg Pike, Suite 708
Falls Church, VA 22041
703-931-4533
www.cabo.org

DRYWALL, LATH AND PLASTER ASSOCIATION
3127 Los Feliz Blvd.
Los Angeles, CA 90039
323-660-4411

ENGINEERED WOOD ASSOCIATION
7011 S. 19th Street
P.O. Box 11700
Tacoma, WA 98411
253-565-6600
www.apawood.org

THE ENTERPRISE FOUNDATION
10227 Wincopin Circle, Suite 500
Columbia, MD 21044
800-624-4298
www.enterprisefoundation.org

FOREST PRODUCTS LABORATORY
US Dept. of Agriculture
One Gifford Pinchot Drive
Madison, WI 53705-2398
608-231-9200
www.fpl.fs.fed.us/

GYPSUM ASSOCIATION
810 1st Street, NE, Suite 510
Washington, DC 20002
202-289-5440
www.gypsum.org

HARDWOOD PLYWOOD & VENEER
ASSOCIATION
PO Box 2789
Reston, VA 20195-0789
703-435-2900
www.hpva.org

INSTITUTE OF INSPECTION, CLEANING AND
RESTORATION CERTIFICATION
2715 E. Mill Plain Blvd.
Vancouver, WA 98661
360-693-5675
www.iicrc.org

MAPLE FLOORING MANUFACTURERS
ASSOCIATION
60 Revere Drive, Suite 500
Northbrook, IL 60062
847-480-9138
www.maplefloor.org

NAHB REMODELERS COUNCIL
1201 15th Street, NW
Washington, DC 20005
202-822-0212

NATIONAL ASSOCIATION OF THE
REMODELING INDUSTRY
3800 N. Fairfax Drive, Suite 2
Arlington, VA 22203-1627
703-276-7600
www.nari.org/home.html

NATIONAL INSTITUTE OF BUILDING SCIENCES
1090 Vermont Ave., NW,
Suite 700
Washington, DC 20005
202-289-7800
www.nibs.org

NATIONAL OAK FLOORING MANUFACTURERS
ASSOC.
P. O. Box 3009
Memphis, TN 38173-0009
901-526-5016

**NATIONAL PAINT AND COATINGS
ASSOCIATION**
1500 Rhode Island Avenue, NW
Washington, DC 20005
202-462-6272
www.paint.org

NATIONAL WOOD FLOORING ASSOCIATION
16388 Westwoods Business Park
Ellisville, MO 63021
800-422-4556
www.woodfloors.org

NATIONAL TECHNICAL INFORMATION SERVICE
US Department of Commerce
5285 Port Royal Road
Springfield, VA 22161
800-553-6847
www.ntis.gov

NATIONAL WOOD FLOORING ASSOCIATION
16388 Westwoods Business Park
Ellisville, MO 63021
800-422-4556
www.woodfloor.org

**PAINTING AND DECORATING CONTRACTORS
OF AMERICA**
3913 Old Lee Highway, Suite 33B
Fairfax, VA 22030
800-332-7322
www.pdca.com

RESILIENT FLOOR COVERING INSTITUTE
401 East Jefferson St.
Suite 102
Rockville, MD 20850
301-340-8580

**SEALANT, WATERPROOFING, AND
RESTORATION INSTITUTE**
2841 Main
Kansas City, MO 64108
816-472-7974
www.swrionline.org

**SOCIETY FOR THE PRESERVATION OF NEW
ENGLAND ANTIQUITIES**
Harrison Gray Otis House
141 Cambridge Street
Boston, MA 02114
617-227-3956

SOUTHERN FOREST PRODUCTS ASSOCIATION
PO Box 641700
Kenner, LA 70064-1700
504-443-4464
www.sfpa.org

SUSTAINABLE BUILDINGS INDUSTRY COUNCIL
1331 H Street, NW, Suite 1000
Washington, DC 20005
www.sbicouncil.org

TILE COUNCIL OF AMERICA, INC.
100 Clemson Research Blvd.
Anderson, SC 29625
864-646-8453
www.tileusa.com

TRUSS PLATE INSTITUTE
583 D'Onofrio Drive, Suite 200
Madison, WI 53719
608-833-5900

WESTERN WOOD PRODUCTS ASSOCIATION
522 SW 5th Avenue
Portland, OR 97204-2122
503-224-3930
www.wwpa.org

WOOD TRUSS COUNCIL OF AMERICA
One WTCA Center
6425 Normandy Lane
Madison, WI 53719-1133
608-274-4849
www.woodtruss.com

THE REHAB GUIDE

VOLUME ONE: FOUNDATIONS

VOLUME TWO: EXTERIOR WALLS

VOLUME THREE: ROOFS

VOLUME FOUR: WINDOWS AND DOORS

VOLUME FIVE: PARTITIONS, CEILINGS, FLOORS AND STAIRS

VOLUME SIX: KITCHENS & BATHS

VOLUME SEVEN: ELECTRICAL/ELECTRONICS

VOLUME EIGHT: HVAC/PLUMBING

VOLUME NINE: SITE WORK

U.S. Department of Housing and Urban Development
Washington, DC 20410-6000

Official Business
Penalty for Private Use, \$300

November 1999
HUD-DU100C000005956

