

VOL 6

D/W

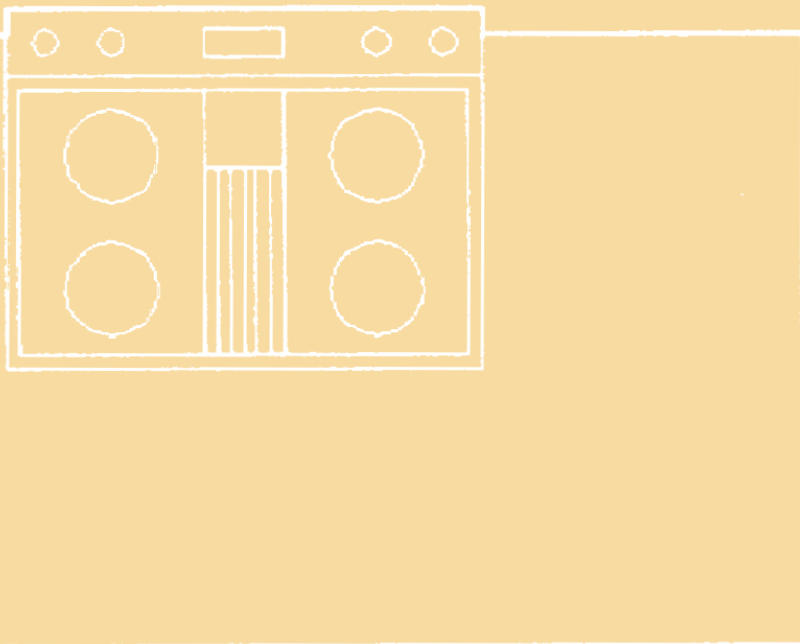

THE **REHAB** GUIDE

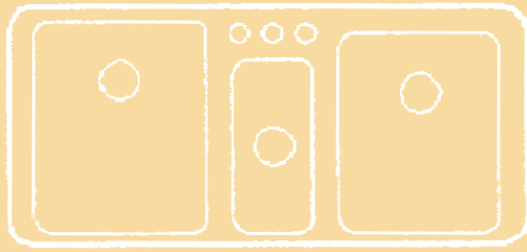

KITCHENS & BATHS



PATH (Partnership for Advancing Technology in Housing) is a new private/public effort to develop, demonstrate, and gain widespread market acceptance for the “Next Generation” of American housing. Through the use of new or innovative technologies the goal of PATH is to improve the quality, durability, environmental efficiency, and affordability of tomorrow’s homes.

Initiated at the request of the White House, PATH is managed and supported by the Department of Housing and Urban Development (HUD). In addition, all Federal Agencies that engage in housing research and technology development are PATH Partners, including the Departments of Energy and Commerce, as well as the Environmental Protection Agency (EPA) and the Federal Emergency Management Agency (FEMA). State and local governments and other participants from the public sector are also partners in PATH. Product manufacturers, home builders, insurance companies, and lenders represent private industry in the PATH partnership.

To learn more about PATH, please contact:

PATH
Suite B 133
451 7th Street SW
Washington, DC 20410
202-708-4250 (fax)
e-mail: pathnet@pathnet.org
website: www.pathnet.org

DISCLAIMER

The statements and conclusions contained in this report are those of Steven Winter Associates, Inc. and do not necessarily reflect the views of the Department of Housing and Urban Development. Steven Winter Associates, Inc. has made every effort to verify the accuracy and appropriateness of the report’s content. However, no guarantee of the accuracy or completeness of the information or acceptability for compliance with any industry standard or mandatory requirement of any code, law, or regulation is either offered or implied. The products listed in the report are included only as examples of some available products. No endorsement, recommendation, or evaluation of these products or their use is given or implied.

KITCHENS & BATHS

VOLUME 6 OF THE REHAB GUIDE

TABLE OF CONTENTS

FOREWORD **3**

1. INTRODUCTION **4**
2. KITCHEN & BATH OVERVIEW **6**
3. CABINETS **10**
4. COUNTERTOPS **25**
5. APPLIANCES **36**
6. SINKS & LAVATORIES **49**
7. TUBS & SHOWERS **57**
8. TOILETS & BIDETS **67**

APPENDIX: PROFESSIONAL ASSOCIATIONS & RESEARCH CENTERS **73**

Prepared for:
U.S. Department of Housing
and Urban Development
Office of Policy Development
and Research

Prepared by:
Steven Winter Associates, Inc.
Building Systems Consultants
Norwalk, CT

Contract DUI00C000005956
September 1999

CREDITS

STEVEN WINTER ASSOCIATES, INC. STAFF MEMBERS
WHO WERE INSTRUMENTAL IN THE DEVELOPMENT AND
PRODUCTION OF THIS GUIDEBOOK INCLUDE:

Steven Winter
Principal-in-charge

Michael J. Crosbie, Ph.D., RA
Project manager and Editor-in-chief

Masaki Furukawa
Illustrator

STAFF MEMBERS OF MARY JO PETERSON, INC.,
SUB-CONTRACTOR, WHO WERE INSTRUMENTAL
IN THE DEVELOPMENT AND PRODUCTION
OF THIS GUIDEBOOK INCLUDE:

Mary Jo Peterson
President

Terri McBride
Design Consultant

U.S. DEPARTMENT OF HOUSING AND URBAN DEVELOPMENT
OFFICE OF POLICY DEVELOPMENT AND RESEARCH, AFFORDABLE
HOUSING RESEARCH AND TECHNOLOGY DIVISION

David Engel
Director

Nelson Carbonell
Senior architect

GUIDEBOOK DESIGN

Andrew P. Kner
Art Director

Michele L. Trombley
Assistant Art Director

Elizabeth Rosen
Symbols

FOREWORD

President Clinton recognizes that research and technological innovation are crucial if America is to meet its affordable housing needs. In 1998, the President introduced a major new initiative: The Partnership for Advancing Technology in Housing (PATH). This initiative brings together leaders from the home building, product manufacturing, insurance, and financial industries, as well as representatives from federal agencies, to spur housing design and construction innovations.

Thanks to the development of new machinery and materials and the creation of new technologies and techniques, the construction industry has made great progress. But a breakthrough material, a labor-saving tool, or a cost-cutting technique is only valuable if it is widely adopted, which means the construction industry must first become aware of these new developments.

The Department of Housing and Urban Development can help. We have commissioned a set of guidebooks that will present state-of-the-art techniques, materials, and technologies for housing rehabilitation. This volume, *Kitchens & Baths*, is the sixth of nine guidebooks—known collectively as *The Rehab Guide*—that will appear over the next few years.

We are presenting these guidebooks because, like research and technological innovation, housing rehabilitation is an essential component of America's commitment to provide affordable housing. I am pleased to present this important publication in the hope that it will become a valuable resource that leads to affordable, high quality rehabilitation, and thus to better housing for all Americans.

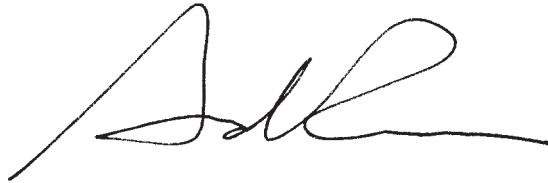

Andrew Cuomo, Secretary
U.S. Department of Housing and Urban Development

1

INTRODUCTION

This series of guidebooks has been produced by the U.S. Department of Housing and Urban Development to keep the design and construction industry abreast of innovations and state-of-the-art practices in home rehabilitation. As is too often the case, innovative techniques, materials, technologies, and products are slow to make their way into accepted practice. It is evident that such innovations will not advance unless the industry is made aware of them and they are tested. *The Rehab Guide* is intended to accelerate this process by informing builders, architects, engineers, and other housing rehabilitation professionals about such innovations and state-of-the-art practices.

The Rehab Guide was also prompted by the lack of a comprehensive publication to make the design and construction industry aware of innovative and cost-saving developments in housing rehabilitation. Professional trade magazines, conferences, and trade shows offer some dissemination of this information, but they are rarely focused exclusively on housing rehabilitation, as this series is, nor are they comprehensive.

FOCUS OF THE REHAB GUIDE

The focus of this series is on housing rehabilitation, which is different than home improvement. Rehabilitate means “to restore to good condition,” not necessarily to improve to a state that is significantly different than the original. This is a fine line, but it distinguishes this series from “home improvement” books written for the amateur. *The Rehab Guide* focuses on building technology, materials, components, and techniques rather than “projects” such as adding a new room, converting a garage into a den, or finishing an attic. Nor is *The Rehab Guide* intended to be a “diagnostic” tool; a number of such books are already available to the industry.

The content for this guidebook, *Kitchen & Baths*, has been gathered from professionals in the housing rehabilitation field; manufacturers and suppliers of innovative technologies, materials, components, tools, and equipment; trade shows, conferences, reports, and publications considering such issues; trade organizations; and building research centers.

A NOTE ON SOURCES

A variety of excellent resources exists for information on kitchen and bathroom systems and issues. *The Kitchen and Bath Industry Technical Manuals*, published by the National Kitchen and Bath Association, include resource books that address mechanical systems, construction considerations, function, design elements, equipment, and products relating to kitchens and bathrooms. A comprehensive source for manufacturers of cabinetry, hardware, appliances, fixtures, fittings, surface materials, and other products relating to kitchens or baths is available from *Kitchen and Bath Business* and *Kitchen and Bath Design News*.

Helpful information is also accessible via the Internet. Most equipment manufacturers and monthly magazines have Web sites where specific product information and past articles can be retrieved. The Department of Energy provides a wealth of information on energy conserving techniques and technologies at www.eren.doe.gov/consumerinfo/.

LEAD PAINT HAZARD

The hazard of lead paint in houses constructed before the 1980s is not discussed in the *The Rehab Guide* because there is extensive material available from HUD, the Environmental Protection Agency (EPA), and other sources. However, if you are a non-profit or rehab contractor rehabilitating pre-1978 housing for sale or rent, or if you are a homeowner rehabilitating a home for your own use, you are strongly urged to have the home tested for lead paint. This is especially critical if the home will be occupied by young children. Very small amounts of lead in paint or dust can poison children if swallowed or inhaled, causing damage to the brain and other organs, resulting in health problems and reduced intelligence. If lead paint is found, it is critical that all

rehabilitation be done very carefully to reduce the possibility of lead poisoning to you or your workers. Proper work practices will minimize the risk of spreading lead contamination and increasing occupant exposure.

One of the best and most recent sources on this subject is the HUD publication, “Lead Paint Safety: a Field Guide for Painting, Home Maintenance, and Renovation Work.” Another good publication is the EPA brochure, “Reducing Lead Hazards When Remodeling Your Home.” Both can be obtained by calling the National Lead Information Center at 800-424-LEAD or by downloading from the web site of the HUD Office of Lead Hazard Control, www.hud.gov/lea. A very comprehensive source is the HUD publication, “Guidelines for the Evaluation and Control of Lead-Based Paint Hazards in Housing,” which gives guidance on controlling lead hazards, lead paint and rehab work, risk assessment, monitoring, inspections, resident and work site preparation, worker protection, and routine building maintenance. This publication is available through HUD-User; you can also download a copy of this document from the HUD web site at: www.hud.gov/80/lea/learules.html.

HUD has new regulations on lead-based paint hazards in federally owned housing and housing receiving federal assistance. If you will be using HUD funds for rehabilitation through grants, insurance, or other types of assistance, then there are protective procedures that must be followed. The Occupational Safety and Health Administration web site at www.osha.gov has information on worker protection requirements. In addition, many states and localities have their own rules regarding lead-based paint, which should be followed when undertaking rehabilitation.

HOW THE GUIDE IS ORGANIZED

Nine volumes make up *The Rehab Guide* in its entirety, and they are listed on the back cover of this volume. (They can be ordered by contacting HUD User, P.O. Box 6091, Rockville, MD 20849; 800-245-2691; www.huduser.org.) Each one is devoted to distinct elements of the house, and within each volume is a range of issues that are common to that element of home rehabilitation work. This volume covers topics from materials for the repair of an existing fixture to the criteria for selection of an entirely new kitchen or bath system. Each volume addresses a wide range of techniques, materials, and tools, and recommendations based on regional differences around the country. Throughout *The Rehab Guide*, special attention is given to issues related to energy efficiency, accessible design, and sustainability.

The Rehab Guide is written and presented in a format intended for easy use. The spiral bound volumes open flat so that they can be easily photocopied, and they can be assembled and stored in a single three-ring binder. Within each volume, drawings, photos, and other graphic materials supplement written descriptions of a broad range of items: state-of-the-art and innovative building technology, products, materials, components, construction and management techniques, tools, equipment, software—virtually any and all items that make housing rehabilitation more efficient in terms of cost and time. While the content focuses on present technologies and techniques that are currently part of the house-building industry, *The Rehab Guide* also includes information on materials, products, and procedures from other construction sectors (such as commercial, industrial, institutional) that are relevant to housing rehabilitation.

The information is organized in different sections according to rehab subjects, and under headings that make this book easy to understand. “Essential Knowledge” gives the reader a basic overview of the important issues related to the section heading. Next, “Techniques, Materials, Tools” presents state-of-the-art and innovative approaches to accomplishing the work. Each entry is explained in detail, including its advantages and disadvantages. This makes it easy for readers to compare approaches and choose the one that is most applicable to their particular project. By design, the “Techniques, Materials, Tools” section is an overview, not a detailed description of implementation. “Further Reading” lists the valuable resources relevant to the subject that readers can go to for more detailed information. Finally, “Product Information” provides names and addresses of manufacturers of products, materials, systems, and components mentioned in the text so that more information can be obtained. By virtue of their being listed here, such products are not necessarily being recommended; their existence and availability are being brought to the reader’s attention. New products should be carefully evaluated in the field as to their performance. The product lists are not necessarily comprehensive, and we encourage readers to bring new materials and products to our attention to be included in later editions of *The Rehab Guide*.

2

KITCHEN & BATH OVERVIEW

The rehab specialist might have to rethink the kitchen and bath when called on to restore these areas. These two rooms are used by every member of the household every day, and they have systems with component parts that must function in harmony for the space to work. The National Kitchen and Bath Association has developed two books, *41 Guidelines of Bathroom Planning* and *40 Guidelines of Kitchen Planning* to address function, storage, layout, safety, access, design assistance, and product selection.

Being the most used rooms in any home, the kitchen and bath will likely be ripe for rehab work. Appliances and other equipment and fixtures become worn, obsolete, or energy hogs as they age. The preparation of food, and high moisture levels in both the kitchen and bathroom, take their toll on finishes, particularly counter tops, cabinets, and floors.

Traditionally, the kitchen “work triangle” is comprised of the sink, range, and refrigerator (Fig. 1). According to the National Kitchen and Bath Association, each leg of the triangle should be between 4’ and 9’ long to reduce the walking distance between the sink, range, and refrigerator. The work triangle should be outside of traffic patterns through the house so preparation is uninterrupted. In older homes, the back door and stairs to the basement are often off of the kitchen, and the only route is through the center of the kitchen and usually through the work triangle. Improving the function of the kitchen might involve changing the shape of the space by adding a peninsula or island. Although the parameters of the room dictate the size of the kitchen, its shape depends on the layout and combination of the work triangle and activity centers. Common shapes include the one wall kitchen, corridor-shaped kitchen, L-shaped kitchen, and U-shaped kitchen.

When possible, a rehab project should incorporate these work triangle guidelines into the layout of the kitchen to enhance its flow and efficiency. Lifestyle trends have changed the way these spaces are used. The kitchen has gone from a preparation area where one person cooks and serves meals, to the central living center where food preparation, household tasks, and socializing are combined. To support this centralized-family concept, the kitchen may also include centers of activity such as the secondary sink center, an additional microwave oven center, serving center, home office center, media center, and socializing center.

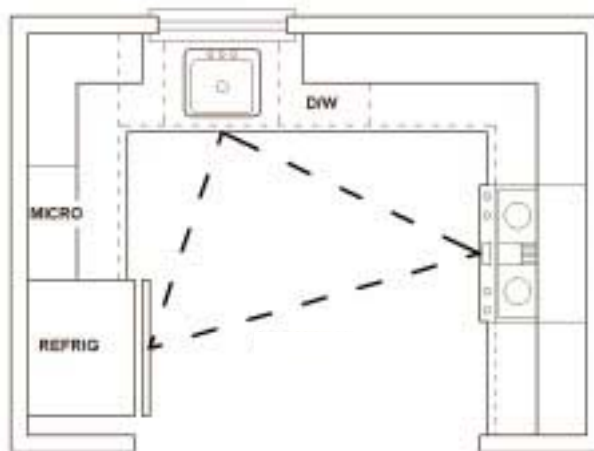

FIGURE 1A

U-SHAPED KITCHEN

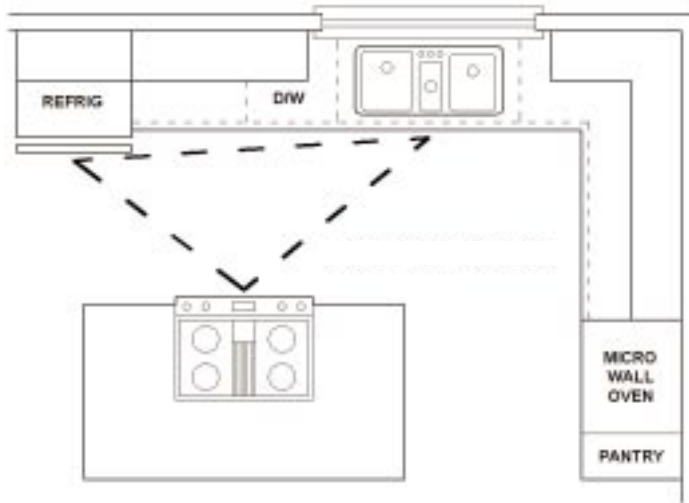

FIGURE 1B L-SHAPED KITCHEN WITH ISLAND



FIGURE 1C L-SHAPED KITCHEN

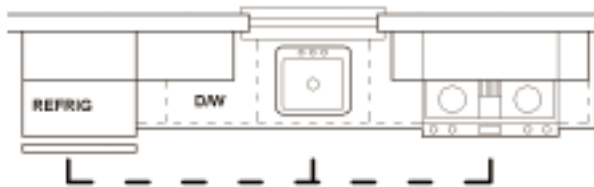

FIGURE 1D ONE-WALL KITCHEN

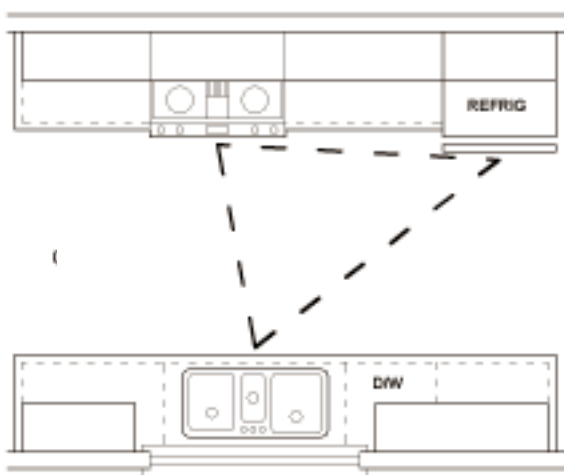

FIGURE 1E CORRIDOR-SHAPED KITCHEN

Time constraints and stress also affect today's kitchen and bathroom. With most homeowners' time being at a premium, efficiency in the kitchen and bathroom is critical, and technology is having an impact on the way the kitchen and bathroom are used, as well as on the products available. Today the height of the sink or work surface can be adjusted with the touch of a button, or a chicken can be roasted in a fraction of the time it used to take. In the bathroom, a combination of rehabed fixtures and finishes with new technologies will enhance efficiency. When space is minimal, the bath tub, if not the only one in the home, is often exchanged for an oversized shower, often with a seat, grab bars, dual shower heads, body sprays, or steam.

The most essential element in rehabing a kitchen or bathroom is the need to incorporate universal design. With household members of every age, stature, and level of physical ability, the issues of safety and access within the existing space should be addressed. The Center for Universal Design has developed a set of principles that can serve as a guide to the rehab professional.

- *Equitable Use*: The design of products and environments is usable by all people to the greatest extent possible, without the need for adaption or specialized design.
- *Flexibility in Use*: The design accommodates a wide range of individual preferences and abilities.
- *Simple and Intuitive Use*: The design is easy to understand, regardless of the user's experience, knowledge, language skills, or current concentration level.
- *Perceptible Information*: The design communicates necessary information effectively to the user, regardless of ambient conditions or the user's sensory abilities.
- *Tolerance for Error*: The design minimizes hazards and the adverse consequences of accidental or unintended actions.
- *Low Physical Effort*: The design can be used efficiently and comfortably and with a minimum of fatigue.
- *Size and Space for Approach and Use*: Appropriate size and space is provided for approach, reach, manipulation, and use regardless of user's body size, posture, or mobility.

In addition, references to the clear floor space throughout the Kitchen & Bath volume are minimums for people who use stationary seats, walkers, crutches, or wheelchairs while using or working at a fixture, appliance, or piece of equipment. Because of the way the kitchen and bathroom are used today, awareness of the need for concepts and products that adapt to the user rather than the reverse, has increased; responsible rehab specialists will improve kitchens or bathrooms by attending to these details.

FURTHER READING

Bathroom Industry Technical Manual; Volume #1, Building Materials, Construction, and Estimating for the Kitchen and Bathroom, MaryLee McDonald, Ellen Cheever, CKD, CBD, ASID; and Nicolas Geragi, CKD, CBD, National Kitchen and Bath Association, 1997.

Bathroom Industry Technical Manual; Volume #2, Bathroom Mechanical Systems, MaryLee McDonald, Ellen Cheever, CKD, CBD, ASID; and Nicolas Geragi, CKD, CBD, National Kitchen and Bath Association, 1997.

Bathroom Industry Technical Manual; Volume #3, Bathroom Equipment and Materials, Ellen Cheever, CKD, CBD, ASID, National Kitchen and Bath Association, 1997.

Bathroom Industry Technical Manual; Volume #4, Bathroom Planning Standards and Safety Criteria, Ellen Cheever, CKD, CBD, ASID, National Kitchen and Bath Association, 1997.

Bathroom Industry Technical Manual; Volume #5, Design Principles for Bathroom Planning, Ellen Cheever, CKD, CBD, ASID, National Kitchen and Bath Association, 1997.

Kitchen and Bathroom Carpentry: Installation Techniques, Jerry Germer, National Kitchen and Bath Association, 1997.

Kitchen and Bathroom Installation Manual, Volume #1, Walter W. Stoeppelwerth, National Kitchen and Bath Association, 1994.

Kitchen and Bathroom Installation Manual; Volume #2, Installation Project Management, Walter W. Stoepelwerth, National Kitchen and Bath Association, 1995.

Kitchen Industry Technical Manual; Volume #1, Building Materials, Construction, and Estimating for the Kitchen and Bathroom, MaryLee McDonald, Ellen Cheever, CKD, CBD, ASID; and Nicolas Geragi, CKD, CBD, National Kitchen and Bath Association, 1996.

Kitchen Industry Technical Manual; Volume #3, Kitchen Equipment and Materials, Ellen Cheever, CKD, CBD, ASID, National Kitchen and Bath Association, 1996.

Kitchen Industry Technical Manual; Volume #4, Kitchen Planning Standards and Safety Criteria, Ellen Cheever, CKD, CBD, ASID, National Kitchen and Bath Association, 1996.

Kitchen Industry Technical Manual; Volume #5, Design Principles for Kitchen Planning, Ellen Cheever, CKD, CBD, ASID, National Kitchen and Bath Association, 1996.

“The Principles of Universal Design,” The Center for Universal Design, North Carolina State University, April 1, 1997; www.design.ncsu.edu/cud/pubs/udprinciples.html.

Universal Kitchen and Bath Planning, Mary Jo Peterson, CKD, CBD, CHE, New York: McGraw-Hill, 1998

3

CABINETS

3.1

SURFACE MAINTENANCE AND REPAIRS

ESSENTIAL KNOWLEDGE

Cabinetry is most commonly made from a combination of plywood or fiberboard with laminate, veneer, or a vinyl or foil wrap as the finish material. Repeated abrasion and standing moisture are the two major sources of damage and deterioration to the finish on kitchen and bath cabinetry. Once the finish is disturbed, cabinet surfaces, particularly fiberboard, can rapidly deteriorate, absorbing moisture and degrading not only in appearance but function, mainly the doors and drawers. Successful resolution requires refinishing, repair, or replacement of cabinetry fronts or entire cabinets.

TECHNIQUES, MATERIALS, TOOLS

Options for restoring the exterior of cabinetry include:

1. TOUCH-UP OR PATCH SURFACES.

Cracks or gaps in seams or on the wood surface can be filled with wood or seam fill products such as Kampel's Woodfil or Seamfil. In the case of less expensive cabinets, edges or interiors may never have been sealed. Multiple coats of a sealer help cut down on volatile organic compound (VOC) outgassing in the home.

ADVANTAGES: Discourages or stops further moisture absorption.

DISADVANTAGES: May be a noticeable difference in the appearance between the filler and the original, particularly in wrapped, veneered, or laminate finishes. Although the coats of sealer reduce emissions of VOCs, they do not completely stop them. Some of the products have an odor during application.

2. REFINISH SURFACES.

On the solid wood portions of the cabinetry, existing stains can be stripped. Ideally, this will include the face frame, doors and drawer fronts, exposed ends and trim. A diluted solution of trisodium phosphate and water sponged on the surface will remove grime, cooking grease, and layers of wax. Lightly sand the surface with the grain to smooth. The stripping should be done outside or in a well ventilated area. A new stain or paint can be applied and then a sealer to complete the process. Greater success may result in subcontracting to a specialist to do the finishing, particularly if a faux finish or unusual paint finish is desired.

ADVANTAGES: Can dramatically change the appearance and rejuvenate the wood. Material cost is relatively low. Tremendous variety is available with faux finishes, paints, and glazes.

DISADVANTAGES: Time and labor intensive. This finish will not usually be as durable as a manufacturer's. Aside from limited success with painting, this process does not work for veneer, laminate, or wrapped finishes.

3. REFACE FRONTS AND SIDES.

Cabinetry made from the most common materials—wood or fiberboard with veneer, laminate, or vinyl wrap—can be refaced, provided the surfaces are uniform and devoid of significant ornamentation. Laminate or veneer is applied to exposed or visible surfaces using an adhesive backing or less toxic contact cement such as Elmer's Safe-T to suit the material.

ADVANTAGES: Somewhat less costly than replacing cabinetry.

DISADVANTAGES: Will not work on doors or drawer fronts with multiple levels; does not restore frayed or gouged edges or surfaces.

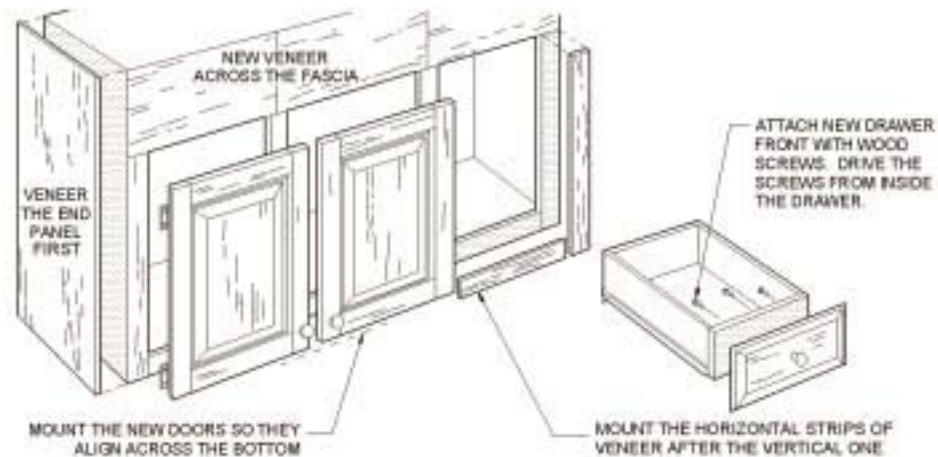

FIGURE 1

CABINET REFURBISHMENT

4. REPLACE CABINET DOORS AND DRAWER FRONTS.

Usually limited to framed cabinetry, the face frame and case can be maintained in the original finish, and doors and drawer fronts can be replaced in a complementary finish, providing a pleasing contrast (Fig. 1). The contrast can be extended to toekicks, counter trim, light valances, or other moldings.

ADVANTAGES: Cuts down on labor and eliminates the need to strip or match existing finishes. Replaces damaged door and drawer fronts and provides for the addition of new cabinetry that might improve the function of the space.

DISADVANTAGES: Does not resolve damage in the case or face frame; requires strong cases and joints.

FURTHER READING

The Healthy Household, Lynn Marie Bower, Healthy House Institute, 1995.

Prescriptions for a Healthy House, Paula Baker, AIA; Erica Elliot, MD; John Banta, InWord Press, 1998.

Refacing Cabinets; Making an Old Kitchen New, Herrick Kimball, Taunton Press, 1997.

“Steps to Refacing Kitchen Cabinets,” Edward, R. Lipinski, *The New York Times*, July 19, 1998.

PRODUCT INFORMATION

Elmer’s Adhesives, Division of Borden, Inc., 180 E. Broad St., Columbus, OH 43215; 800-648-0074; 218-436-2482 (fax).

Kampel’s Ent., Inc., Wellsville, PA 17365-0157; 717-432-9688; 717-432-5601 (fax).

Kitchen Tune-Up, 813 Circle Drive, Aberdeen, SD 57041; 800-333-6385; 605-225-1371 (fax); www.kitchentuneup.com.

3.2

HARDWARE TO MAXIMIZE ACCESS AND FUNCTION

ESSENTIAL KNOWLEDGE

Hinges, pulls, or drawer glides that are worn function poorly, if at all. Cabinetry that does not maximize storage or is not accessible to a variety of people can be modified for easy access. Concerns include not only inconvenience, but also safety hazards. Short of a total “gut and renovation,” there are solutions that involve replacing hardware or adding accessories.

TECHNIQUES, MATERIALS, TOOLS

1. REPLACE PULLS OR KNOBS.

Open pull or D-ring handles on doors and drawers are recommended because they allow people of all ages and abilities to easily access the cabinet. The smooth D-ring is preferred over handles with square corners or pointed ends because minor accidents such as bumping the hip or head can be avoided. If existing drilled holes do not have the same center dimension as the new hardware, cover-plates can be used between the pull and the door or drawer front (Fig. 2).

ADVANTAGES: Adding new hardware will update the existing cabinetry, and allow even a weak hand to easily access the cabinet door and drawer.

DISADVANTAGES: Cover-plates may discolor or age at a different rate than exposed cabinetry.



FIGURE 2

COVER-PLATE TO COVER EXISTING DRILLED HOLES

2. REPLACE HINGES.

Depending on the quality of original door hinges and the level of wear and tear, the existing condition may include doors that will not stay closed, won't close at all, or do not align. Some hinges will allow adjustment to improve the situation; replacing the hinges will otherwise eliminate the problem. In order to replace hinges, it is first necessary to determine the door and case style. Cabinet cases are typically framed or frameless, and typical door styles are inset, standard offset, or marginal overlay and full overlay (see Section 3.4, REPLACE OR ADD CABINETS for typical cabinet case and door types). Based on an examination of the existing hinge and its installation and condition, one can choose knife, concealed, or various barrel hinges (Fig. 3).

ADVANTAGES: Variations in quality and style are available in hardware today; the improvement can be significant.

DISADVANTAGES: The new hinges must be compatible with the type and installation of the hinges being replaced.

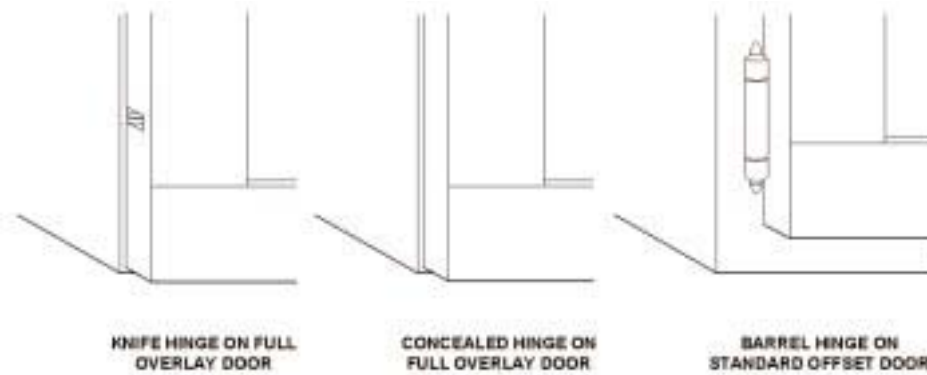

FIGURE 3

KNIFE, CONCEALED, AND BARREL HINGES

3. UPGRADE TO SPECIALTY BIFOLD HINGES TO IMPROVE ACCESS.

Where space is tight or mobility and endurance are an issue, converting existing hinges to a bifold system improves access, reducing the space required for the door swing by half. These hinges allow the door, which is cut lengthwise into two doors half the size of the opening, to be moved to the right or left of the cabinet. An additional piece of hardware prevents the door from swinging wide.

ADVANTAGES: Can be used in corner cabinets to improve access or under sinks or cooktops to create a storage/knee space for a seated cook. Allows door to open in approximately half the traditional space, increasing clear floor space for access (Fig. 4a and 4b).

DISADVANTAGES: Adjacent obstructions, such as dishwashers or hoods, inhibit the door/hinge from opening to its full swing.

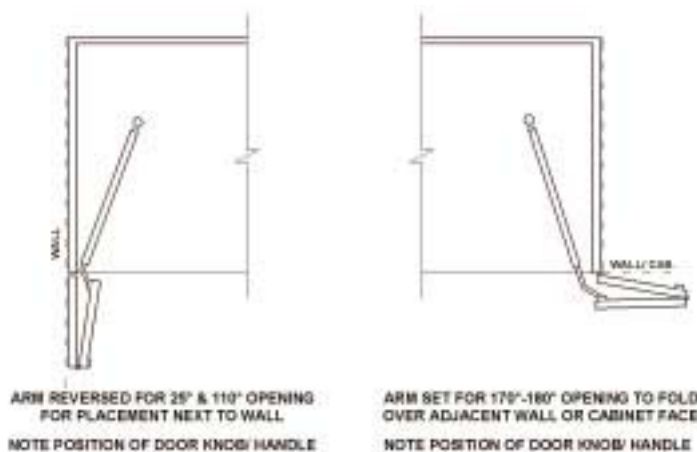

FIGURE 4A

EZYFOLD HINGE DETAILS



FIGURE 4B

EZYFOLD HINGE

4. UPGRADE TO SPECIALTY RETRACTABLE DOOR HINGES.

These hinges allow the doors to open to 90% and then slide back just inside either side of the cabinet (Fig. 5).

ADVANTAGES: Cabinet doors can stay open with no obstruction in front of the unit. Commonly used with television cabinets, but can also be used to house a waste receptacle that can be left exposed when in use. Also creates a knee space in a base cabinet for a seated user.

DISADVANTAGES: The hardware and retracted doors will consume interior cabinet space, as much as 3" per side, which can be critical if the space is being used as a knee space. Less than top quality retracting hinges require ongoing adjustment.



FIGURE 5

RETRACTABLE DOOR HINGE IN BASE CABINET

5. INSTALL UP-SWINGING HINGES.

These hinges carry the door up and sometimes over the cabinet (Fig. 6).

ADVANTAGES: Moves wall cabinet door out of the path of cook.

DISADVANTAGES: Only applies to wall or upper sections of cabinetry, and can move the door out of the reach of shorter or seated cooks.

6. UPGRADE TO DROP-DOWN DOOR HINGE.

These hinges allow a door to hinge at its bottom with locking side bars to control how far the door opens.

ADVANTAGES: Improves access for bins or hampers used for storing bulk items (dog food, recycle bin, laundry hampers, or access under a seating area).

DISADVANTAGES: Limited application.

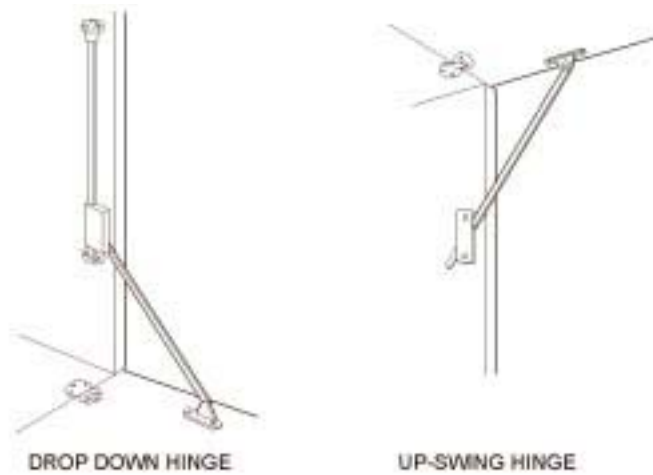

FIGURE 6

DROP-DOWN AND UP-SWING HINGES

7. REPLACE OR UPGRADE TO BOTTOM-MOUNT DRAWER GLIDES.

The most popular form of drawer hardware, this type of system is installed on the bottom of the drawer (Fig. 7). It offers smooth and quiet operation and allows for construction of a larger drawer box.

ADVANTAGES: Bottom location of the glide allows for a cleaner appearance. Glides can be adjusted over time as use requires.

DISADVANTAGES: Glides will not easily fit onto existing drawers that have previously had traditional side-mounted glides. Glides are not commonly able to feature full extension.

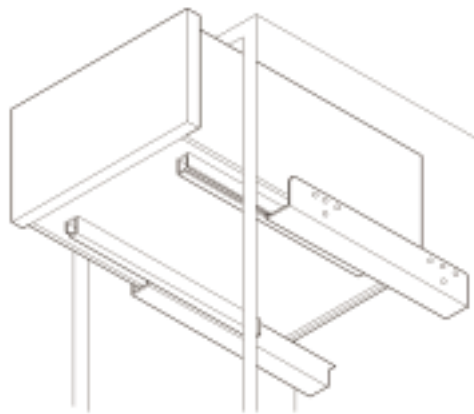

FIGURE 7

BOTTOM-MOUNT DRAWER GLIDE

8. REPLACE OR UPGRADE TO SIDE-MOUNT DRAWER GLIDES.

These glides are available in a variety of types, from inexpensive and no frills, to more high-end with bearing movement and integral adjustment (Fig. 8).

ADVANTAGES: Can be inexpensive, least labor to install. Can include a self-closing feature.

DISADVANTAGES: May have no provision for adjustment so maintenance can be more difficult. Lower priced versions operate less smoothly, with more noise and effort.

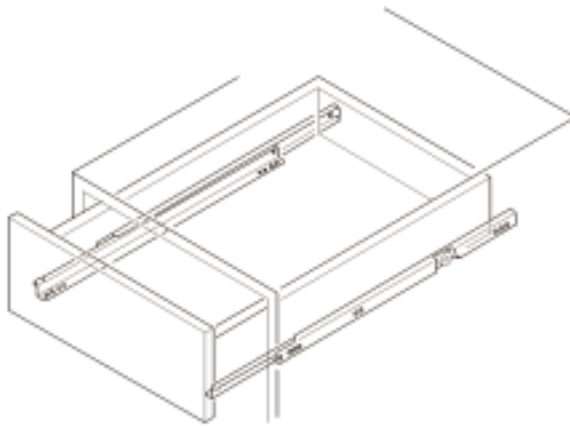

FIGURE 8

SIDE-MOUNT DRAWER GLIDE

9. REPLACE OR UPGRADE TO FULL-EXTENSION DRAWER GLIDES.

Typically side-mounted, these glides provide easy access to the entire drawer and often support heavier storage (Fig. 9).

ADVANTAGES: Complete access to drawer contents without bending or reaching. These glides are typically rated to support heavier weights.

DISADVANTAGES: These glides are usually bulkier, less smooth, and more difficult to operate.

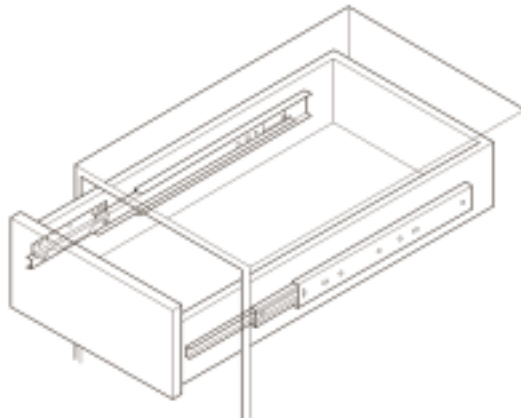

FIGURE 9

FULL-EXTENSION DRAWER GLIDE

FURTHER READING

“1999 Buyer’s Guide,” *Kitchen and Bath Business*, Feb. 1999.

“Annual Directory and Buyer’s Guide,” *Kitchen and Bath Design News*, Feb. 1999.

Universal Kitchen and Bath Planning, Mary Jo Peterson, CKD, CBD, CHE, McGraw-Hill, 1998.

PRODUCT INFORMATION

Hafele, PO Box 4000, 3901 Cheyenne Drive, Archdale, NC 20263; 919-889-2322; 800-423-3531; 910-431-3831 (fax); www.hafeleus.com.

Julius Blum, Inc., 7733 Old Plank Road, Stanley, NC 28164; 800-438-6788; 794-827-0799 (fax); www.blum.com.

Kiwi Connection, Ezyfold Hinge, 82 Shelburne Center Road, Shelburne, MA 01370; 413-625-2854; 413-625-6014 (fax).

3.3

ACCESSORIES TO MAXIMIZE ACCESS AND IMPROVE STORAGE

ESSENTIAL KNOWLEDGE

Acknowledgment of the human aging process and increasing appreciation for the diversity of physical characteristics in household members have changed the approach to access and storage in both the kitchen and the bathroom. In general, rehab work should take into account that access and storage can be improved by following basic universal design principles and practices (see Chapter 2). These guidelines establish flexibility and improve access and support to make the space useable by more types of people most of the time. Critical to access is creating storage and work centers within the comfort zone of most people. Storage should be concentrated in the universal reach range of 15" to 48" above finished floor height, and near its point of use. Work surface heights should vary to accommodate standing or seated people of varying heights. While the kitchen or bath cannot be totally redesigned when keeping existing cabinetry in rehab work, much can be done to enhance the storage and other functional aspects of the space.

TECHNIQUES, MATERIALS, TOOLS

The following are examples of accessories available in a range of costs with a variety of benefits to improve existing cabinetry:

1. INSTALL A STEP STOOL.

Step stools can easily be installed on the inside of a base or tall cabinet door for use in a single location, or they may be stored in either of these spaces or in the toekick of a cabinet, to be removed and used where desired (Fig. 10). Typical units store in 4" of space and unfold to a height of 15" as single-step units or higher in the two-step version. Both Hafele and Rev-A-Shelf offer step stool accessories.



Photo: GE

FIGURE 10

REVA-SHELF STEP STOOL INSTALLED ON DOOR TO IMPROVE ACCESS

ADVANTAGES: Provides safer access to storage above the universal reach range. Built-in units provide storage at the point of use. Easy to accomplish in a rehab project.

DISADVANTAGES: Deeper units may absorb some base cabinet storage. Built-in units can only be used where installed.

2. IMPROVE CORNER STORAGE.

A corner revolving shelf or corner swing-out shelf will improve access to previously blind corners (Fig. 11). Recent needs for recycling have brought responsive design in the form of rotating multiple bins that make good use of the otherwise poor storage in the corners.

ADVANTAGES: Improves access.

DISADVANTAGES: To fit within the cabinet, the movable storage is often smaller than the overall space available. Successful installation in rehab requires precise dimensioning of available interior space and the opening.

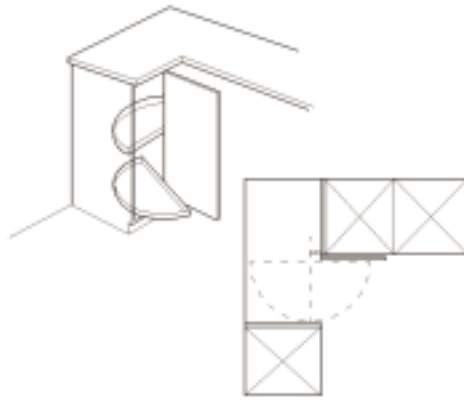

FIGURE 11

SWING-OUT SHELF TO IMPROVE ACCESS TO CORNER STORAGE

3. REPLACE FIXED SHELVES WITH ADJUSTABLE/ROLL-OUT SHELVES.

In wall, tall, or base cabinets, converting to adjustable shelves allows the homeowner to maximize storage (Fig. 12). In base or tall cabinets with a typical depth of ± 24 " roll-out shelves and accessories further increase access to storage. Note that when cabinet depth is less than 18" roll-outs are usually not necessary.

ADVANTAGES: Items can be easily stored and used without reaching into cabinets.

DISADVANTAGES: Weight of items to be stored must be considered for proper function of the roll-out shelf (hardware/shelf ratings for maximum load are usually available).



FIGURE 12

ROLL-OUT SHELVES IN BASE CABINET

4. INSTALL SPECIFIC PURPOSE ACCESSORIES.

Accessories are available to support recycling, tray storage, spice storage, appliance storage, and more (Fig. 13, 14, and 15). Typically, these accessories are designed to be removable to allow for flexibility in storage.

ADVANTAGES: Improves organization and efficiency.

DISADVANTAGES: Permanently installed items eliminate flexibility. After-market accessories often use less than the full cabinet interior.

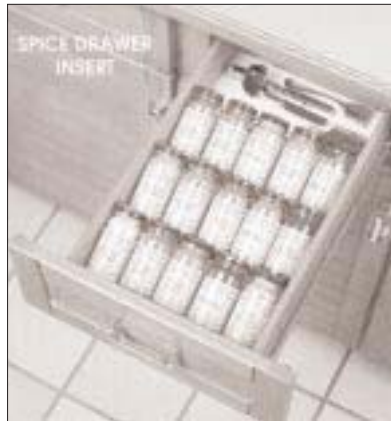

SPICE RACK IN DRAWER.
FEENY PHOTOGRAPH



BASE CABINET RECYCLING BINS.
REVA-SHELF PHOTOGRAPH



COSMETIC DRAWER DIVIDER.
FEENY PHOTOGRAPH

5. INSTALL BACKSPLASH STORAGE ACCESSORIES.

Easy to install “appliance garages” and railing systems supporting a variety of storage options can be added to an existing backsplash area to increase and improve flexible and accessible storage. Railing systems, manufactured by Hafele and Rev-A-Shelf, are growing in popularity. Storage provisions include knives and utensils, wraps, cutting boards, condiments and spices, paper towels, cookbooks, dish draining racks, and more (Fig. 16). Tambour, sliding, or (occasionally) hinged doors are installed in the backsplash below the wall cabinets, to conceal stored appliances. Including outlets provides true storage at the point of use.

ADVANTAGES: Increases and improves storage with easy installation in rehab situation.

DISADVANTAGES: Can be costly, can interfere with counter top use. In the case of appliance garages, appliances to be stored must be measured for a good fit.



Photo: GE

FIGURE 16

HAFELE BACKSPLASH RAILING SYSTEM

6. INSTALL HEIGHT-ADJUSTABLE STORAGE.

In existing cabinetry and design, wall cabinet storage can be made height-adjustable via an Accessible Design Adjustable Systems motorized unit or Hafele mechanical system (Fig. 17).

ADVANTAGES: Brings wall cabinet storage within the reach of most people. Growing use has brought the cost down.

DISADVANTAGES: Difficult to install in existing location and requires approximately 3" in depth, either in addition to cabinet depth or absorbed from cabinet depth. When used, cabinet in lowered position can interfere with counter.



FIGURE 17

ADAS ADJUSTABLE HEIGHT CABINET

FURTHER READING

“1999 Buyer’s Guide,” *Kitchen and Bath Business*, Feb. 1999.

“Annual Directory and Buyer’s Guide,” *Kitchen and Bath Design News*, Feb. 1999.

Kitchen Industry Technical Manual; Volume #4, Kitchen Planning Standards and Safety Criteria, Ellen Cheever, CKD, CBD, ASID, National Kitchen and Bath Association, 1996.

Universal Kitchen and Bath Planning, Mary Jo Peterson, CKD, CBD, CHE, McGraw-Hill, 1998.

PRODUCT INFORMATION

Accessible Designs Adjustable Systems, ADAS, 94 North Columbus Road, Athens, OH 45701; 740-593-5240; 740-593-7155 (fax).

Feeny Mfg., PO Box 191, 6625 Old State Rd. 3 North, Muncie, IN 47303; 765-288-8730; 765-288-0851 (fax); www.kv.com.

Hafele, PO Box 4000, 3901 Cheyenne Drive, Archdale, NC 20263; 919-889-2322; 800-423-3531; 910-431-3831 (fax); www.hafeleus.com.

Hinge-It Corp., 3999 Millersville Rd., Indianapolis, IN 46205; 800-599-6328; 317-542-9514; 317-542-9524 (fax); www.hingit.com.

Rev-a-Shelf, PO Box 99585, 2409 Plantside Dr., Jeffersontown, KY 40299; 800-626-1126; 505-499-5835; 502-491-2215 (fax); www.rev-a-shelf.com.

3.4

REPLACE OR ADD CABINETRY

ESSENTIAL KNOWLEDGE

In rehab projects where the condition, appearance, and layout of the existing cabinetry is deemed beyond repair, some or all of the cabinetry can be replaced. This may be the eventual outcome of a plan to replace other components of the space, or a desire to change the look and function of the space. It is important to recognize that this option allows for a change in the overall layout of the space, as none of the previous options do.

TECHNIQUES, MATERIALS, TOOLS

The most successful techniques for replacing cabinetry include:

1. DETERMINE CABINET CONDITION.

Before cosmetic rehabilitation is attempted, the cabinet’s structure and components should be examined. If the horizontal rails, vertical stiles, or side and back panels are warped and damaged, the cabinet may not be level or plumb. This will affect the fit when installed next to other cabinetry.

ADVANTAGES: Will save time and money of rehab if cabinet can be salvaged.

DISADVANTAGES: Mixing and matching cabinet pieces may result in a weak cabinet.

2. SUPPLEMENT EXISTING CABINETRY.

Before adding cabinetry to an existing or improved kitchen layout, the occupant’s dining needs and cooking and study habits should be determined (if possible). Refer to NKBA Guidelines for clearance dimen-

sions required around an island, between opposing work counters and relating to kitchen work centers. Tall units, such as pantries, should be placed at the end of a run to maximize continuous counter space and maintain an uninterrupted work triangle. Storage for canned goods is best at 12" deep, but 24" deep cabinetry may work better for appliances, and can be accessories for storage of canned goods. Shorter vanity cabinets add interest and function to an existing kitchen because a 30" to 33" high counter is the recommended height for a baking center, desk area, or seated work area.

ADVANTAGES: Creates separate areas within the kitchen to improve function.

DISADVANTAGES: Existing and new cabinet exteriors should complement rather than match each other. Detailed specifications should be examined to determine if existing and new cabinetry have the same toe-kick height, drawer head height, and overall height dimensions if they are to be placed next to each other.

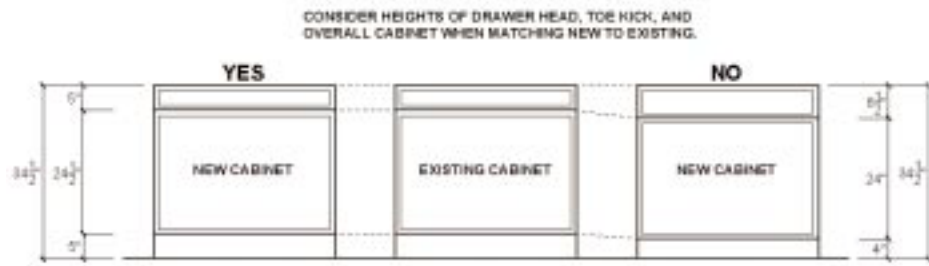

FIGURE 18

DRAWER AND TOEKICK HEIGHTS IN SUPPLEMENTARY CABINETS

3. SELECT TYPES OF CABINETY.

If existing cabinetry is supplemented with new cabinetry, the new cabinetry should have the same structure as the original. The construction will either be framed or frameless, and the door type will either be standard offset, full overlay, or inset (Fig. 19). When comparing construction of different cabinet lines, the joint technique, component parts thickness, hardware quality, and core materials should be examined. If unsure about the quality of cabinets, refer to the Kitchen Cabinet Manufacturers Association, which certifies cabinets that meet their performance standards. Typically, inset doors are more expensive than full overlay, and full overlay are more expensive than standard offset. Depending on the style of the kitchen or bathroom, the door styles can complement, yet differ, from one another.

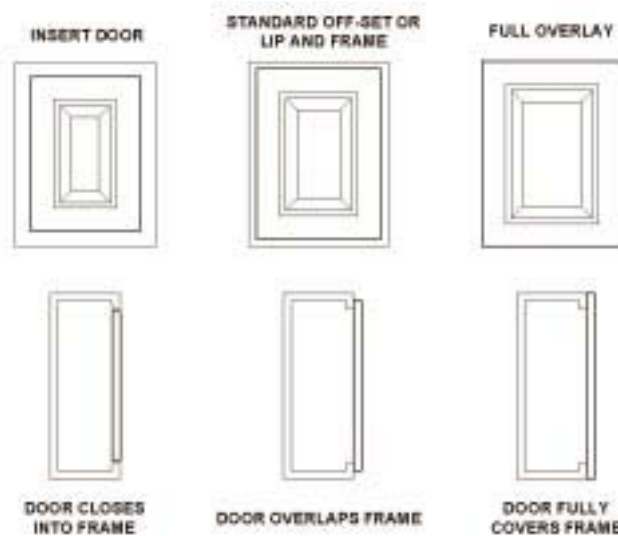

FIGURE 19

INSET, STANDARD OFFSET, AND FULL OVERLAY DOORS

3A. INSET DOORS.

Inset doors are set into the door frame.

ADVANTAGES: Has the look of craftsman-built or furniture quality.

DISADVANTAGES: Most expensive, requires most precision work to be done well; gives a strong traditional message, so this style is rarely used in contemporary kitchens.

3B. STANDARD OFFSET DOORS.

Standard offset doors extend slightly into face frame.

ADVANTAGES: Most reasonable in price and most forgiving of poor craftsmanship. The door laps the frame with additional space surrounding the door so there is room for adjustments; easier to conceal slight inaccuracies in door position; can appear traditional or as a transition to contemporary; can be used with concealed or visible hinges.

DISADVANTAGES: Edges of doors are exposed to damage.

3C. FULL OVERLAY.

Full overlay doors completely overlay front face frame.

ADVANTAGES: Clean lines, easy to clean, concealed hinge.

DISADVANTAGES: Door must be hung and adjusted accurately as there is often no frame behind it, and the look emphasizes precision.

4. IMPROVE INDOOR AIR QUALITY WITH CABINETY.

A growing concern for natural resources and the environment makes it critical to address resource efficiency and air quality. Neil Kelly Signature Cabinets addresses resource efficiency and indoor air quality concerns in its Naturals Collection. Certified wood components and environmentally friendly finishes are standard, and add-ons include a natural oil/wax finish and non-formaldehyde Medite II medium density fiberboard (MDF). Neff Cabinets offer 98% reduction in formaldehyde content. Metal cabinetry provides an attractive alternative to non-formaldehyde cabinet construction. Ampco, Arctic Metal Products, Dwyer Products, Cervitor, Heritage, and St. Charles distribute metal cabinetry with different options, styles, colors, and add-ons.

ADVANTAGES: Costs comparable to middle to high-end semi-custom cabinetry; conserves natural resources.

DISADVANTAGES: Limited door styles and finishes.

FURTHER READING

“1999 Buyer’s Guide,” *Kitchen and Bath Business*, Feb. 1999.

“Annual Directory and Buyer’s Guide,” *Kitchen and Bath Design News*, Feb. 1999.

Prescriptions for a Healthy House, Paula Baker, AIA; Erica Elliot, MD; John Banta, InWord Press, 1998.

The Healthy Household, Lynn Marie Bower, Healthy House Institute, 1995.

Kitchen Industry Technical Manual; Volume #3, Kitchen Equipment and Materials, Ellen Cheever, CKD, CBD, ASID, National Kitchen and Bath Association, 1996.

Kitchen Industry Technical Manual; Volume #4, Kitchen Planning Standards and Safety Criteria, Ellen Cheever, CKD, CBD, ASID, National Kitchen and Bath Association, 1996.

PRODUCT INFORMATION

Ampco, PO Box 608, Rosedale, MS 38769; 601-759-3521; 601-759-3721 (fax).

Arctic Metal Products Corp., 507 Wortman Ave., Brooklyn, NY 11208; 718-257-5277; 718-257-5277 (fax).

Cervitor Kitchens Inc., 10775 Loller Road, Almonte, CA 91731; 800- 523-2666; 818-443-0184; 626-443-0400 (fax).

Dwyer Products Corp., 418 N. Calumet Ave., Michigan City, IN 46360; 800-348-58508; 219-874-5236; 219-874-2823 (fax); www.dwyerkitchens.com.

Heritage Custom Kitchens, 215 Diller Ave., New Holland, PA 17557; 717-354-4011; 717-355-0169 (fax).

Neff Kitchen Manufacturers, 6 Melanie Drive, Brampton, Ontario, Canada L6T 4K9; 800-268-4527; 905-791-7770; 905-791-7788 (fax); www.neffweb.com.

Neil Kelly Naturals Collection, Neil Kelly Signature Cabinets, 804 N. Alberta, Portland, OR 97217; 503-288-6345; 503-288-27464 (fax); www.neilkelly.com.

St. Charles Manufacturing Co., 1611 E. Main St., St. Charles, IL 60174; 708-584-3800.

4

COUNTERTOPS

4.1

SURFACE MAINTENANCE AND REPAIRS

ESSENTIAL KNOWLEDGE

The most common materials used for kitchen and bath counter surfaces include laminate, solid surface, solid surface veneer, cultured stone, stone, tile, wood or butcher block, and (more recently) concrete and aggregate stone. None of these surfaces is indestructible, and a combination of knife scratches, chips, burns, or imperfect seams may occur over time. Wherever these blemishes are present, maintenance, bacteria, and further degradation of the surface increase. Prompt repair reduces health risks and further damage which is more difficult to repair.

TECHNIQUES, MATERIALS, TOOLS

Options for repair of counter surface blemishes relate directly to the surface material:

1. REPLACE LAMINATE SURFACES.

Laminate cannot be repaired, but a laminate counter can sometimes be salvaged if the substrate has not absorbed moisture. The damaged section can be cut out and an inset of a contrasting material such as tile, stone, or butcher block can be installed.

ADVANTAGES: The inset can enhance appearance and function of the top; tile or stone will be heat resistant and butcher block will provide a built-in cutting surface.

DISADVANTAGES: Repair of a laminate counter in place is labor intensive and the cost of repair may come close to the cost of replacing the tops, as laminate is a moderate priced material.

2. REPAIR CULTURED STONE.

Made from chips of natural stone embedded in a polyester resin, cultured stone is durable and easy to maintain. Cultured onyx consists of polyester resin and alumina trihydrate, which is combined to reproduce the veined appearance of natural onyx or alabaster. Cultured stone is also called cast polymer. Minor scratches can be buffed out using a polishing pad, and deep scratches or chips should be repaired by a porcelain repair company.

ADVANTAGES: Wide color and design options. Can be made in large sizes so there are no seams.

DISADVANTAGES: Scratches easily; may need waxing to maintain finish.

3. REPAIR AGGREGATE STONE.

New on the market, aggregate stone is made of natural stone particles in a polyester resin, and has the characteristics of natural stone at a lower cost. Silestone from Cosentino USA is an engineered stone that resembles granite. Aggregate stone can be repaired using the same techniques used for natural stone (see below, REPAIR OR REPLACE STONE).

ADVANTAGES: Has the look of natural stone without the cost.

DISADVANTAGES: Limited colors and product types.

4. REPAIR SOLID SURFACE.

Solid surface counter tops, such as Corian, are homogeneous materials such as polyester, acrylic, or a polyester and acrylic blend. Every manufacturer has developed a unique composition, some including mineral fillers to improve durability or fire-retardant properties. Because of the homogeneous makeup, scratches or burns in the solid surface can be removed with a scouring pad, 320-400 grit sandpaper, or steel wool. The manufacturer can refer a certified installer to repair more serious damage.

ADVANTAGES: Stains will not penetrate the non-porous surface, and minor scratches and burns can be buffed out.

DISADVANTAGES: The solid surface material will expand when hot, and will crack if a hot pot is placed on the surface. Deep cuts that cannot be buffed may need to be filled with the manufacturer's filler.

5. REPAIR OR REPLACE CERAMIC TILE AND GROUT.

Ceramic tile is heat resistant but varies in its resistance to scratches and chips. Tile counter tops are susceptible to water penetration, and if the grout between the tiles gets wet, water can seep behind the tile and damage the substrate. An individual tile or section of tile can be removed and replaced if a tile is chipped, cracked, or loses adhesiveness. Using a cold chisel, break the damaged tile into several pieces and pry the small sections of tile from the backer board. A chisel (rather than a hammer) will not cause damage to the substrate. Grout is porous and susceptible to cracks and stains, and repairs to the counter surface often involve removing the existing grout with a grout saw and regrouting between the tiles. Grout is available as cement, vinyl or epoxy-based. Epoxy-based grout is stronger and more impervious to water, mildew, and stains, but more care is required during installation. Penetrating or surface silicone cleaner applied to grout increases its stain resistance. Household cleaners containing acid, bleach, or vinegar should be avoided because they will etch the tile and grout over time.

ADVANTAGES: Though ceramic tile rarely chips, bacteria can collect in the damaged area. If extra tiles are available, this repair is relatively easy.

DISADVANTAGES: Care must be taken to remove tile without damaging surrounding tiles; a hand held grout saw or diamond blade grinder should be used. Sometimes difficult to match grout colors; epoxy based grouts tend to be more expensive than others.

6. REPAIR OR REPLACE STONE.

When polished and sealed, slate and granite are the most appropriate types of stone used for counter top application because of their durability. Although a fragile 3/4" thickness is available, a 1 1/4" thickness can support a 12" overhang, and it is stronger and thus easier to transport and install. Stone counters are available in slabs up to 4' wide and 9' long. If there are minor cracks or chips, the counter top can be repaired using an overfill and grind technique. The chipped or damaged area is cleaned and dried before it is filled with an epoxy or polyester matrix combined with a ground stone or sand aggregate to produce a mortar-like mixture. After the mixture cures, the fill is ground and polished. These repairs should only be done by an experienced professional. Any cracks in the surface can be repaired with the same mixture described above. Cracks repaired using the overfill and grind technique will be interpreted as a vein in the stone. To eliminate an obvious straight line man-made repair, the edges of the crack can be chipped and widened, replicating the existing veins.

ADVANTAGES: The aggregate repair will improve similarity between stone and fill.

DISADVANTAGES: Epoxies are structurally superior to polyester, but epoxy may yellow.

7. REPAIR OR REPLACE WOOD OR BUTCHER BLOCK.

Laminated maple counter tops can be used throughout the kitchen or as a butcher block insert. The unfinished wood will need to be oiled weekly with a mineral oil, and prefinished wood must be finished with a penetrating sealer and a non-toxic lacquer finish. Urethane varnish will protect a dining counter wood top from moisture and liquids, but it should not come in contact with foods, and should not be used as a chopping surface. Burns or deep scratches can be sanded and retreated. Balley Block, Block-Tops, John Boos, and Taylor Wood-Craft all manufacture butcher block counter tops.

ADVANTAGES: Natural wood butcher block may be more sanitary than synthetic surfaces.
DISADVANTAGES: Maintenance is critical to ensure the wood is sealed.

8. REPLACE WITH STAINLESS STEEL.

Stainless steel is heat proof and although not intended as a cutting surface, it will continue to perform with the scratches that occur with use. An 18 gauge stainless steel with either 8% or 10% nickel should be used to prevent staining, scratching, and corrosion. Counters are custom fabricated, and there are many design options such as integral sinks, drainboards, and backsplashes. Custom Copper and Brass, along with commercial kitchen product manufacturers, offer stainless steel countertops.

ADVANTAGES: Joints and welds are polished out for a seamless appearance.

DISADVANTAGES: Custom fabrication adds to cost of counter.

9. REPAIR OR REPLACE CONCRETE SURFACES.

Concrete counter tops are an emerging technology in the kitchen. Hot pots can occasionally be placed on the surface, but it is not recommended as the concrete may crack. Silicone sealers, acrylic topcoats, or butcher's wax will protect the porous surface from moisture and staining. Although small hairline cracks are characteristic of concrete counter tops, scratches and chips are not, and are a breeding ground for bacteria. Get Real Surfaces and Counter:culture from Soupcan fabricate concrete counters. Chips can be filled with concrete filler supplied by fabricator.

ADVANTAGES: Concrete counter tops can be tinted, and any fillers needed can also be tinted to match existing concrete color.

DISADVANTAGES: Sealant must be reapplied if cut or scraped, and cutting food on the surface is not recommended. Sealant must also be applied after repeated exposure to water, as is typical in a kitchen or bathroom.

FURTHER READING

"1999 Buyer's Guide," *Kitchen and Bath Business*, Feb. 1999.

"Annual Directory and Buyer's Guide," *Kitchen and Bath Design News*, Feb. 1999.

Bathrooms: How To, James A. Hufnagel, Hometime Video Publishing, Inc., 1998.

Bathroom Industry Technical Manual; Volume #3, Bathroom Equipment and Materials, Ellen Cheever, CKD, CBD, ASID, National Kitchen and Bath Association, 1997.

The Healthy Household, Lynn Marie Bower, Healthy House Institute, 1995.

Home Improvement for Dummies, Gene and Katie Hamilton, IDG Books Worldwide, 1998.

Kitchen Industry Technical Manual; Volume #3, Kitchen Equipment and Materials, Ellen Cheever CKD, CBD, ASID, National Kitchen and Bath Association, 1996.

"Repairing Stone Utilizing the Overfill Grind Technique," James Alseth, *Dimensional Stone*, August 18, 1998.

PRODUCT INFORMATION

Avonite, Inc., 1945 Hwy. 304 Belen, NM 87002; 800-428-6648; 505-864-7790 (fax); www.avonite.com.

Balley Block Co., 30 South 7th St., Balley, PA 19503; 215-845-7511.

Block-Tops, Inc., 4770 E. Wesley Dr., Anaheim, CA 92807; 714-779-0475; 714-779-2284 (fax).

Custom Copper and Brass, Inc., 420 Rt. 46 E., Fairfield, NJ 07001; 973-227-9334; 973-575-6499.

Dupont Corian, Barley Mill Plaza, PO Box 80012, Building 12, Wilmington, DE 19880; 800-426-7426; 302-992-2855 (fax); www.corian.com.

Formica Corp., 10155 Reading Rd., Cincinnati, OH 45241; 513-786-3261; 513-786-3024 (fax); www.formica.com.

Get Real Surfaces, 121 Washington Street, Poughkeepsie, NY 12601; 914-452-3988; 914-483-9580 (fax).

John Boos & Co. 315 S. 1st St. Effingham, IL 62401; 217-347-7701; 217-347-7705 (fax); www.effingham.net/johnboos/.

Marble Renewal, PO Box 56349, Little Rock, AR 72215; 501-663-2080; 501-663-2401 (fax).

Neveamar Int'l Paper, 8339 Telegraph Rd., Odenton, MD 2113; 800-638-4380; 410-551-0357 (fax); www.nevamar.com.

Pionite Decorative Surfaces, One Pionite Rd, Auburn, ME 04211; 800-746-6483; 207-748-9111; 207-784-0392 (fax); www.pionite.com.

Silestone, Cosentino USA, 3370 Mike Collins, Eagan, MN 55121; 800-291-1311; 651-406-9462; 651-406-9462 (fax); www.cosentino.usa.esSilestone.

Soupcan, Inc, Counter:culture Division, 1500 South Western Ave., Chicago, 60608; 312-243-6928; 312-243-6958 (fax); www.soupcan.com.

Taylor Wood-Craft, Inc. PO Box 245 Malta, OH 43758; 614-962-3741.

WilsonArt, International, Inc., 2400 Wilson Pl. Temple, TX 76504; 800-433-3222; 254-207-7000; 254-207-2545 (fax); www.wilsonart.com.

4.2

IMPROVE INDOOR AIR QUALITY

ESSENTIAL KNOWLEDGE

When particleboard is used as a substrate for laminate and solid surface counters, there is a threat of harmful emissions from the glue that binds the wood that forms the medium density fiberboard (MDF). Formaldehyde emissions are a hazard to indoor air quality, a suspected carcinogen, and the emissions cause skin irritations and asthma-like conditions in those with no previous symptoms.

TECHNIQUES, MATERIALS, TOOLS

The following are suggestions to reduce formaldehyde emissions:

1. REDUCE PARTICLEBOARD OUTGASING.

Store the particleboard outdoors or in an unoccupied storage building. Three months of outgasing is recommended before use. Good ventilation will reduce outgasing in installed cabinetry.

ADVANTAGES: Decreases outgasing once installed.

DISADVANTAGES: Adds time to fabrication; increases storage needs and expenses.

2. COVER ALL EDGES OF SUBSTRATE.

When storage of particleboard is not possible to outgas formaldehyde, a urethane, polyurethane sealant, or melamine laminate applied to the bottom, top, and edges of the particleboard will act as a barrier and reduce emissions. Seams should be sealed in existing counter tops.

ADVANTAGES: Sealed surfaces drastically limit emissions.

DISADVANTAGES: Adds material and labor expense to fabrication.

3. USE LOW OR NON-FORMALDEHYDE SUBSTRATE.

Most particleboard counter top substrates use a urea-formaldehyde. A healthier choice is a phenol formaldehyde-based particleboard. Another option is Medex, a formaldehyde-free particleboard, which uses a polyurea resin matrix to bond the MDF. Compared to standard MDF, Medex results in virtually no outgasing.

ADVANTAGES: Outgasing is low or non-existent; particleboard is machinable.

DISADVANTAGES: High cost.

FURTHER READING

The Healthy Household, Lynn Marie Bower, Healthy House Institute; 1995.

Prescriptions for a Healthy House, Paula Baker, AIA; Erica Elliot, MD; John Banta, InWord Press, 1998.

The Smart Kitchen, David Goldbeck, Ceras Press, 1994.

PRODUCT INFORMATION

SierraPine Ltd, Medite Division, Box 4040 Medland, OR 97501; 888- 633-7477; 916-772-3415; www.sierrapine.com.

4.3

IMPROVE BACKSPLASH AND COUNTER-TOP SEAMS

ESSENTIAL KNOWLEDGE

The backsplash, whether 4" high or full height between the counter top and the underside of the cabinet, is a shield to protect the walls surrounding sinks, cooktops, and work areas. However, seams between the backsplash and the counter top are susceptible to water, bacteria, and dirt build up. Maintenance is increased as a result. In climates with large swings in humidity levels, the situation is complicated by the seasonal swelling and shrinking of the material. Removing or covering these seams will eliminate areas for dirt to accumulate and bacteria to thrive.

TECHNIQUES, MATERIAL, TOOLS

Suggestions to improve or eliminate seams include:

1. FILL SEAMS IN LAMINATE COUNTER TOPS.

Products such as Kampel's SeamFil can be used to fill in gaps in laminate counter tops. They bond to the substrate, and when used with a retardant may be mixed to match surface color.

ADVANTAGES: Improves the appearance of any visible seams between sections of laminate, whether field joints or laminate seams. Helps to preserve counter top and reduce maintenance.

DISADVANTAGES: There may be a noticeable difference between filler and surface color or texture. Because this is fairly rigid, it cannot be used where the decks meet the backsplash.

2. FILL SEAM BETWEEN COUNTER TOP AND BACKSPLASH.

Although there are many caulks available, a 100% silicone caulk can be used to fill in the seams and resist water.

ADVANTAGES: Silicone caulk is durable and somewhat flexible; doesn't need replacement for long periods; minimizes exposure to toxins.

DISADVANTAGES: Caulk cannot be painted; colors are usually limited to clear, white, brown, and black.

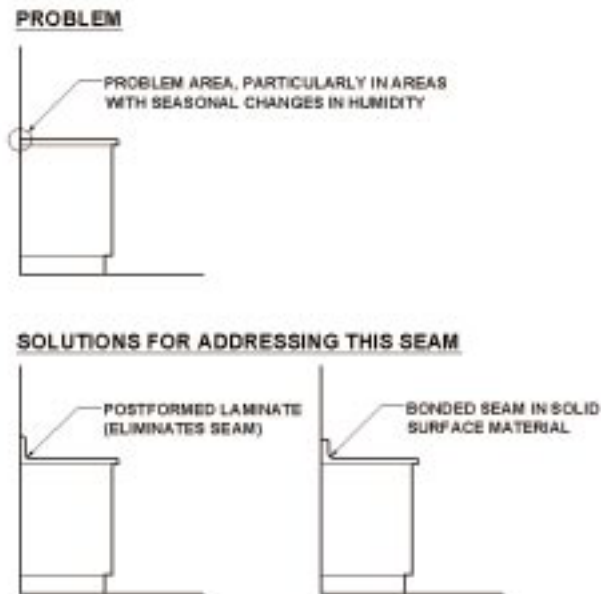

FIGURE 1

COUNTERTOP/BACKSPLASH SEAM DETAILS

3. INTEGRATE BACKSPLASH WITH COUNTER TOP.

Integral counter top and backsplash combinations available in solid surfaces and formed laminate have either an invisible bonded seam, where pieces of like material are chemically fused to make the seam nearly invisible, or no seam.

ADVANTAGES: Decreases maintenance; eliminates the critical joint where the counter meets the wall; improves sanitary conditions.

DISADVANTAGES: Reduces the possibilities for the use of any contrasting materials on the backsplash, but this can still be accomplished if the splash is not full height.

FURTHER READING

The Healthy Household, Lynn Marie Bower, Healthy House Institute, 1995.

Prescriptions for a Healthy House, Paula Baker, AIA; Erica Elliot, MD; John Banta, InWord Press, 1998.

PRODUCT INFORMATION

Kampel's Enterprise, Inc, Wellsville, PA 17365-0157; 800-778-7006; 717-432-9688; 717- 432-5601 (fax).

4.4

MAXIMIZE ACCESS AND FUNCTION

ESSENTIAL KNOWLEDGE

Because kitchen and bath counters and work surfaces are used for a variety of tasks by a variety of household members, universal design principles should be considered. Rehab is an opportunity to create flexibility in these areas so that different tasks can be performed safely and comfortably by users of differing age, stature, and abilities. To provide for this improved access, counter top space needs to be planned at a variety of heights within the recommended 30" to 45".

TECHNIQUES, MATERIALS, TOOLS

A few options to accommodate all users:

1. INSTALL COUNTERS WITH EASED OR BEVELED CORNERS.

Counter top corners should be rounded or beveled to eliminate a sharp 90 degree corner. When designing a beveled corner, the overhang must be sufficient to allow for the bevel (Fig. 2).

ADVANTAGES: Helps prevent minor injuries such as from bumping one's head or hip. May prolong useful life of the counter top.

DISADVANTAGES: Equal overhang dimensions look best, but may not be available.

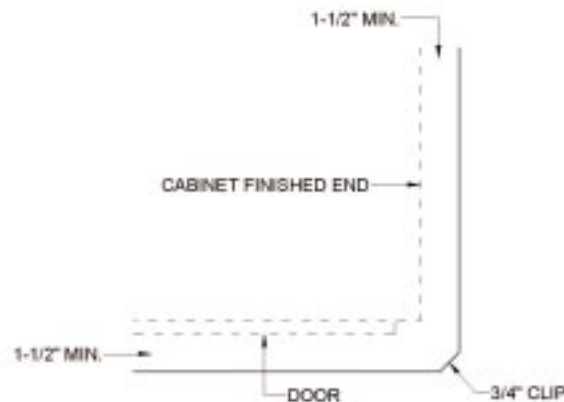

FIGURE 2

EASED AND CLIPPED COUNTERTOP CORNER

2. ADD DIFFERENT COUNTER HEIGHTS.

The shorter 30"-high base cabinet traditionally used for bathroom vanities is being replaced by a 34 1/2" cabinet, which is more practical and comfortable for face washing or shaving. The 30"-high cabinets can be used in the kitchen in an area dedicated to baking and preparation because the mixing action is more comfortable and efficient when the arms are extended. This height also suits a seated user. In addition to the traditional 40 1/2" stub wall constructed to support a dining counter, a 42"-high counter can be supported by raising the dishwasher, single oven, or microwave.

ADVANTAGES: Various heights allow for different work areas throughout the kitchen.

DISADVANTAGES: Some cabinetry may have to be replaced and half walls may have to be constructed to vary the counter top heights. In a kitchen with minimal counter surface, this reduced continuous work surface may be inconvenient.

3. INSTALL ADJUSTABLE HEIGHT COUNTER.

A 36" to 48"-wide counter can be adjusted 8" vertically with the use of a motorized system, such as those available from Accessible Designs Adjustable Systems or Auton, to allow height adjustment at the touch of a button. Another system from Hafele provides the same adjustment in height via a crank system. Specifically for the bath, systems are available that allow the sink to adjust in height.

ADVANTAGES: The unit plugs into a ground fault circuit interrupter (GFCI) outlet, and the counter top adjusts to a height comfortable for a baking center, desk area, or for users of different heights.

DISADVANTAGES: No cabinet space is available below the counter top.



FIGURE 3

ADAS ADJUSTABLE HEIGHT COUNTER

FURTHER READING

Universal Kitchen and Bath Planning, Mary Jo Peterson, CKD, CBD, CHE, McGraw-Hill, 1998.

PRODUCT INFORMATION

Auton Motorized Systems, PO Box 802320 Velencia, CA 91380; 805- 257-9282; 805-295-5638 (fax); www.auton.com.

Accessible Designs Adjustable Systems, ADAS, 94 North Columbus Road, Athens, OH 45701, 740-593-5240; 740-593-7155 (fax).

Hafele, PO Box 4000, 3901 Cheyenne Drive, Archdale, NC 20263; 919-889-2322; 800-423-3531; 910-431-3831 (fax); www.hafeleus.com.

Pressalit, 6615 West Boston Street, Chandler, AZ 85226; 480-961-5353; 480-961-8787 (fax).

IMPROVING FUNCTIONAL COUNTERTOP SPACE

ESSENTIAL KNOWLEDGE

In most kitchens, countertop space is minimal. It is sometimes believed that a work surface on either side of the sink is sufficient. However, counter surfaces should be available for use as a landing for items removed from the cooktop, oven, microwave, refrigerator, and dishwasher. By planning additional and flexible counter space, food preparation, serving, dining, and dish cleaning areas can be created in a rehabbed kitchen without adding space, and the function of the space is improved.

TECHNIQUES, MATERIALS, TOOLS

Options to make more functional countertop space include:

1. INSTALL SMALL APPLIANCES UNDER WALL CABINETS.

Small appliances clutter the counter and minimize the work surface. Installing under-cabinet appliances at their point of use will also improve function. For example, under-cabinet microwaves are available with a hanging kit to suspend the oven from the bottom of a wall cabinet. A metal bracket is screwed to the bottom of the wall cabinet, and the oven is bolted to the bracket in pre-drilled locations.

ADVANTAGES: By removing the appliances from the counter top, a full depth, unobstructed, and continuous work space is created.

DISADVANTAGES: Appliances may be at a new height that is not accessible to all users.

2. INSTALL A PULL-OUT WORK SURFACE.

A standard drawer can be replaced with a pull-out table. Drawer fronts are screwed directly to the table trim panel and accompanying hardware. The unit is not visible when installed. The Hafele pull-out table unit (Fig. 4) is self-supporting and has a load capacity of 220 pounds.

ADVANTAGES: Additional work space can be added when needed, and the table can be closed when not in use.

DISADVANTAGES: Eliminates drawer space; requires a minimum drawer width of 23 5/8”.



FIGURE 4

HAFELE PULL-OUT WORK SURFACE

3. INSTALL A HEAT-RESISTANT COUNTER MATERIAL

Small sections of heat-resistant surfaces such as stainless steel, ceramic tile, and stone can be installed adjacent to the cooking or dining area.

ADVANTAGES: Surface can be used as a landing space for hot items, and the surface adds a contemporary interest to countertop.

DISADVANTAGES: There will be a seam where two different surfaces join.

4. INSTALL A ROLLING TABLE OR CART

Castors and a counter top can be attached to any existing shelf unit. A cart can be constructed with a base cabinet door and drawer front so it will fit in the base space when not in use. The table will act as a mobile island with additional counter top space and storage below. The table can be placed below the oven to provide a close landing surface for hot food.

ADVANTAGES: A rolling table improves flexibility and increases counter space.

DISADVANTAGES: Compromises or limits drawer and base cabinet storage.

FURTHER READING

Installation of Ceramic and Stone Tiles, and Dimension Stone Countertops, Jess McIlvain, AIA, CCS, CSI, and Joe Ranzoni, National Kitchen and Bath Association, 1997.

PRODUCT INFORMATION

Household Appliances, Inc., (formerly Black and Decker Household Appliances); 6 Armstrong Rd. Shelton, CT 06484; 800-231-9786; www.blackanddecker.com.

Hafele, PO Box 4000, 3901 Cheyenne Drive, Archdale, NC 20263; 919-889-2322; 800-423-3531; 910-431-3831 (fax); www.hafeleus.com.

4.6

ENHANCE BACKSPLASH WITH SURFACE MATERIALS

ESSENTIAL KNOWLEDGE

Sometimes a rehab kitchen or bath project can be greatly improved in appearance with the addition of countertop and backsplash surface materials. Surfaces not advised for countertop use (such as metallic laminate, marble, or decorative tiles), or too costly to use throughout the entire countertop and backsplash (such as stainless steel, wood, or granite), can be used in the backsplash only. Because of the vertical plane of the backsplash, surface materials on the backsplash are more visible than the horizontal countertop plane and can easily become a focal point. To further maximize visibility, the backsplash can extend to the underside of the cabinet above it, rather than the typical 4" high backsplash.

TECHNIQUES, MATERIALS, TOOLS

Options to visually improve the backsplash:

1. INSTALL METALLIC LAMINATE BACKSPLASH.

Metallic laminates are applied with adhesive and heat in the same fashion as plastic laminate. Applying the laminate to a 1/4" or 1/2" substrate will decrease any risk of problems at the seam where the counter meets the splash. Abet Laminati, Lamin-Art, WilsonArt's Artisan Group, and Formica's DecoMetal collec-

tions offer a variety of colors and textures to choose from.

ADVANTAGES: Less expensive than metallic tiles or solid metal sheets.

DISADVANTAGES: Limited color and textures to choose from; higher cost than plastic laminates.

2. INSTALL DECORATIVE CERAMIC TILE BACKSPLASH.

Decorative wall tiles come in a wide variety of colors, textures, sizes, and shapes, and can be used in combination with the field tile to distinguish and outline separate work areas along the backsplash. Decorative tile can be used to create a motif or accent a space. Crossville manufactures a variety of metallic tiles.

ADVANTAGES: White or light-colored grout can be used on the backsplash because it will not be stained, unlike grout used on floors and countertops.

DISADVANTAGES: Large tiles may require additional time to install, and grout may need sealing and minor maintenance during the life of the tile.

3. INSTALL STONE BACKSPLASH.

Granite, soapstone, slate, and even marble can be used in the backsplash. Because marble is soft and porous, it is not recommended for heavy countertop use, but it can be used on the backsplash. While some stone is available only in slab, most marble is also available in tiles. For optimum results, outlets and switches should be moved (unless this results in impractical access) to provide an uninterrupted backsplash. Typically, plug molding is installed at the top of the splash or receptacles are installed at drawer height under the counter.

ADVANTAGES: Adds the visual impact of stone without the high cost of solid stone counters.

DISADVANTAGES: Stone splash material is higher in cost than most other options and it will require sealing and maintenance similar to tile.

4. INSTALL OTHER MATERIALS.

A wood or mirrored surface can be used on the backsplash for visual impact. A beadboard panel complements the existing cabinetry and can be purchased locally. A mirror can be cut and installed by a glass supplier.

ADVANTAGES: Can brighten, enlarge, and otherwise enhance the existing space.

DISADVANTAGES: Can be difficult to remove water spots; some high end materials can be costly.

PRODUCT INFORMATION

Abet Laminati, 60 Sheffield Ave., Engelwood, NJ 07631; 800-228-2238; 201-541-0700; 201-541-0701 (fax).

Crossville, P.O. Box 1168, Crossville, TN 38557; 615-484-2110; 615-484-8418 (fax); www.crossville-ceramics.com.

Formica Corp., 10155 Reading Rd., Cincinnati, OH 45241; 513-786-3261; 513-786-3024 (fax); www.formica.com.

Lamin-Art, 1330 Mark St., Elk Grove, IL 60007; 800-526-4627; 847-860-0180 (fax); www.laminart.com.

WilsonArt, International, Inc., 2400 Wilson Pl. Temple, TX 76504; 800-433-3222; 254-207-7000; 254-207-2545 (fax); www.wilsonart.com.

5

APPLIANCES

5.1

REPLACE OUTDATED OR NON-FUNCTIONING APPLIANCES

ESSENTIAL KNOWLEDGE

When a kitchen appliance is non-functioning, the solution may be as simple as repair by an authorized service person, and refinishing to update the appearance. More often, the problem will be better solved by replacing the appliance because it no longer meets the family's needs or its performance and energy use are inferior to those of newer models. Energy Star ratings from the U.S. Department of Energy and the Environmental Protection Agency list, by brand, the most energy-efficient appliances. Impact on the overall kitchen space must be determined by examining the existing appliances and the space in which they had been installed, and whether or not they are structurally connected to the surrounding space. Once the space available for the new appliance has been determined, a new model can be selected. This process can be facilitated by information available on the web sites of most of the major manufacturers. This is also an opportunity to improve access to the appliance and surrounding work areas, and to change the layout of the entire space.

TECHNIQUES, MATERIALS, TOOLS

1. REPLACE REFRIGERATOR.

Refrigerators with inaccurate temperature control, broken bins and racks, and irreparable damage to the door gaskets should be replaced. In the recent past, refrigerators have undergone major changes in design and technology to improve function and save energy. Current models include free standing 30" deep cases, built-in style free-standing 24" deep cases, and fully integrated styles that must be built into walls or cabinetry. A new refrigerator should last about 15 years.

ADVANTAGES: Current models can result in energy savings that over time will recover the added cost of the appliance. Convenience can be greatly enhanced.

DISADVANTAGES: Changes in width, height, and style of the refrigerator can force adjustments in surrounding cabinetry, counters, and walls. Changes in depth can require rehabing the flooring. Energy Star appliances may be higher in cost.

2. REPLACE RANGE.

Ranges with burners that won't heat, ignition malfunction, lack of temperature control, and non-operating self-cleaning features should be replaced. Older gas ranges with pilot lights waste energy and degrade indoor air quality. Although there are various sizes, most models are available in the standard 30" width. A review of desired performance will assist in selection. The desired power source, whether gas (liquid propane or natural) or electric, must be accommodated and the conversion made if necessary. There are three main types of ranges available: free-standing, slide-in, or drop-in. If the existing range is free-standing, replacement is straight forward. Slide-in or drop-in ranges will require a close examination of the new range for proper fit. Commercial style free-standing ranges have increased power and heat, and require attention to ventilation requirements. Consult manufacturer for exact specifications. A new range should last about 15 years.

ADVANTAGES: Improved performance, added safety features, and aesthetics.

DISADVANTAGES: May require adjustments to surrounding cabinetry, counters, and ventilation.

3. REPLACE COOKTOP.

Cooktops with burners that won't heat, ignition malfunction, downdraft ventilation mechanical difficulties, and damaged surface should be replaced. Similar to a range, the power source must be determined before a new cooktop can be selected. Three general types of electric cooktops available are conventional coil elements, cast-iron solid disk elements, and glass ceramic cooktops, with induction and halogen technologies used with glass ceramic cooking surfaces. Cooktop sizes and cutouts vary tremendously and must be determined for proper fit in the existing counter. Consult the manufacturer for exact specs. A new cooktop should last about 15 years.

ADVANTAGES: Variety of styles and features available; improved aesthetics. This may be an opportunity to improve access to the cooking area.

DISADVANTAGES: May require reworking or replacing counter and cabinet.

4. REPLACE OR ADD A RANGE VENTILATION SYSTEM.

The kitchen produces significant indoor air pollution with water vapor, grease, smoke, and odors, and a ventilation system that does not remove pollution from the kitchen should be replaced. The exhaust rate of the fan (cubic feet per minute) must be adequate to accommodate today's cooking systems. As a minimum, a 0.1 multiplier of the range's BTU rating should be used to determine the cfm. For example, a professional gas cooktop with a 900 BTU rating should have a hood exhaust system equal to, or greater than, 90 cfm. In all cases, the manufacturer's specifications regarding CFMs should be met as a minimum. A recirculating vent with a carbon filter only filters the pollution and reintroduces it back into the room. Such systems should be replaced with a ventilation system that exhausts to the outside. Hood systems, microwaves with built-in ventilation, and proximity or downdraft systems are ventilation options; the system selected depends on the kitchen arrangement, fan noise, and cooking load. Microwaves with built-in ventilation placed above the cooking surface are not accessible or safe for all users and do not comply with universal design guidelines.

ADVANTAGES: Grease and smoke particles will not accumulate on finishes when adequate ventilation is used.

DISADVANTAGES: Make-up air may be needed to avoid negative air pressure.

5. REPLACE A WALL OVEN.

Though energy usage is not affected when a separate oven and cooktop are used, individual units are usually more costly. Similar to the cooktop, the energy source and cutout size of a wall oven are critical to successful replacement; both gas and electric ovens have grown in size from 24" to 27" and recently, 30" widths. If a change of energy source is desired, a rehab project is the time to switch from either gas or electric because gas pipes, vents, and electrical connections may restrict the design. Gas ovens are heated by a burner below the oven floor, and utilize convection and radiation heating methods. For energy savings, gas ovens with an electronic ignition should replace those with a continuously burning pilot light. Placement of the heating units within electric ovens is usually on the floor and ceiling of the oven chamber. The use of convection heat in electric ovens is preferable because convection ovens offer even baking in less time and with less energy. Convection heat is created when an element heats the air and a fan circulates the air evenly throughout the oven. For energy source and cut-out size information, consult manufacturers' specs.

ADVANTAGES: Improved performance; safety lockout available.

DISADVANTAGES: New ovens rarely fit the existing cutout and require some amount of redesign of the space.

6. REPLACE MICROWAVE.

Microwave ovens that spark or cycle while the door is open should be replaced. If a microwave is built in or combined with a convection oven in a single unit, replacement can be treated as a wall oven (see above, REPLACE A WALL OVEN). If the microwave is free-standing, replacement is straight forward. Consider the option of selecting a microwave that can be hung from a wall cabinet to clear counter space.

ADVANTAGES: Newer models are smaller and have added features.

DISADVANTAGES: Built-in microwaves will require coordination with the surrounding cabinetry or walls.

7. REPLACE DISHWASHER.

Dishwashers with motor failure and excessive water leakage, noise, and water usage should be replaced. American manufactured dishwashers are typically designed to fit into a space 24" wide, so replacement is fairly straight forward. If the finish floor has been installed after the dishwasher and the floor height is greater, it may be difficult to remove the old dishwasher and install the new one. European dishwashers are gaining in popularity because of their water-saving features and they are often slightly narrower than the American models. In either case, front panels to match existing cabinetry vary in size. Again, check the manufacturers' specs. When redesign is necessary or possible, consider raising the dishwasher to a 42" height to improve access. A new dishwasher should last about 12 years.

ADVANTAGES: Energy and water conservation, performance, reduced noise, access.

DISADVANTAGES: New dishwasher may create problems with flooring, custom front panels, and adjacent cabinetry. Energy Star appliances may be higher in cost.

8. REPLACE FOOD WASTE DISPOSER.

Feeding garbage too quickly into a waste disposer or failing to run enough cold water to completely flush drainpipes during processing can result in a clogged system. Old disposers are subject to rusting and motor burn-out. Motor size, insulation, and anti-jam features differ from model to model. Continuous feed and batch feed options are available. Continuous feed operates continuously from a switch, typically a toggle switch located on the wall, and batch feed disposals operate when the lid is turned. New to the market, In-Sink-Erator offers a disposer designed for use with a septic system.

ADVANTAGES: Includes features that meet user's needs and practices.

DISADVANTAGES: If home uses a septic system, local codes may not allow disposer; some septic systems may need to be enlarged and cleaned more often if a disposal is used.

FURTHER READING

"1999 Buyer's Guide," *Kitchen and Bath Business*, Feb. 1999.

"Annual Directory and Buyer's Guide," *Kitchen and Bath Design News*, Feb. 1999.

Builder Appliances, www.builderappliances.com

Kitchen Industry Technical Manual; Volume #3, Kitchen Equipment and Materials, Ellen Cheever, CKD, CBD, ASID, National Kitchen and Bath Association, 1996.

"Kitchens; A Smorgasbord of Energy Savings," Bruce Sullivan, *Home Energy Magazine*, Reprint.

No Regrets Remodeling, Energy Auditor & Retrofitter, Inc., 1997.

The Smart Kitchen, David Goldbeck, Ceres Press, 1994.

"Repair or Replace; Weighing the Options," Allison Murray Moris, *Women's Day, Kitchens and Bath Special Interest Publication*, Winter 1998, p. 22.

PRODUCT INFORMATION

U.S. Environmental Protection Agency ENERGY STAR Program, 401 M Street, SW (6202J) Washington, D.C. 20460; 888-STAR-YES (782-7937); www.energystar.gov.

In-Sink-Erator, 4700 21st Street, Racine, WI 53406; 800-558-5712; 414-554-3534; 414-554-3639 (fax); www.insinkerator.com.

5.2

IMPROVE ACCESS AND FUNCTION WITHIN WORK CENTERS

ESSENTIAL KNOWLEDGE

The work triangle is the main working area of the kitchen, and it is created by the work flow between the work centers of the cooktop, the sink, and the refrigerator. The National Kitchen and Bath Association guidelines suggest that the work triangle should not exceed 26 lineal feet, with no leg being less than 4' or more than 9'. Relocating the appliances within the work triangle or creating a secondary work triangle can maximize efficiency and function of the space. Food preparation begins with the refrigerator, moves to the preparation area between sink and refrigerator, and on to the mixing area between the sink and the cooktop. The last steps occur in the serving area from cooktop to the table. Clean up occurs from the table to the dishwasher, and from there to storage. Rehab work in kitchens should consider this arrangement, and new appliance layouts should be designed to better facilitate use. Today's kitchens often include more than one cook and a variety of activities at the same time. To accommodate this, duplicates of certain appliances, such as cooktop, oven, or dishwasher, can be desirable.

TECHNIQUES, MATERIALS, TOOLS

Suggested locations and placement of appliances:

1. CONSIDER REFRIGERATOR LOCATION AND RELOCATE IF NECESSARY.

The refrigerator is often placed at the end of a cabinetry run or on a separate wall because it should not interrupt a continuous work counter. However, the landing space needed in front of or adjacent to the refrigerator is often eliminated, causing inconvenience when opening the refrigerator door. A landing counter with a 15" minimum width is needed on the freezer side of a side-by-side style, on the handle side of a top-mount or bottom-mount style, or directly across from either model on an island. Return walls that extend farther than the depth of the refrigerator case intrude into the required clear floor space and can limit the door swing. Maintaining return walls no greater than the depth of the refrigerator will allow a full

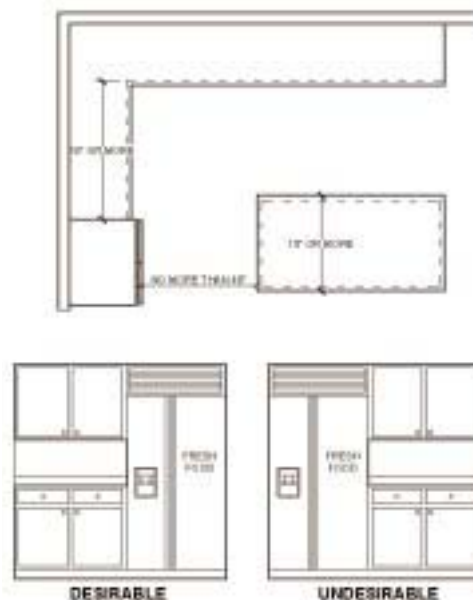

FIGURE 1

REFRIGERATOR DOOR SWING TO OPEN TOWARDS COUNTER

door swing. Adding another refrigerator station such as an under-counter refrigerator or beverage chiller in the secondary work triangle allows for multiple cooks in the kitchen. Refrigerator and freezer drawers from Sub-Zero permit greater flexibility and easier access.

ADVANTAGES: Improves function; second appliance can increase work stations without eliminating work counter surface.

DISADVANTAGES: May require greater change than rehab justifies; cost may be considerable with a second appliance. Some base cabinet storage sacrificed.

2. CONSIDER COOKTOP AND SEPARATE OVEN RATHER THAN RANGE.

When a kitchen is used by more than one cook, the range can become crowded and it can be difficult to transfer hot items from the oven to the nearest landing space. Separating the cooktop and oven improves flexibility in the kitchen and can improve landing and work space surrounding each appliance. Because the oven is the least used appliance in the kitchen, it is acceptable to place it outside the concentrated working area of the kitchen.

ADVANTAGES: Can greatly improve use and access.

DISADVANTAGES: More costly to separate these two appliances than simple replacement.

3. CONSIDER COOKTOP LOCATION AND RELOCATE IF NECESSARY.

A safety concern in many existing homes is the lack of counter space surrounding the cooktop burners. A landing space of 15" is needed on at least one side of the cooktop. To maintain a safe distance from the burners and pot handles, at least 9" of open counter space or 3" to a heat-proof wall is needed on the other side of the landing space. Cooktops placed on islands should have 9" of clearance or a change in height on the back side of the island for safety. The cooktop should be relocated, the counter extended, or a wall constructed to maintain the required distance on either side of the cooktop. The cooktop and adjacent counter may be installed at a height other than the standard 36"; a height between 30" and 34" above the floor improves access for most cooks. Maintaining open space or flexible storage below the cooktop allows the option to sit while cooking.

ADVANTAGES: Greatly improves use and access.

DISADVANTAGES: Safety considerations may eliminate the option of a cooktop on a small island.

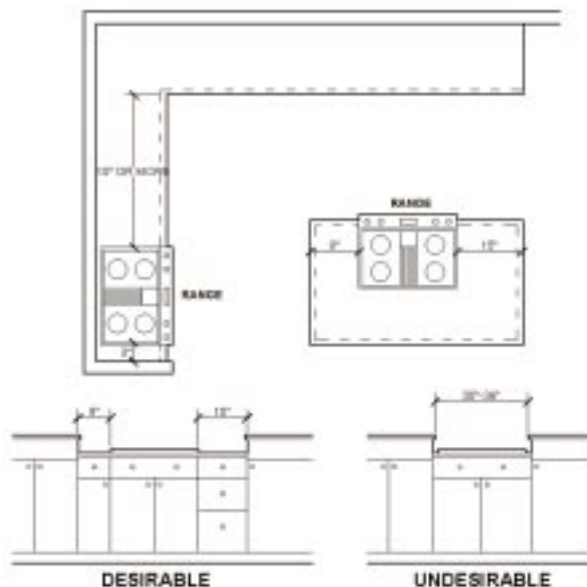

FIGURE 2

REQUIRED LANDING COUNTER CLEARANCES FOR COOKTOP AND RANGE

4. CONSIDER OPTIONAL OVEN PLACEMENT.

A tall cabinet that houses double ovens is a remedy to ease congestion in the kitchen work area. However, this results in oven placement at a difficult height. A better solution is to install one oven with the bottom +/- 24" above the finished floor, a comfortable distance between the universal reach range of 15" to 48". An oven with a side swing door, installed at +/-30", and a pull-out landing surface directly below the oven door is another alternative. A third option is to raise the height of the base cabinet housing the oven to 40 1/2" above the floor. This allows for a possible drawer below and it creates a standard snack-bar height of 42".

ADVANTAGES: Greatly improves use and access.

DISADVANTAGES: Existing kitchen may have space restraints.

5. CONSIDER MICROWAVE LOCATION AND RELOCATE IF NECESSARY.

Microwaves are often an afterthought in kitchen design, resulting in a less-than-desirable space for this popular appliance. Although the height of the standard 36" high countertop is ideal for most sizes, ages, and abilities, locating the microwave on the counter eliminates valuable work space. If the depth of the microwave leaves a counter space of less than 16", a pull-out shelf or rollout cart directly below can be used. The ideal location for access is to mount the unit so that its bottom is 24" to 48" above the floor. Built-in styles can be installed in a base cabinet, 40 1/2" high (under a 42" snack bar), to reduce bending. They can also be placed above a single oven in a tall cabinet or on a shelf below a wall cabinet, depending on depth. Smaller compact styles can be hung from wall cabinets, installed above a raised dishwasher or oven, or hung from a 42" dining counter above a table. The best location for the microwave in the main kitchen area for food preparation tasks is between the sink and the refrigerator. However, the role of the microwave in the kitchen has expanded and multiple users can result in waiting and congestion in front of the microwave in the main preparation area. The addition of a second microwave provides for simultaneous food preparation when one unit is placed in the work triangle and the other outside of it.

ADVANTAGES: Improves access, efficiency, and safety. Cost of additional microwave is reasonable.

DISADVANTAGES: The size of the microwave should be based on the intended use. Lack of space in the kitchen may limit size of second microwave.



FIGURE 3

UNDER-CABINET MICROWAVE WITH HANGING KIT

6. CONSIDER DISHWASHER LOCATION AND RELOCATE IF NECESSARY.

The traditional dishwasher location is beneath the standard 36" high counter, which requires a standing user to bend to access the bottom rack. Mounting the dishwasher 6" to 9" above the floor puts the racks within the 15" to 48" universal reach range to improve comfort. The dishwasher does not need to be immediately adjacent to the sink. National Kitchen and Bath Association guidelines suggest the dishwasher

be no farther than 36" from the edge of the sink. This will provide continuous work counters of 12" and 24" on either side of the sink when the dishwasher is raised to a different counter height. Often a dishwasher is placed so it can be used by only one person at a time, and there should be 21" clear floor space on either side of the dishwasher when another appliance, cabinet, or counter is at a right angle to it to allow access from either side. Adding a second dishwasher in the butler's pantry or near dining improves function. Dishwasher drawers, such as those from Fisher & Paykel, allow for maximum flexibility.

ADVANTAGES: Greatly improves use and access.

DISADVANTAGES: Counter space surrounding sink may not be sufficient to raise dishwasher. Installing a new dishwasher may require new patterns for loading dishes.



Photo: CE

FIGURE 4

DISHWASHER RAISED TO 42"

FURTHER READING

Kitchen Industry Technical Manual; Volume #3, Kitchen Equipment and Materials, Ellen Cheever, CKD, CBD, ASID, National Kitchen and Bath Association, 1996.

Kitchen Industry Technical Manual; Volume #4, Kitchen Planning Standards and Safety Criteria, Ellen Cheever, CKD CBD ASID, National Kitchen and Bath Association, 1996.

ProMatura Enabling Products Sourcebook 2, Margaret A. Wylde, Ph.D.; Deany Hillhouse; Joe Austin; Kristen Suslar Guinn, National Kitchen and Bath Association, 1995.

Universal Kitchen and Bath Planning, Mary Jo Peterson, CKD, CBD, CHE, McGraw-Hill, 1998.

PRODUCT INFORMATION

Frigidaire Home Products, 6000 Perimeter Dr., Dublin, OH 43017; 614-792-4100; 614-792-4073 (fax); www.frigidaire.com.

Fisher & Paykel Appliances Inc., 22982 Alcade Dr. #201, Laguna Hills, CA 92653; 888-936-7872; 949-829-8865; 949-829-8699 (fax); www.fisherpaykel.com.

GE Appliances, Appliance Park Louisville, KY 40225; 800-626-2000; 440-962-2770 (fax); www.ge.com/appliance.

Refrigerator Drawers, Sub-Zero Freezer Co., Inc., 4717 Hammersley Rd., Madison, WI 53711; 800-444-7820; 608-270-3273; 608-270-3339; www.subzero.com.

5.3

UPGRADE APPLIANCE APPEARANCE

ESSENTIAL KNOWLEDGE

Many older appliances show their age because of an outdated color, or scratches on the visible sides and edges. In many rehab projects the appliances may function well, but should be refurbished or better coordinated to the updated kitchen if they are to remain.

TECHNIQUES, MATERIALS, TOOLS

Techniques to improve exterior of appliances:

1. PAINT APPLIANCE EXTERIOR.

Specialty-paint or automobile-paint stores may be able to recommend paint for an appliance exterior. The surface must be clean and free of oils; otherwise, the newly applied paint may fade, peel, or crack. The unit should also be empty and unplugged before it is painted, and the paint should be applied in thin coats. If a more uniform surface is desired, a professional should be contacted to apply the paint.

ADVANTAGES: Updates older appliances.

DISADVANTAGES: Interiors may not match exterior; appliance life will be shorter than the rest of the kitchen. Labor intensive.

2. INSTALL PANELS.

Trim kits for many older model dishwashers and refrigerators may still be available. Call the appliance manufacturer with the model and serial numbers to obtain the trim kit model number. A custom look is achieved with wood or laminate panels that match the cabinetry and can be ordered through a cabinet supplier. Caution should be used to maintain a comfortable grip at the handle if choosing a thick raised panel.

ADVANTAGES: Updates an older, functional appliance.

DISADVANTAGES: Does not take advantage of improved energy efficiency available in new models. Sometimes difficult to match existing cabinet finishes.

3. CREATE A BUILT-IN LOOK FOR THE REFRIGERATOR.

The average freestanding refrigerator case is 30" deep, which means 6" extends past the cabinetry into the work aisle (refer to user's manual to determine the coil and compressor location and air space needed for ventilation surrounding the unit). Pulling forward and blocking the surrounding base and wall cabinets 4" to 6" will create a 30" deep countertop flush with the refrigerator case. The deep counter is an ideal work space situation for small appliance storage. End panels surrounding the refrigerator are extended to 30" deep to house the refrigerator.

ADVANTAGES: Adds work space, improves appearance.

DISADVANTAGES: Requires new adjacent counter for added depth. Should not block air circulation.

4. RECESS REFRIGERATOR.

A refrigerator can sometimes be recessed into a partition wall, a closet wall, or a garage wall behind it. The wall should not be load-bearing. The sheetrock or plaster is removed and the area surrounding the unit is framed. The depth of the recess can be determined by the allotted space needed to make the refrigerator flush with the cabinets (usually 4" to 6") and a plywood backer is then screwed to the sheetrock. The recess should not be deeper than the case. Alcove walls can be built on both sides of the refrigerator with 2x4 studs and sheetrock. Mounting the electrical outlet above the back of the refrigerator eliminates space lost from a plug directly behind it. The adjacent counters should be clipped so that the refrigerator doors can swing fully open.

ADVANTAGES: Refrigerator will be nearly flush with adjacent cabinetry.
DISADVANTAGES: Will increase sound penetration from the kitchen to the next room. Can reduce air circulation to refrigerator's rear cooling coil. If a garage wall is used, fire codes may prohibit this option.

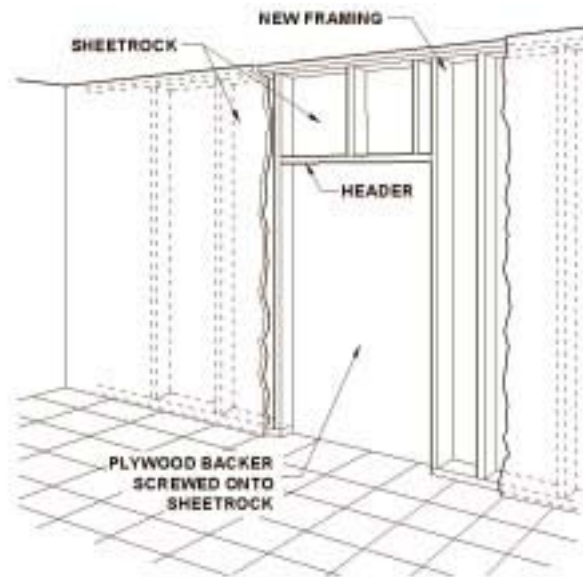

FIGURE 5

NEW FRAMING TO RECESS REFRIGERATOR INTO WALL

FURTHER READING

“Thinking Creatively About Appliances,” James Kregel, CKD, CBD, IIDA, *Kitchens By Professional Designers*, Book IX, p.24-29.

5.4

IMPROVE RESOURCE AND ENERGY EFFICIENCY OF EXISTING APPLIANCES

ESSENTIAL KNOWLEDGE

According to *Home Energy Magazine*, the kitchen consumes 20% to 40% of a household's energy. Therefore, small changes in the location and adjacencies of existing appliances can result in reducing electric and gas bills.

TECHNIQUES, MATERIALS, TOOLS

Suggestions to improve appliance energy efficiency:

1. CONSIDER APPLIANCE ADJACENCIES AND AIR TEMPERATURE.

A refrigerator placed in direct sunlight will have to work harder to maintain its interior temperature. Higher air temperature and humidity in the room will also force the compressor to use more energy. When the refrigerator is placed next to a high temperature appliance such as the cooktop, oven, or dishwasher, the compressor must work harder to maintain the refrigerator temperature. The layout of the kitchen can be redesigned to separate the appliances, or a barrier of 3" fiberglass or 1" foil-faced insulation between the refrigerator and the hot appliance will improve efficiency.

ADVANTAGES: Improves efficiency and energy performance.

DISADVANTAGES: May require redesign for needed additional space.

2. PROVIDE VENTILATION AND CIRCULATION.

Often, appliances are "suffocated" because a built-in look is incorrectly executed. Consult manufactures' specs and, particularly in the case of true built-in appliances, follow them carefully. Consider options for additional circulation by creating openings behind the cabinetry above the appliance. Freestanding refrigerators require space surrounding the unit so heat from the condensing coil and compressor can escape. The coils should be cleaned twice a year to remove cooking grease, dust, and lint. To maximize efficiency, some sources recommend doubling the manufacturer's specified clearance for refrigerator installation.

ADVANTAGES: Improves efficiency and energy performance.

DISADVANTAGES: Requires more room dedicated to free space around the appliances.

3. PROVIDE ADEQUATE VENTILATION TO EXTERIOR.

Clothes that do not dry in a timely manner may be an indication that a dryer is not running properly. When the dryer is connected to a long run of duct work, the warm moist air is not exhausted as intended, and the dryer interior remains moist and uses more time and energy to dry clothes. Fantech offers an inline fan (Fig. 6) that compensates for the duct system length by boosting the air flow to the exterior.

ADVANTAGES: Improves efficiency and energy performance.

DISADVANTAGES: System must be accessible.



FIGURE 6

FANTECH DRYER BOOSTER

FURTHER INFORMATION

“Kitchens; A Smorgasbord of Energy Savings,” Bruce Sullivan, *Home Energy Magazine*, Reprint.

No Regrets Remodeling, Energy Auditor & Retrofitter, Inc., 1997.

Prescriptions for a Healthy House, Paula Baker, AIA; Erica Elliot, MD; John Banta, InWord Press, 1998.

The Smart Kitchen, David Goldbeck, Ceres Press, 1994.

“Thinking Creatively About Appliances,” James Krengel, CKD, CBD, IIDA, *Kitchens by Professional Designers*, Book IX, p. 24-29.

PRODUCT INFORMATION

Fantech, Inc., 1712 Northgate Blvd., Sarasota, FL 34234; 800-747-1762; 941-351-2947; 941-359-3828; www.fantech-us.com.

U.S. Environmental Protection Agency ENERGY STAR® Program, 401 M. Street SW (6202J) Washington, D.C. 20460; 888-STAR-YES (782-7937); www.energystar.gov.

5.5

INSTALL RESOURCE AND ENERGY-EFFICIENT APPLIANCES

ESSENTIAL KNOWLEDGE

Outdated appliances are often oversized for their limited technology and, compared to today’s efficient models, they consume more gas, electricity, or water. This combination often means that more space must be dedicated to older appliances whose performance is poor. One must consider the long-term, life-cycle cost and energy savings. The ENERGY STAR® rating and Energy Guide compare the initial cost and lifetime operating costs. The Energy Star rating lists and rates only selected high efficiency refrigerators, dishwashers, clothes washers, water heaters, and heating and cooling equipment, and the Energy Guide compares the initial cost and the lifetime operating costs of all similar appliance models.

TECHNIQUES, MATERIALS, TOOLS

Energy-saving features to look for in new appliances:

1. CONSIDER REPLACING THE REFRIGERATOR.

The refrigerator consumes more energy than any other kitchen appliance, and care should be taken to choose an energy efficient model. The Energy Guide compares the initial cost and long term energy savings to other similar models with the same features, style, and capacity, and when energy-efficiency is a priority over all other considerations, the ENERGY STAR® rating should be used. Although larger refrigerators are more energy efficient, they still require more energy to operate and they take up more space. A top- or bottom-mount refrigerator is more efficient than a side-by-side refrigerator. Refrigerators with additional conveniences, such as ice makers, water dispensers, and automatic defrost, improve function but consume more energy. Northland manufactures a custom refrigerator with glass doors to allow the contents of the refrigerator to be viewed without opening the doors.

ADVANTAGES: Cost can be offset by local power company credits, long term savings.

DISADVANTAGES: Higher initial cost. Not all models from a manufacturer will have an ENERGY STAR® rating.

2. CONSIDER REPLACING THE DISHWASHER.

The cost of running a dishwasher is incurred mostly from heating the water. When selecting a new dishwasher, consider features to reduce the amount of hot water used. For dishwashers to clean properly, 140°F is the recommended water temperature. The cost of running a dishwasher is increased because the domestic hot water heater is set to 140°F, although no other fixtures in the house require water hotter than 120°F. An integrated water booster provides the 140°F temperature for dishwashing without over-heating the domestic water supply, and the whole-house water heater can then be set to 120°F. To keep the interior of the dishwasher clean during the wash, hot water fills the unit, increasing wash time and water usage. A dual-pump design in the dishwasher uses half of the water of a one-pump design. The primary pump circulates fresh incoming water, while the secondary pump eliminates any soil residue from previous wash cycles. Variable cycle selections or options for running smaller or less powerful loads will save water when the unit is not as full or not so dirty. The Energy Guide compares the initial cost and long term energy savings to other similar models with the same cycles, style, and capacity, and when energy-efficiency is a priority over all other considerations, the ENERGY STAR® rating should be used.

ADVANTAGES: Saves water and energy.

DISADVANTAGES: Not available from all manufacturers, higher initial cost.

3. CONSIDER REPLACING THE OVEN.

To improve overall efficiency, the best selection may be a self-cleaning oven. These have more insulation because of the extreme cleaning temperature, and this reduces energy loss during normal use. In addition, a convection oven uses a fan and the heating elements to cook more evenly and quickly, resulting in considerable energy savings over a conventional oven. Speed cooking is a new technology using a combination of heat from lightwave energy and microwaves to reduce the amount of cooking time without sacrificing taste. Similar to the traditional oven, food can be roasted, baked, or broiled. Speed cooking ovens are available from several manufacturers including Wolf and GE Appliances.

ADVANTAGES: Energy savings. Some over-the-range speed-cook ovens will retrofit in the hood location.

DISADVANTAGES: Higher initial cost; some require a 240V hookup.

4. CONSIDER REPLACING THE WASHER AND DRYER.

If the home being rehabed has a laundry room or area with equipment, these appliances may need replacement. Horizontal axis washing machines significantly reduce water consumption as a result of improved technology and the reduced water fill level. There is no agitator; rather, the clothes are forced by gravity into the water as the tub cycles. In combination with horizontal axis dryers, they can be stacked,



FIGURE 7

FRIGIDAIRE HORIZONTAL AXIS WASHER AND DRYER

installed below a countertop, or raised to a comfortable height. Frigidaire, GE, and Maytag are some of the manufacturers who offer horizontal axis washers and dryers. The Energy Guide compares the initial cost and long term energy savings to other similar models with the same cycles, style, and capacity, and when energy-efficiency is a priority over all other considerations, the Energy Star rating should be used.

ADVANTAGES: Energy savings; improved access.

DISADVANTAGES: Higher initial cost.

FURTHER READING

“Kitchens; A Smorgasbord of Energy Savings,” Bruce Sullivan, *Home Energy Magazine*, Reprint.

No Regrets Remodeling, Energy Auditor & Retrofitter, Inc., 1997.

PRODUCT INFORMATION

U.S. Environmental Protection Agency ENERGY STAR Program, 401 M. Street SW (6202J) Washington, D.C. 20460; 888-STAR-YES (782-7937); www.energystar.gov.

Frigidaire Home Products, 6000 Perimeter Dr., Dublin, OH 43017; 614-792-4100; 614 792-4073 (fax); www.Frigidaire.com.

GE Appliances, Appliance Park, Louisville, KY 40225; 800-626-2000; 502-452-7876; 502-452-0880 (fax); www.ge.com/appliances.

Jenn-Air Products, 403 West 4th St. North, Newton, IA 50208; 800- 536-2741; 317-545-2271 (fax); www.jennair.com.

Maytag Corp., 403 W. 4th St. Newtown, IA 50208; 888-462-9824; 515- 792-7000; 515-791-8395 (fax); www.maytag.com.

Northland Kitchen Appliances. PO Box 400, Greenville, MI 48838; 800-223-3900; 616-754-0970 (fax).

Wolf Range Co., 19600 S. Alameda St., Compton, CA 90221; 301-637-3737; 310-637-7931 (fax).

6

SINKS & LAVATORIES

6.1

SURFACE MAINTENANCE AND REPAIRS

ESSENTIAL KNOWLEDGE

Sink and lavatory surfaces can be damaged through years of use. The maintenance and repair of a sink or lavatory will depend on its materials and fabrication. If the fixture is otherwise functional, rehab work might focus on refinishing or rejuvenating the fixture surface. Dirt and bacteria are often found in seams between the countertop surface and the sink or lavatory; integral or undermount sinks can reduce or eliminate such seams.

TECHNIQUES, MATERIALS, TOOLS

1. REFINISH CULTURED STONE.

Also referred to as cast polymers, cultured stone is durable and easy to maintain. Cultured stone is made from chips of natural stone embedded in a polyester resin, which consists of polyester resin and alumina trihydrate combined to reproduce the veined appearance of natural onyx or alabaster. Tiny fractures in the gel topcoat are common problems in cast polymers. Fractures usually occur around the drain which is exposed to the thermal shock of alternate hot and cold water temperatures. Tightening the lock nut at the drain only slightly more than finger tight can help eliminate the cracking and crazing that occurs over time. Minor scratches in the gel top coat are buffed out using a polishing pad, and deep scratches or chips should be repaired by a porcelain repair company.

ADVANTAGES: Wide color and design options; integral sinks eliminate seam.

DISADVANTAGES: Care must be taken when installing the drain to prevent tiny fractures in the surface coat.

2. REPAIR VITREOUS CHINA.

Vitreous china is a common material for lavatories, and it is a form of ceramic and porcelain that is vitrified. Patterns on china may be applied at several stages of the firing process, some more durable than others. Vitreous china is naturally stain resistant and durable, although pitting can form from use of abrasive cleaners. A ceramic-like epoxy from Abatron can be used to fill any cracks or pits on the surface. The surface must first be cleaned and free of dust and debris, and after two or three recommended coats, curing continues for up to two weeks. The hardening and curing process can be accelerated with temperatures around 200°F.

ADVANTAGES: The glass-like appearance is favored for its sanitary characteristics. Epoxy is effective on moist or wet surfaces, and ideal for small areas.

DISADVANTAGES: Refinishing the entire fixture is labor intensive, and should be left to a professional for a uniform appearance. Decals applied to the glaze will not be as durable if the fixture was not fired at a high enough temperature.

3. REPAIR ENAMELED STEEL.

Although the surface has the same properties as enameled cast iron, the steel base is not as strong or durable. Because the steel is smooth, these sinks have a greater tendency to chip and wear. Rust stains that appear as a result of chipped or worn enamel can be removed with naval jelly, muriatic acid, or diluted phosphoric acid. Touch-up paints and epoxies that resist corrosion, such as Abatron, are available. The cost of refinishing enameled steel does not exceed the cost of a replacement sink. If the existing sink cannot be easily removed or replaced, refinishing usually will exceed the cost of a replacement sink.

ADVANTAGES: Less costly material and touch-ups.

DISADVANTAGES: Color matching can be difficult; patched areas do not wear as well as the original surface.

4. REPAIR OR REFINISH ENAMELED CAST IRON.

Finished with a smooth enamel top coat, cast iron sinks are durable and will last indefinitely. Non-abrasive cleaners remove surface dirt, but a mild abrasive should be used to remove ground-in dirt. Rust stains that appear as a result of worn enamel can be removed with naval jelly, muriatic acid, or diluted phosphoric acid. The enamel can be chipped if a hard blow bends the cast iron base. If the sink is irreplaceable or cannot be removed easily, the surface can be professionally refinished with a polyurethane-base coating. First, the surface is acid-etched, and scratches and dents are filled. The sink is then sanded and primed with a bonding coat, and glaze layers are applied. Any glaze applied to the surface without a chemical bond or acid-etching will likely peel.

ADVANTAGES: Enameled cast iron is durable and does not chip easily.

DISADVANTAGES: Often the cost of refinishing exceeds the cost of a replacement sink.

5. MAINTAIN STAINLESS STEEL.

Steel gauge, nickel content, and finishing technique determines the quality of the stainless steel. The most durable sink is 18 gauge; 20 gauge is acceptable, and 22 gauge should only be used in budget construction. Better sinks will be insulated on the underside to deaden sound. Stainless steel is stain resistant and hardwearing. The surface should be free of dirt, stains, and fingerprints to preserve corrosion resistance. Scratches in the surface cannot be repaired, but a brushed finish will conceal any fine scratches and watermarks on the surface.

ADVANTAGES: Large number of design and style options.

DISADVANTAGES: Middle- and low-range products usually do not have insulation to reduce sound. Surface should be cleaned whenever dirt or stains are visible.

6. REPAIR SOLID SURFACE.

All solid surface sinks and lavatories are homogeneous, made of polyester, acrylic, or a polyester and acrylic blend. Each manufacturer has developed a unique composition, some including mineral fillers to improve durability or fire-retardant properties. Sinks can be integral with a solid surface counter or undermount. Because of the homogeneous makeup, scratches or burns in the solid surface can be removed with a scouring pad, 320 to 400 grit sandpaper, or steel wool. More serious cuts or burns can be buffed out by a solid surface technician.

ADVANTAGES: Integral solid surface sinks create an invisible seam between the counter and the sink; many colors and styles.

DISADVANTAGES: Can be costly.

FURTHER READING

“1999 Buyer’s Guide,” *Kitchen and Bath Business*, Feb. 1999.

“Annual Directory and Buyer’s Guide.” *Kitchen and Bath Design News*, Feb. 1999.

Bathroom Industry Technical Manual; Volume #3, Bathroom Equipment and Materials, Ellen Cheever, CKD, CBD, ASID, National Kitchen and Bath Association, 1997.

The Healthy Household, Lynn Marie Bower, Healthy House Institute, 1995.

Kitchen Industry Technical Manual; Volume #3, Kitchen Equipment and Materials, Ellen Cheever, CKD, CBD, ASID, National Kitchen and Bath Association, 1996.

This Old House Journal Guide to Restoration, Penguin Books, 1992.

PRODUCT INFORMATION

Abatron, Inc., 5501 95th Ave., Kenosha, WI 53144; 414-653-2000; 414-653-2019 (fax); www.abatron.com.

Avonite, Inc., 1945 Hwy. 304 Belen, NM 87002; 800-428-6648; 505-864-7790 (fax); www.avonite.com.

Dupont Corian, Barley Mill Plaza, PO Box 80012, Building 12, Wilmington, DE 19880; 800-426-7426; 302-992-2855 (fax); www.corian.com.

Surell, Formica Corp., 10155 Reading Rd., Cincinnati, OH 45241; 513-786-3261; 513-786-3024 (fax); www.formica.com.

Gibraltar, WilsonArt, Int'l Inc., 2400 Wilson Pl. Temple, TX 76504; 800-433-3222; 254-207-7000; 254-207-2545 (fax); www.wilsonart.com.

6.2

WATER PURIFICATION

ESSENTIAL KNOWLEDGE

Lead pipes and solder used in residential and municipal water systems at the beginning of the 1900s contribute to water pollution. Older homes with vintage plumbing may benefit from a purification system to ensure water quality. No filtration system can remove all pollution from water, and the correct filtration system depends on the contaminants present in the water.

TECHNIQUES, MATERIALS, TOOLS

1. INSTALL A CARBON FILTER ADAPTER OR FAUCET.

Carbon removes many organic contaminants from the water that result in odor and bad taste, as well as dissolved gases (including chlorine), most pesticides, many chemicals, and radon gas. Although there are many varieties, block and granulated carbon are most commonly used in filters. Granulated carbon has a pitted surface to increase its area and absorption capacity, and carbon powder in a block forms a matrix structure to absorb contaminants. In addition, carbon block eliminates heavy metals and matter particles. Moen, Price Pfister, and Ultraflo all offer integrated filter faucets. A carbon filter attachment screws onto the existing faucet, and the filter is either granulated carbon or carbon block. A faucet with an integrated filter in the neck or base of faucet allows the user to select unfiltered cooking and cleaning water or filtered drinking water.

ADVANTAGES: No separate tap is needed; base cabinet storage space below is maintained. An adapter is inexpensive and easy to install.

DISADVANTAGES: Filters need to be replaced every three months; can become a source of pollution if not maintained. Other fixtures in the house are not filtered.

2. INSTALL AN UNDER-COUNTER CARBON FILTRATION SYSTEM.

Under-counter carbon filtration systems often use two separate carbon block filters to improve reduction of pollution. Filters should be replaced every six months. A combination of carbon filters is available and should be selected to filter anticipated pollution.

ADVANTAGES: Less expensive than a reverse osmosis system; system can be installed in the basement or elsewhere in a remote but close location to the sink.

DISADVANTAGES: Eliminates some storage space under the sink; some farmhouse style sinks with integral front apron may not accommodate system. Separate filtered water faucet is needed in addition to primary faucet.

4. INSTALL AN UNDER-COUNTER REVERSE OSMOSIS AND CARBON COMBINATION FILTRATION SYSTEM.

Reverse osmosis is the process by which water is forced under pressure through a semipermeable membrane that separates water from dissolved solids, heavy metals, asbestos, radioactive particles, and some bacteria. When lead and nitrates are present in the drinking water, a reverse osmosis system is a better solution. A combination of reverse osmosis and carbon is needed because reverse osmosis systems cannot be used independently with chlorinated supply water. Chlorinated water first needs to be filtered through the carbon.

ADVANTAGES: The combination of carbon and reverse osmosis will block almost all contaminants. System can be installed in the basement within close proximity to preserve base cabinet storage.

DISADVANTAGES: Reverse osmosis systems sometimes process slowly and can eject three or four gallons of water for every gallon filtered. Membranes will need to be replaced every one to three years. Eliminates some storage space under the sink; some farmhouse style sinks with integral front apron may not accommodate system. Separate filtered water faucet is needed in addition to primary faucet. Can be expensive compared to other filtration systems.



FIGURE 1

GE SMARTWATER REVERSE OSMOSIS FILTRATION SYSTEM

FURTHER READING

The Healthy Household, Lynn Marie Bower, Healthy House Institute, 1995.

Kitchen Industry Technical Manual; Volume #2, Kitchen Mechanical Systems, Marylee McDonald; Nicholas Geragi, CKD, CBD, NCIDQ; Ellen Cheever, CKD, CBD, ASID, National Kitchen and Bath Association, 1996.

Prescriptions for a Healthy House, Paula Baker, AIA; Erica Elliot, MD; John Banta, InWord Press, 1998.

“Shopping Smart; On the Waterfront,” *American Homestyle and Gardening*, Alexandra Bandon, March 1999, p. 40.

PRODUCT INFORMATION

Everpure, Inc., 660 Blackhawk Dr., Westmont, IL 60559; 800-323-7873; 630-654-1115 (fax); www.everpure.com.

Franke Triflow, Franke Kitchen Systems Division, 3050 Campus Dr., Hatfield, PA 19440; 800-626-5771, 215-822-5873 (fax); www.franke.com.

GE SmartWater, GE Appliances, Appliance Park, Louisville KY 40225; 800-626-2000; 502-452-0880 (fax); www.ge.com/appliance.

Moen Puretouch, Moen, Inc., 25300 Al Moen Dr., N. Olmstead, OH 44070; 800-289-6636; 440-962-2000; 440-962-2770 (fax); www.moen.com.

Price Pfister Teledyne Water Pik, Price Pfister, Inc., 13500 Paxton St., Pacoima, CA 91333-4518; 818-896-1141; 818-897-4047 (fax); www.PricePfister.com.

Ultraflo Corp., PO Box 2294, 310 Industrial Ln., Sandusky, OH 44870; 800-760-5629; 419-626-8182; 419-626-8183 (fax); www.ultraflo.com.

6.3

WATER CONSERVATION

ESSENTIAL KNOWLEDGE

Water conservation is a critical aspect of energy and resource management, and it should be considered in any kitchen rehab project. Many of the devices discussed are available at little or no cost from utility companies.

TECHNIQUES, MATERIALS, TOOLS

1. INSTALL LOW-FLOW FAUCET.

Although there are no code requirements for rehab construction, a flow rate of 2.0 gallons per minute (gpm) in lavatory faucets and 2.5 gpm in kitchen faucets is recommended.

ADVANTAGES: Reduces water consumption.

DISADVANTAGES: Reduces pressure of water flow, but an aerator can increase pressure of the available water as it leaves the faucet.

2. RETROFIT A FAUCET AERATOR.

Replace the faucet head screen with a faucet aerator. Air is added to water to provide good pressure and a steady stream of water, and the flow seems greater than it actually is. Neoperl and Resource Conservation offer aerator attachments. Again, a flow rate of 2.0 gpm in lavatory and 2.5 gpm in kitchen faucet aerators is recommended. Periodically, the aerator should be unscrewed from the spout and cleaned.

ADVANTAGES: Highly efficient, inexpensive, and easy to install.

DISADVANTAGES: Type of spray or flow may not be desirable.

3. REPLACE FITTINGS.

Fittings for the sink can be repaired by removing the faucet and flushing out any debris. Leaking fixtures that are older may be repaired by replacing washers, but most newer fittings are washer-less and eliminate

future leaks from worn washers. If this does not improve the flow and the fitting is not repairable, replacement provides the opportunity for improved access and function (refer to 4.4 Maximize Access and Function).

ADVANTAGES: Inexpensive.

DISADVANTAGES: Conditions that are not obvious may exist and may need professional attention.

FURTHER READING

Bathroom Industry Technical Manual; Volume #3, Bathroom Equipment and Materials, Ellen M. Cheever, CKD, CBD, ASID, National Kitchen and Bath Association, 1997.

Designing and Remodeling Bathrooms, Ortho Books, 1990.

No Regrets Remodeling. Energy Auditor & Retrofitter, Inc., 1997.

“Remodeling Bathrooms; Let the Energy Savings Flow,” David Johnson, *Home Energy Magazine*, Reprint.

The Smart Kitchen, David Goldbeck, Ceres Press, 1994.

PRODUCT INFORMATION

Neoperl, Inc., 171 Mattatuck Heights, Waterbury, CT 06705; 203-756-8891; 203-754-5868; www.neoperl.com.

Resource Conservation, Inc., 39 Mapletree Ave., Stamford, CT 06906; 800-243-2862; 203-964-0600; 203-324-9352 (fax); www.resourcesconserv.com.

6.4

MAXIMIZE ACCESS AND FUNCTION

ESSENTIAL KNOWLEDGE

Kitchen access is important and bathroom access is critical to all household members. Rehabbing presents an opportunity to create flexibility at the sink so that different tasks can be performed safely and comfortably by users of differing age, stature, and ability.

TECHNIQUES, MATERIALS, TOOLS

Products to improve access at the kitchen or bathroom sink include:

1. INSTALL DIVERTER FOR SPRAY.

On a kitchen or bath faucet, a diverter permits the user to easily switch from an aerator spray to a needle spray. The diverter system is designed into a plastic integrated pull-out faucet or the traditional faucet with separate spray. Since 1994, manufacturers have fused the rubber diverter to the plastic handle. In some cases, a pull-out spray in the bath will make it easier to wash hair in the sink or to give sponge baths; in the kitchen it eases rinsing food and dishes.

ADVANTAGES: Improves flexibility.

DISADVANTAGES: Additional drilled hole in the sink is needed for a separate diverter spray.

2. INSTALL SCALD PROTECTION DEVICE AT FAUCET.

Changes in water pressure in the house can cause sudden changes in water temperature at a kitchen or

bathroom sink. Water temperature can be controlled by balancing the hot and cold water inlets with either temperature or pressure mixing. While presetting the water temperature can be considered a luxury, temperature control is also a safety feature. For scald protection, the water flow is controlled by a thermostat. When the temperature reaches the 120°F range, the faucet will automatically shut off. Some faucets have a restart button that purges the hot water and restarts the supply. In a retrofit, a temperature-limiting valve can be installed under the lever and escutcheon, allowing the temperature to be adjusted. Many manufacturers, including Grohe and Resource Conservation, manufacture faucets with temperature and pressure balancing protection.

ADVANTAGES: Some scald-protection devices can be retrofitted into an existing faucet. Temperature control is safe and convenient.

DISADVANTAGES: Liquid elements and metal may not respond well over time due to damaging water conditions.

3. INSTALL GOOSENECK OR HIGH ARC SPOUT.

When kitchen sink depth is limited, a tall gooseneck spout, often used in laboratories, facilitates filling tall pots.

ADVANTAGES: Increases clearance for tall pots.

DISADVANTAGES: Increased height can result in splashing in shallow bowls.

4. INSTALL INSTANT HOT AND INSTANT COLD.

Hot water dispensers at the sink improve function in the kitchen by providing instant hot water at about 190°F for tea, soup, or coffee. Cold water dispensers provide instant cold water available for drinking or cooking. Franke offers either hot water or cold water dispensers, while Steamin' Hot from In-Sink Erator provides hot water only.

ADVANTAGES: Eliminates need to heat water. Cold water dispenser eliminates need for water dispenser at the refrigerator.

DISADVANTAGES: Cold water dispenser is more costly because the dispenser and chiller are usually sold separately.

5. INSTALL POT-FILLER FAUCET.

Mounted to the wall over the stove, the pot-filler faucet fills large pots on the front and back burners. The jointed arm can be folded out of the way when cooking. Chicago Faucets and Franke are two manufacturers that offer different variations of pot-filler faucets.

ADVANTAGES: Eliminates carrying a heavy pot full of water from the sink to the stove.

DISADVANTAGES: Requires water lines, and may not be cost effective if pipes have to be installed.

6. INSTALL PEDAL VALVE CONTROLS.

Pedal Valve's Pedalwork foot controls can be easily installed to allow the user to operate the faucet by pressing foot pedals, in addition to traditional hand operation. The pedals are located in the toe-kick space under the base cabinet.

ADVANTAGES: Easy to install, inexpensive, color coordinated.

DISADVANTAGES: Minor adjustments to the sink cabinet.

7. CONSIDER SHAPE, SIZE, AND NUMBER OF SINKS.

In both the kitchen and the bath, adding a sink increases the available work space for multiple users. A variety of sizes and shapes is available to fit many spaces and allow for a second sink at a different height than the original to accommodate people of varying stature.

ADVANTAGES: Improves access and increases function.

DISADVANTAGES: Expense can be considerable; space may not be available.

8. INSTALL TOUCHLESS FAUCET CONTROL.

Touchless faucet controls turn on when they sense motion. Because water cannot be left on, touchless

controls improve water conservation. Although electronic operated models are available, a battery operated model may work better for a rehab project. Temperature and flow rate are preset, but some models include handles for manual override. Residential bathroom and kitchen faucets are available from Aqua Touch, KWC, and Geberit.

ADVANTAGES: Eliminates turning handles off and on when strength is minimal. Decreases unnecessary water consumption.

DISADVANTAGES: Battery operated faucet needs battery replacement about once a year. Occasionally responds to unintended motion.

FURTHER READING

“1999 Buyer’s Guide.” *Kitchen and Bath Business*, Feb. 1999.

“Annual Directory and Buyer’s Guide.” *Kitchen and Bath Design News*, Feb. 1999.

Bathroom Industry Technical Manual; Volume #3, Bathroom Equipment and Materials, Ellen Cheever, CKD, CBD, ASID, National Kitchen and Bath Association, 1997.

ProMatura Enabling Products Sourcebook 2, Margaret A. Wylde, Ph.D.; Deany Hillhouse; Joe Austin; Kristen Suslar Guinn, National Kitchen and Bath Association, 1995.

Universal Kitchen and Bath Planning, Mary Jo Peterson, CKD, CBD, CHE, McGraw-Hill, 1998.

PRODUCT INFORMATION

Aqua Touch, 800 Ellis St., Glassboro, NJ 08028; 800-220-3036; 609-881-7890; 609-881-7938.

Chicago Faucets; 847-803-5000; 847-298-3101 (fax); www.chicagofaucet.com.

Franke, Instant Hot/Instant Cold, Franke Kitchen Systems Division, 3050 Campus Dr., Hatfield, PA 19440; 800-626-5771, 215-822-5873 (fax); www.franke.com.

Geberit Mfg., Inc., PO Box 2008, 1100 Boone Dr., Michigan City, IN 46360; 800-225-7217; 219-879-4466; 219-872-8003 (fax); www.geberit.com.

Grohe, 241 Covington Dr., Bloomingdale, IL 60108; 630-582-7711; 630-582-7722 (fax); www.groheamerica.com.

In-Sink-Erator; 4700 21st St. Racine, WI 53406; 800-558-5712; 414-554-3534; 414-554-3639 (fax); www.insinkerator.com.

KWC Faucets, Inc., 1555 Oakbrook Dr., St 110, Norcross, GA 30093; 877-592-3287; 770-248-1600; 770-248-1608 (fax); www.kwcfaucets.com.

Pedal Valves, Inc., 13625 River Rd., Luling, LA 70070; 800-431-3668; 504-785-9997; 504-785-0082 (fax); www.pedalvalve.com.

ScaldSafe, Resource Conservation, Inc., 39 Mapletree Ave., Stamford, CT 06906; 800-243-2862; 203-964-0600; 203-324-9352 (fax); www.resourcesconserv.com.

Speakman Sensor Flo, PO Box 191 Wilmington, DE 19899; 800-537-2107; 800-977-2747 (fax).

7

TUBS & SHOWERS

7.1

SURFACE MAINTENANCE AND REPAIRS

ESSENTIAL KNOWLEDGE

Tub and shower surfaces can become damaged through years of use. The tub and shower are often the areas in the bathroom that show the most wear. The maintenance and repair of a tub or shower will depend on its materials and fabrication. If the fixture is otherwise functional, rehab work might focus on refinishing or rejuvenating the surface.

TECHNIQUES, MATERIALS, TOOLS

1. REPAIR FIBERGLASS TUB AND SURROUND.

Fiberglass is the backing material used to reinforce the polyester gel-coat finish surface. If the gel coat becomes damaged, a fiberglass repair expert should be contacted to repair the surface.

ADVANTAGES: Least expensive finish and easy to repair.

DISADVANTAGES: Polyester gel coat is not as durable as other finish materials.

2. REPAIR ACRYLIC TUB, BASE, AND SURROUND.

Acrylic and acrylonitrile butadiene styrene (ABS) sheets are thermoformed to fabricate the unit, and are harder finishes than polyester gel coats. The color is continuous throughout, and the material can usually be sanded out and then buffed if the surface is scratched. An automotive-type rubbing compound and a non-grain paste wax will help polish a dulled surface.

ADVANTAGES: Formed tub and surround, shower base, or separate surrounds are available.

DISADVANTAGES: Limited styles and shape.

3. REPAIR CULTURED STONE BASE AND SURROUND.

Also referred to as cast polymer, cultured stone is durable and easy to maintain. It is made from chips of natural stone embedded in a polyester resin; cultured onyx consists of polyester resin and alumina trihydrate, which are combined to reproduce the veined appearance of natural onyx or alabaster. Minor scratches in the gel coat can be buffed out using a polishing pad. Tiny fractures in the gel coat are common problems in cast polymers. Damage usually occurs around the drain, which is exposed to the thermal shock of alternate hot and cold water temperatures. Deep scratches or chips should be repaired by a porcelain repair company.

ADVANTAGES: Wide color and design options.

DISADVANTAGES: Repairs do not always match the original surface.

4. INSTALL A LINER OVER EXISTING TUB OR SHOWER BASE.

Rusted, chipped, and worn bathtubs and shower bases often cannot be rejuvenated. A liner is formed as an exact fit over the existing fixture. Manufactured from co-extruded acrylonitrile butadiene styrene (ABS) and acrylic, ReBath Bathtub Liners, Shower Base Liners, and Wall Surrounds are nonporous.

ADVANTAGES: More affordable than replacement, and minimal installation time.

DISADVANTAGES: Installer must be authorized by manufacturer to install; limited color choice.



FIGURE 1

INSTALLATION OF REBATH BATHTUB LINER

5. REPAIR ENAMELED STEEL TUB.

Enameled steel surfaces have the same properties as enameled cast iron, although the steel tub base is not as strong or durable. Because the steel is smooth, the fixtures have a greater tendency to chip and wear. Rust stains may appear as a result of worn enamel, and can be removed with naval jelly, muriatic acid, or diluted phosphoric acid. Touch-up paints and epoxies that resist corrosion, such as Abatron, are also available. Enameled steel can be refinished using a similar process to enameled cast iron, but often the cost of repair exceeds the cost of a replacement tub.

ADVANTAGES: Less costly material.

DISADVANTAGES: Tends to chip more easily than enameled cast iron. Color matching can be difficult and patched areas do not wear as well as the original.

6. REPAIR OR REFINISH ENAMELED CAST IRON TUB.

Finished with a smooth enamel top coat, cast iron tubs are heavy, durable, and quiet. They will last indefinitely, although the enamel can be chipped if a hard blow bends the cast iron base. Non-abrasive cleaners should be used to remove surface dirt, but a mild abrasive is the best choice to remove ground-in dirt. If damage to the enamel is significant, or the tub cannot be replaced, the surface can be professionally refinished with a polyurethane-base coating. The surface is first acid-etched, and scratches and dents are filled. The entire tub is then sanded and primed with a bonding coat, and glaze layers are applied. Any refinishing product applied to the surface without a chemical bond or acid-etching will likely peel. If an existing cast iron tub is beyond repair, it can be demolished with a sledge hammer and removed.

ADVANTAGES: Enameled cast iron does not chip easily.

DISADVANTAGES: Cast iron is a good conductor of heat, and will cool bath water more quickly than a plastic-based material. Costly to refinish.

7. REPAIR SOLID SURFACE BASE AND SURROUND.

All solid surface shower bases and surrounds are homogeneous polyester, acrylic, or a polyester and acrylic blend. But each manufacturer has developed a unique composition, some including mineral fillers to improve durability properties. Because of the homogeneous makeup, scratches or burns in the solid surface can be removed with a scouring pad, 320 to 400 grit sandpaper, or steel wool. More serious cuts or burns can be buffed out by a solid surface technician. The invisible seam between the base and the surround eliminates water seepage through the seam into the floor and wall. Installation and major repairs should be by a technician authorized by the manufacturer.

ADVANTAGES: Invisible seams between the base and surround; many colors, sizes, custom shapes available.

DISADVANTAGES: More costly than other plastic bases and surrounds.

8. REPAIR OR REPLACE CERAMIC TILE AND GROUT.

Though ceramic tile rarely chips, bacteria can collect in the damaged area. Household cleaners containing acid, bleach, or vinegar should be avoided for daily cleaning because they will etch the tile and grout in time. Mold in the grout lines can be killed with a 1-to-3 ratio of bleach to hot water. Tile is susceptible to water penetration at the joints; if the grout becomes wet water can seep behind the wall tile and damage the substrate. (Refer to section 7.2 MOISTURE CONTROL for installation techniques). If the tile is broken, chipped, cracked, or loses adhesiveness, an individual tile or a section of tile can be removed and replaced. Care must be taken to remove tile without damaging surrounding tiles. Remove the surrounding grout with a hand-held grout saw or diamond blade grinder. Then break the damaged tile into several pieces, and pry the small sections of tile from the substrate. A chisel should be used to remove the tile from the backer board without damaging the substrate. Insert new tile with adhesive and level to adjacent existing tiles. On walls, tape the tile into place until dry. Any loose grout should be picked off. Grout is available as cement, vinyl, or epoxy-based. Epoxy-based grout is stronger and more impervious to water, mildew, and stains, but more care is required during installation. Penetrating or surface silicone cleaner applied to grout increases its stain resistance.

ADVANTAGES: If extra tiles are available, this repair is relatively easy.

DISADVANTAGES: Sometimes difficult to match grout colors. Epoxy-based grouts tend to be more costly than others.

9. REPAIR STONE BASE AND SURROUND.

If there are minor cracks, stone can be repaired using an overfill and grind technique. The damaged area is cleaned and dried before it is filled with an epoxy or polyester matrix combined with a ground stone or sand aggregate to produce a mortar-like mixture. To eliminate an obvious straight-line man-made repair, the edges of crack can be chipped and widened, replicating the existing veins. After the mixture cures, the fill is ground and polished. A professional stone fabricator for the repairs can ensure a good bond and lasting results. Marble should not be used in steam showers because the marble can pit, delaminate from the substrate, or deteriorate around steam vents. Some types of marble will develop rust spots or discolor. Sealers applied to the stone surface will not prevent such problems.

ADVANTAGES: Aggregate will improve similarity between stone and fill; epoxy is effective on wet surfaces.

DISADVANTAGES: Epoxies may yellow.

FURTHER READING

“1999 Buyer’s Guide.” *Kitchen and Bath Business*, Feb. 1999.

“Annual Directory and Buyer’s Guide.” *Kitchen and Bath Design News*, Feb. 1999.

Bathrooms: How To, James A. Hufnagel, Hometime Video Publishing, Inc., 1998.

Bathroom Industry Technical Manual; Volume #3, Bathroom Equipment and Materials, Ellen Cheever, CKD, CBD, ASID, National Kitchen and Bath Association, 1997.

Home Improvement for Dummies, Gene and Katie Hamilton, IDG Books Worldwide, 1998.

“Repairing Stone Utilizing the Overfill Grind Technique,” James Alseth, *Dimensional Stone*, August 18, 1998, p. 29.

PRODUCT INFORMATION

Flitz International Ltd., 821 Mohr Ave., Waterford, WI 53185; 800- 558-8611; 414-534-5898; 414-534-2991 (fax).

Marble Renewal, PO Box 56349, Little Rock, AR 72215; 501-663-2080; 501-663-2401 (fax); www.marblerenewal.com.

Re-Bath Corp. Mesa, AZ 85210-4613; 800-426-4573; 602-844-1575; 602-833-7199 (fax).

Stone Industry.Com, 1014 Makani Rd., Pukalani, HI 96768; 808-572-1222; 808-572-6884 (fax); www.stoneindustry.com.

Worldwide Refinishing Systems, 1020 N. University Parks Dr., Waco, TX 76707; 254-745-2432; 254-745-2588; www.wrefinishing.com.

7.2

MOISTURE CONTROL

ESSENTIAL KNOWLEDGE

Moisture control can be an issue in the kitchen and is a major concern in the bathroom. Lack of proper ventilation and improper installation and sealing of fixtures at walls can lead to excessive moisture, which can result in damage if not quickly removed. Indicators of moisture build-up in the bath include mold, mildew, failing grout, dislodged tiles, water stains, or rotted walls. Moisture can permeate wallboard, moving from the warm side of the wall to the cool side, which varies according to climate. Steam can condense as it hits a cool surface and pool at the base of that surface. Any damp area must completely dry out. Moisture damage will occur if there is not proper sealing or ventilation. In a rehab project, both the visible problem and its source must be repaired and corrected.

TECHNIQUES, MATERIALS, TOOLS

A number of approaches to reducing the effect of moisture problems in a rehab bathroom should be considered:

1. IMPROVE VENTILATION.

A good exhaust system is critical to moisture control in bathrooms because it will help prevent water from condensing and building up in the walls. Determine the proper cubic feet per minute (cfm) rating for the bathroom with the following formula:

cubic feet of room (L x W x H) x 8 air changes per hour x 60 minutes = required fan cfm rating

Controls should be placed on a timer so that the fan is on for 15 to 20 minutes after showering. A combination low-voltage fan and light, the Vent-Axia Fan n' Light from Coast Products, is a ceiling mount fixture that can be used in a tub or shower to help reduce moisture in the rest of the bathroom. The duct system should take the shortest and most direct route to the outside. It is important to plan for return or make-up air. In hot and humid climates, a powered system that cools and dehumidifies the fresh air is recommended. For more detail on exhaust systems, see *Volume 8: HVAC/Plumbing*.

ADVANTAGES: Removes some moisture and odors.

DISADVANTAGES: Make-up air must be considered; long lengths and bends in the duct work reduce efficiency.

2. REDUCE MOISTURE AT RECESSED LIGHTS.

Moisture can get into attic or other overhead spaces through recessed lighting (Fig. 2). Even when an "air-tight" recessed light is used in the bathroom, some moisture will penetrate into the structure above. The warm, moist air will condense or freeze on contact with a cold surface. Either an airtight box built around the fixture with insulation or a dropped soffit with an air barrier at the ceiling plane will reduce or eliminate moisture penetration through a recessed light.

ADVANTAGES: Reduces amount of moisture trapped in attic or proximate walls.

DISADVANTAGES: Thorough sealing and double sealing at and above recessed lighting adds labor and costs.

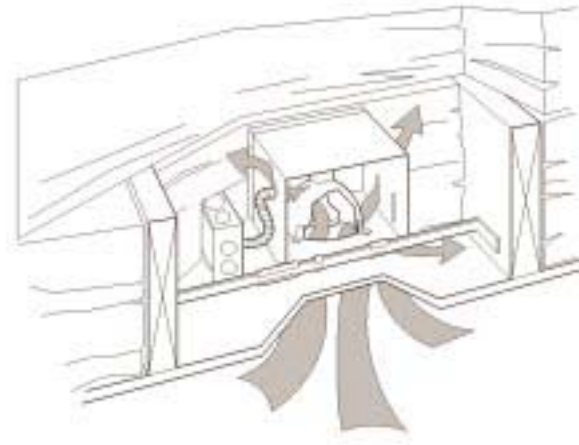

FIGURE 2

MOISTURE PENETRATING THROUGH RECESSED LIGHT FIXTURE INTO OVERHEAD SPACE

3. MANAGE WATER PENETRATION AT TILE

Small amounts of water penetrating the tile in showers or tub surrounds will be absorbed by cement backer board, and by the framing if the water passes beyond the backer board. To avoid the formation of rot and mildew, these materials must have a chance to dry out before they become saturated. Interior walls and exterior walls or roofs that receive direct sunlight will usually dry satisfactorily, but shaded exterior walls or roofs require special attention. Insulate the exterior wall or roof and apply a good, tight air barrier to the inside (4- or 6-mil poly, Tyvek, gypsum board, or paper-based wall sheathing; asphalt-impregnated felt should not be used inside the home). Then furr the wall or roof with flat 2x's running horizontally, and apply the backer board and tile. Gypsum board used behind tile (even water-resistant "green board") will not dry out as quickly as cement-based backer board. Behind leaking tile grout and cracks, the accumulated water will soon re-emulsify the adhesive and the tile will fall off. Also, mildew will form, fed by the cellulose in the paper face on the gypsum board. For rehab work, use cement-based backer board.

ADVANTAGES: Recognizes that tile work cannot be made permanently waterproof; prevents mold growth in wall and possible structural failure of tile.

DISADVANTAGES: Cement backer board is more difficult to cut and attach than gypsum board.

4. CHANGE INSTALLATION OF TILE SUBSTRATE AT TUB/SHOWER SEAM.

When tile overlaps the seam created by the green board and the shower base, the tile acts like a dam and a water reservoir is created. Problems often occur when the cut, unprotected end of the green board is installed at the seam of the shower base, exposing the capillary tubes that run from the reservoir up into the green board. Once the capillary tubes fill, the saturated substrate will eventually deteriorate. One way to solve this problem is to seal the cut edge of the green board with tile mastic in the field. The substrate and the tile should both be held off the shower pan or tub, by at least 1/4". The caulk will fill this gap between the tile and the surround, and a 1" weep hole in the caulk will allow water in the reservoir behind the tile to freely exit (Fig. 3).

ADVANTAGES: Structure of substrate is preserved.

DISADVANTAGES: Installation is not widely practiced; consult Further Reading sources for detail and clarification.

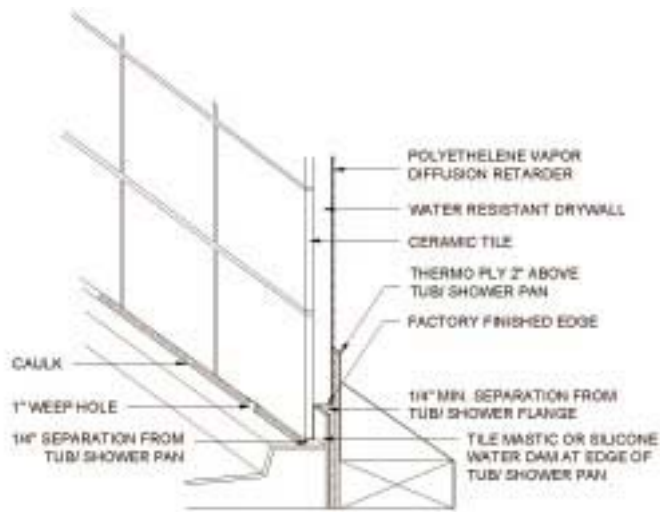

FIGURE 3

ONE-INCH WEEP HOLE IN CAULK WITH SUBSTRATE HELD OFF TUB/SHOWER FLANGE

FURTHER READING

ANSI Specification for the Installation of Ceramic Tile, Tile Council of America.

Bathroom Industry Technical Manual; Volume #2, Bathroom Mechanical Systems, MaryLee McDonald; Nick Geragi, CKD, CBD; and Ellen Cheever, CKD, CBD, ASID, National Kitchen and Bath Association, 1997.

“Build it Right the First Time,” E. David Pennebaker, *EEBA Excellence*, Winter 1998, p. 10-12.

“Durable Substrates for Thinsset Tile,” Michael Byrne, *Journal of Light Construction*, August 1996, p.40.

Handbook for Ceramic Tile Installation. Tile Council of America.

“Moisture Control in Bathrooms,” Marilou Cheple and Pat Huelman, *Home Energy Magazine*, March/April 1998.

No Regrets Remodeling. Energy Auditor & Retrofitter, Inc., 1997.

“Tile Wall Failures,” *EEBA Excellence*, E. David Pennebaker, Winter 1998, pp. 13, 17.

PRODUCT INFORMATION

Dens-Shield, Georgia-Pacific, 133 Peachtree St. NE, Atlanta, GA 30303; 800-255-6119; 913-236-7291 (fax).

Durock, U.S. Gypsum Industries, 125 S. Franklin St., Chicago, IL 60606; 800-621-9622; 312-606-4093 (fax).

Hardibacker, James Hardie Building Products, 10901 Elm Ave., Fontana, CA 92337; 800-942-7343.

Mapei Corp., 1350 Lively Blvd., Elk Grove Village, IL 60007; 800-922-6273.

Wonderboard, Custom Building Products, 13001 Seal Beach Blvd., Seal Beach, CA 90740; 800-282-8786.

Waterproof membranes, The Noble Co., 614 Monroe St. Grande Haven, MI 49417; 616-842-7844; 616-842-1547 (fax); www.noblecompany.com.

7.3

MAXIMIZE ACCESS AND FUNCTION

ESSENTIAL KNOWLEDGE

A rehab project that includes the tub, shower base or surround is an opportunity to incorporate universal design principles to safely and comfortably accommodate users of differing age, stature, and ability.

TECHNIQUES, MATERIALS, TOOLS

Suggestions to improve safety and access can be applied to faucet fittings and fixtures.

1. INSTALL SCALD PROTECTION DEVICES.

Although many devices regulate water temperature, devices that stop the flow of water, such as ScaldSafe from Resource Conservation, are recommended to provide scald protection. A temperature limiting valve is easily installed under the lever and escutcheon, and the limit can be set and later adjusted. Liquid and metal thermostatic systems expand and contract with temperature. When the temperature reaches the set limit, the faucet will shut off. Some faucets have a restart button that will purge out the hot water and restart the actuator. Pressure mixing and balancing systems adjust the flow of hot and cold water to protect against dramatic temperature changes due to sudden changes in water pressure.

ADVANTAGES: Can be retrofitted into an existing faucet.

DISADVANTAGES: Fluid elements and metal may not respond well over time due to damaging water conditions.

2. RELOCATE CONTROLS.

If the tub or shower surround is to be replaced, the existing control and diverter can be offset 6" towards the outside of the tub. The offset will allow one to turn on and test the water temperature and flow before entering the tub or shower. In the bathtub, the controls should be placed 17" to 30" above the floor; up to 48" in the shower. In a custom walk-in shower the controls should be placed at the point of entry.

ADVANTAGES: Improves access.

DISADVANTAGES: Requires replacement or repair of tub or shower wall.

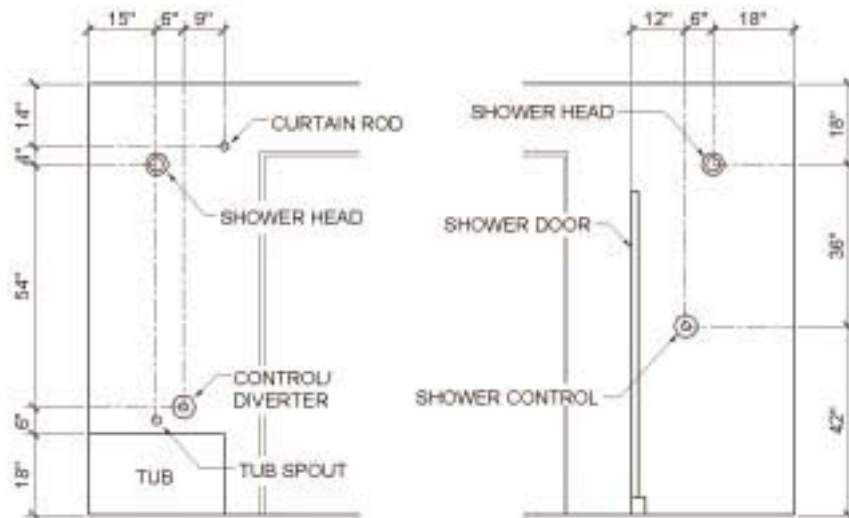

FIGURE 4

RELOCATE CONTROLS TO ENTRY SIDE OF TUBS AND SHOWERS

3. INSTALL BUILT-IN SEAT TO IMPROVE TRANSFER.

A built-in seat framed at the head of the tub or in a custom shower will provide a surface for transfer into the tub or shower. A depth of 15" is recommended with a preferred height of 18", and it should gently slope towards the tub or shower base at 1/4" per 12" to avoid standing water (Fig. 5). The transfer surface needs to withstand a minimum load of 300 pounds. The ceramic tile deck overlaps the tub flange to eliminate a permeable seam, and the tile should continue down the front of the seat. If glass doors are used, they must open up to the seat and a custom size may be needed. A shower curtain rod must extend over the seat, and an extra wide curtain or two curtains must be used.

ADVANTAGES: Improves access.

DISADVANTAGES: A built-in seat remains at a fixed height and can not be adjusted for changes in need. The recommended height of 18" is often higher than the top of the tub.

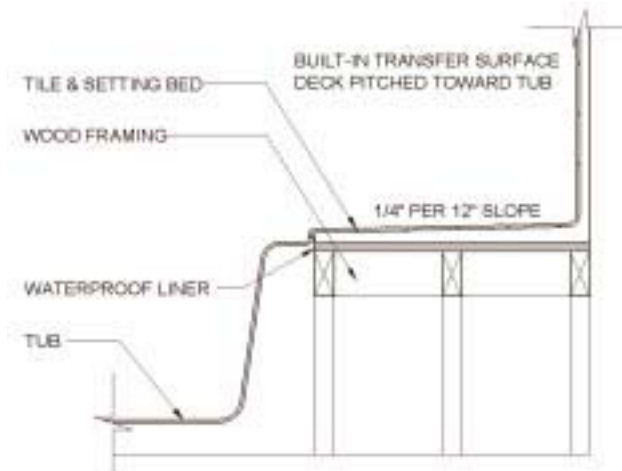

FIGURE 5

BUILT-IN TRANSFER SEAT DETAIL

4. INSTALL BLOCKING FOR GRAB BARS.

Grab bars improve safety and stability, and blocking should be installed throughout the bathtub area so that grab bars can be installed when and where they will be most effective. Grab bars should be placed at the point of entry and where a person shifts positions. Horizontal grab bars should be placed on all three walls at a height 33" to 36" above the floor. Vertical grab bars may be placed on the side walls for additional safety. In a rehab situation, with finished walls in place, grab bars can be added only where there are studs or if there is known blocking. When these options are not clear or not in the right location, a solid piece of wood (2x4 or 2x6) can be attached to the studs, and the grab bars attach to the solid wood.

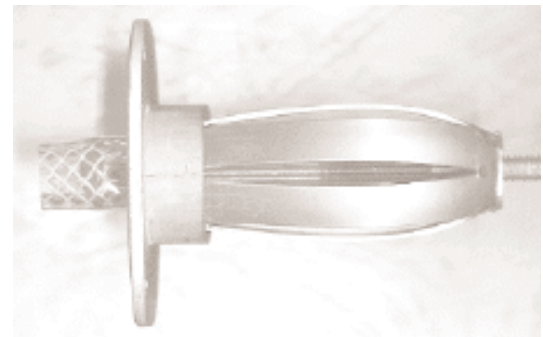
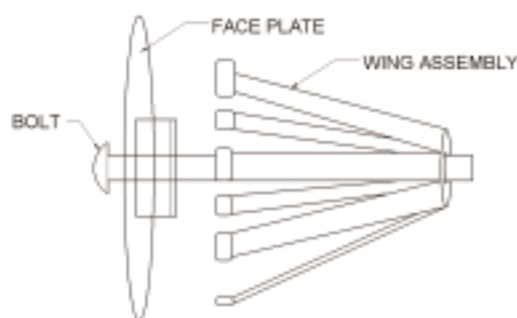

FIGURE 6

WINGIT FASTENER IN OPEN AND CLOSED POSITIONS

The top edge should be beveled so that it slopes slightly, and the entire surface should be covered with a waterproof material. Another solution, relatively new to the market, is the WingIt Grab Bar Fastening System from Pinnacle (Fig. 6), which can be installed into substrates such as drywall to fasten grab bars to the wall. Grab bars are available from many manufacturers including Hewi and Otto Bock.

ADVANTAGES: Improves access when needed. Reduces risk of slips and falling.

DISADVANTAGES: Future needs may change.

5. USE A "NO THRESHOLD" SHOWER BASE.

When possible, the curb entering the shower should be eliminated for safety and access. This works best in an oversized shower with the flow of water from the showerhead directed away from the entrance. When this is done, the floors should be set in mud rather than thinset and grout, and sloped gently (1/4" per foot maximum) toward the drain. A waterproof membrane below the shower area should be extended into the room to reduce the possibility of leaks from standing water. During framing, the floor should be planned to accommodate the thickness of the mud underlayment required to create the slope in the tile. This can also be done using a solid surface custom shaped base or manufactured curbless shower base.

ADVANTAGES: Improves safety and access; easier to maintain.

DISADVANTAGES: Requires attention to water flow and standing water to reduce risk of leaking.

FURTHER READING

Bathroom Industry Technical Manual; Volume #3, Bathroom Equipment and Materials, Ellen M. Cheever, CKD, CBD, ASID, National Kitchen and Bath Association, 1997.

ProMatura Enabling Products Sourcebook 2, Margaret A. Wylde, Ph.D.; Deany Hillhouse; Joe Austin; Kristen Suslar Guinn, National Kitchen and Bath Association, 1995.

Universal Kitchen and Bath Planning, Mary Jo Peterson, CKD, CBD, CHE, McGraw-Hill, 1998.

PRODUCT INFORMATION

Hewi Inc., 2851 Old Tree Drive, Lancaster, PA 17603; 717-293-1313; 877-439-4462; 717-293-3270 (fax).

Pinnacle Innovations Inc., 8 Martin Ave., South River, NJ 08882; 732-257-6900; 732-257-6926 (fax); www.wingits.com.

PlumbingProducts; www.plumbingproducts.com

Otto Bock Rehabilitation, 3000 Xenium Lane Minneapolis, MN 55441; 800-328-4088; 612-553-9464; 612-519-6150; www.ottobock.com.

Resource Conservation, Inc., 39 Mapletree Ave., Stamford, CT 06906; 800-243-2862; 203-964-0600; 203-324-9352 (fax); www.resourcesconserv.com.

7.4

WATER CONSERVATION

ESSENTIAL KNOWLEDGE

A bath rehab is an opportune time to consider strategies for water conservation. Standard showerheads typically provide 2.5 to 3 gallons per minute (gpm). Showerheads are available with a flow restriction of 1.7 gpm, which reduces water use. Products that are a substantial upgrade over the existing fixture should be selected to achieve maximum long-term water conservation.

TECHNIQUES, MATERIALS, TOOLS

Suggestions to limit the flow of water without reducing function:

1. REPLACE FITTINGS.

Tub and shower controls may be difficult to operate due to years of use. Controls can be repaired by removing the nozzle or spray head and flushing out debris. Leaking fixtures can be repaired by replacing washers, but most newer fittings are washerless and eliminate future leaks from worn washers. If this does not improve the flow and the fitting is not repairable, replacement provides the opportunity for improved access and function (Refer to Section 5.3, Access and Safety).

ADVANTAGES: Inexpensive.

DISADVANTAGES: Some repairs may require professional service.

2. HIGH EFFICIENCY LOW-FLOW SHOWERHEAD.

Limiting devices can be installed behind an existing showerhead. Hansgrohe has a three-part device that reduces the quantity of water supplied by 20%, 30%, or 40%, depending on the configuration of the device's three parts. Showerheads that limit the outflow of water to 2.5 gpm or less need to compensate for pressure. Showerheads should have water pressure of 60 psi.

ADVANTAGES: Retrofit fittings in existing tub or shower.

DISADVANTAGES: Greater potential for scalding in low-flow showerheads with 2.0 gpm than the standard 3.0 gpm.

FURTHER READING

Bathroom Industry Technical Manual; Volume #3, Bathroom Equipment and Materials, Ellen M. Cheever, CKD, CBD, ASID, National Kitchen and Bath Association, 1997.

No Regrets Remodeling, Energy Auditor & Retrofitter, Inc., 1997.

"Water Resource Efficiency; The Performance Contracting Method," Thomas Horner, *ASPE Plumbing Engineer*, reprinted by Water Management, www.watermgt.com.

PRODUCT INFORMATION

Grohe, 241 Covington Dr., Bloomingdale, IL 60108; 630-582-7711; 630-582-7722 (fax); www.groheamerica.com.

Hansgrohe, 770-844-7414; 770-844-0236 (fax); www.hansgrohe-usa.com.

Resource Conservation, Inc., 39 Mapletree Ave., Stamford, CT 06906; 800-243-2862; 203-964-0600; 203-324-9352 (fax); www.resourcesconserv.com.

8

TOILETS & BIDETS

8.1

MAINTENANCE AND REPAIRS

ESSENTIAL KNOWLEDGE

Over time, toilets and bidets may be subject to cracks or chips in the surface of the fixture, or wear and tear of the mechanical devices that allow for smooth functioning. Disabled tank floats, stuck valves, and leaky connections are some of the most common maladies that require attention. Examining the existing condition of these fixtures is the first step in determining the rehab measures necessary to return them to good working order. Dirt and bacteria are often found in seams between the fixture and the floor and should be scoured. If fixtures need replacement, wall-hung fixtures are one way to eliminate such seams.

TECHNIQUES, MATERIALS, TOOLS

1. REPAIR VITREOUS CHINA SURFACE.

The most common surface material for toilets, bidets, and urinals is vitreous china—a high fired, non-porous, ceramic material with a high-gloss glaze. A ceramic-like epoxy from Abatron can be used to fill cracks or pits on the surface. The surface must first be cleaned and free of dust and debris. After an application of two or three coats, curing continues for up to two weeks. The hardening and curing process can be accelerated by applying heat around 200°F.

ADVANTAGES: The glass-like appearance is favored for its sanitary characteristics. Epoxy is effective on moist or wet surfaces, and ideal for small areas.

DISADVANTAGES: Refinishing the entire fixture is labor intensive and should be completed by a professional for a uniform appearance. Decals applied to the glaze will not be as durable if the fixture was not fired at a high enough temperature.

2. REPAIR WATER SEEPAGE.

Water seepage at the base of the toilet is likely a sign of a damaged wax ring gasket seal. Water under the base of the toilet can result in damage to floor finishes and subfloor. Remove as much water from the bowl as possible, disconnect the riser tube, and remove the reservoir tank from the toilet bowl. Brittle or cracked rubber washers and gaskets should be replaced. Unbolting the bowl from the floor will reveal the wax ring, which should be removed. Clean surfaces and insert a new ring.

ADVANTAGES: Saves floor and structure; conserves water.

DISADVANTAGES: Can be labor intensive.

3. REPAIR RUN-ON TOILET.

A run-on toilet can be caused by a faulty tankball, inlet valve, or float (Fig. 1). A rubber tankball controls water flow into the reservoir tank. The float (usually a large ball) rises and falls with the water level in the reservoir tank to control the inlet valve. The inlet valve opens as the float moves down. The float ball should resist any pressure to push it under water; if it remains partially submerged, it may be taking on water and should be replaced. If the water continues to run, the float arm or tankball rod can be adjusted by bending it down until the water shuts off. Leak savers are available from Resource Conservation that lock the float ball in the off position after every flush to stop the toilet from cycling on and off.

ADVANTAGES: Conserves water and can be an inexpensive repair.

DISADVANTAGES: Conditions that are not obvious may require repair by a professional.

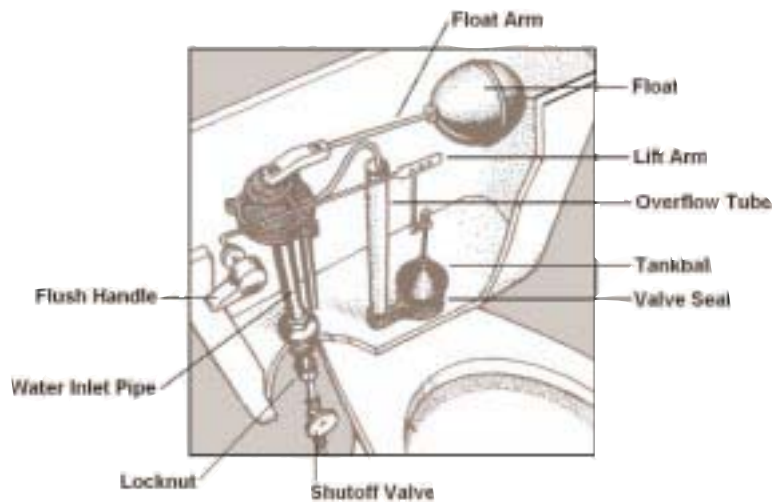

FIGURE 1

TOILET RESERVOIR TANK DETAIL

FURTHER READING

Bathroom Industry Technical Manual; Volume #3, Bathroom Equipment and Materials, Ellen Cheever, CKD, CBD, ASID, National Kitchen and Bath Association, 1997.

Home Improvement for Dummies, Gene and Katie Hamilton, IDG Books Worldwide, 1998.

PRODUCT INFORMATION

Abatron, Inc., 5501 95th Ave., Kenosha, WI 53144; 414-653-2000; 414-653-2019 (fax); www.abatron.com.

Resource Conservation, Inc., 39 Mapletree Ave., Stamford, CT 06906; 800-243-2862; 203-964-0600; 203-324-9352 (fax); www.resourcesconserv.com.

8.2

WATER CONSERVATION

ESSENTIAL KNOWLEDGE

Toilets more than 15 years old use between 5 and 7.5 gallons of water per flush (gpf); toilets manufactured after 1980 use 3.5 gpf. According to the Federal Energy Act of 1994, toilets manufactured today must use no more than 1.6 gpf and urinals no more than 1.0 gpf. Toilets are either gravity-assisted (relying on gravity to flush the bowl) or pressure-assisted (relying on gravity and a pressurized chamber to flush the bowl).

TECHNIQUES, MATERIALS, TOOLS

1. INSTALL WATER-LIMITING DEVICES.

Existing toilets that use 3.5 gpf can conserve water with a variety of devices. Resource Conservation offers stainless steel and vinyl panels that are placed in the tank to dam off a portion to limit the flow of water into the tank; the toilet flushes normally with less water. When the toilet is flushed, water directed into the overflow pipe refills the toilet bowl. In many toilets, water will continue to run into the bowl while the tank fills, although the bowl is full. Water then drains out of the bowl. The AquaSaver from The Fuller Group, and a similar device from Niagra Conservation Group, fills the tank faster, and the bowl slower, to reduce water drainage through a full bowl.

ADVANTAGES: Inexpensive and easy to install; short-term alternative to low-flow toilets.

DISADVANTAGES: Cannot be used in all toilets; devices do not compare to the long-term water savings of low-flow toilets.

2. INSTALL A GRAVITY-ASSISTED TOILET.

In gravity-assisted toilets, the pressure of the water rushing down the drain creates a vacuum or siphon effect that draws waste down with it. Clogs and backups can occur when there is not enough force to push waste through the 4" to 6" diameter pipe found in many older homes. The interior surface of cast iron pipes, found in many older homes, is rougher than plastic pipe. The vent, pressure level, piping size, bacteria build-up, or reverse pitches in the drain should be evaluated before installation. Vacuum-assisted technology was developed by Fluidmaster and is used in the Vacuity model manufactured by Briggs Industries. Two plastic tanks within the toilet tank hold 1.6 gallons; a vacuum is created when the tank is flushed that forces water into the bowl.

ADVANTAGES: Low-end to high-end models available; wide design choices.

DISADVANTAGES: Frequent need to double flush; streaks on the bowl and clogs are common.

3. PRESSURE-ASSISTED TOILETS.

Pressure-assisted toilets use water line pressure to increase flush velocity. Water is stored in a small pressure chamber inside the tank, and a pocket of air releases water at 25 psi into the bowl. Toilets with a Sloan Flushmate pressure-assisted tank include the American Standard Cadet, Crane Economiser, Eljer Aqua-Saver, Gerber Ultra Flush, Mansfield Quantum, and Universal Rundle Powerflush. Only specially designed toilets can accept pressure-assisted units. The technology for an adapter unit to convert gravity-assisted toilets to pressure-assisted fixtures has yet to be developed.

ADVANTAGES: Eliminates problems of incomplete flush.

DISADVANTAGES: Pressure assisted toilets are more costly and noisy. Limited styles and manufacturers.

4. INSTALL A WALL-HUNG URINAL.

To supplement an existing toilet, a wall-mounted urinal, such as a compact unit from MisterMiser (Fig. 2), can be installed between the wall studs in an existing bathroom. The urinal is rinsed with 10 ounces of water, activated when the lid is closed, which is far less than the 1.6 gpf needed to flush a new toilet.

ADVANTAGES: Saves cleanup, water, and space.

DISADVANTAGES: Cost is comparable with a high-end toilet.



FIGURE 2

WALL HUNG URINAL RETROFIT INTO WALL IN CLOSED AND OPEN POSITION

FURTHER READING

“Choosing a Toilet,” *Fine Homebuilding*, www.taunton.com.

“Flushing 1.6 gpf; How 1.6 gpf Technologies Impact Today’s Plumbing Conservation Goals,” Jose Baz, Sloan Valve Company.

“Less Wasteful Flushing,” *Environmental Building News*, Volume 8 Number 3, March 1999, www.ebuild.com.

“Remodeling Bathrooms; Let the Energy Savings Flow,” David Johnson, *Home Energy Magazine*, Reprint.

PRODUCT INFORMATION

Briggs Industries, 4350 W. Cypress Street, Tampa, FL 33607; 800-888-4458; 813-874-1394 (fax); www.briggsplumbing.com.

Sloan Flushmate, Sloan Valve Company, 10500 Seymour Ave., Franklin Park, IL 60131; 800-875-9116; 248-347-2782 (fax).

Grohe Built-in tank, 241 Covington Dr., Bloomingdale, IL 60108; 630-582-7711; 630-582-7722 (fax); www.groheamerica.com.

MisterMiser Urinal, 4901 N. 12th, Quincy, IL 62301; 888-228-6900; 217-228-6906 (fax); www.MisterMiser.com.

Niagra Conservation Corp., 45 Horsehill Rd., Cedar Knolls, NJ 07927; 800-831-8383; 201-829-1400 (fax).

Resource Conservation, Inc., 39 Mapletree Ave., Stamford, CT 06906; 800-243-2862; 203-964-0600; 203-324-9352 (fax); www.resourcesconserv.com.

The Fuller Group, 341 Summerford Court, Marietta, GA 30062; 770-650-8838; 770-565-4197 (fax); www.aquasaver.com.

8.3

MAXIMIZE ACCESS AND FUNCTION

ESSENTIAL KNOWLEDGE

A clear floor space of 48” x 48” is recommended in front of toilets and bidets, and a 15” minimum center-line clearance to the toilet or other fixtures should be maintained. From the fixture to a side wall, at least 18” should be maintained. A rehab project is an opportunity to apply universal design principles to improve access and flexibility.

TECHNIQUES, MATERIALS, TOOLS

Ideas to improve access to the toilet or bidet area:

1. INSTALL SPECIAL SEAT TO INCREASE SEAT HEIGHT.

Standard toilets have a height of 15” to the top of the seat; standing from a low seated position can be difficult for people with mobility impairments, back restraints, reduced strength, or joint conditions. Increasing the toilet seat height with special, thick seats or spacers that fit between the rim of the bowl and the seat can solve this problem.

ADVANTAGES: Flexible as needs change.

DISADVANTAGES: Institutional look.

2. INCREASE HEIGHT OF TOILET SEAT.

A raised base will elevate the toilet seat to a desirable 18". The base can be constructed of 2x4s. The existing drain line must be extended up to meet the fixture, and existing flooring material can be matched to cover the base (Fig. 3).

ADVANTAGES: Improves comfort and access.

DISADVANTAGES: May not be easy to access by small children.

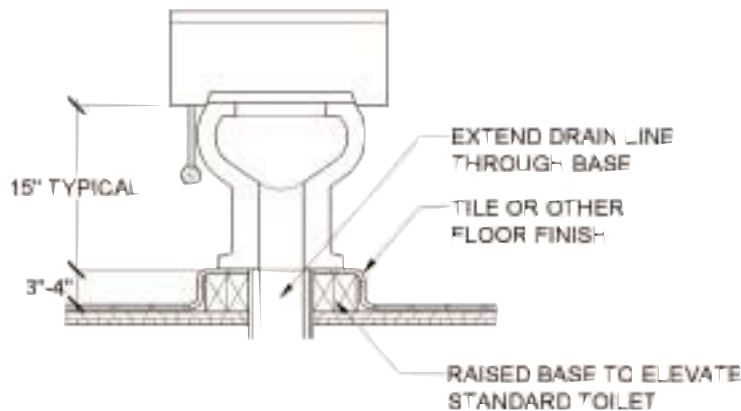

FIGURE 3

ELEVATED TOILET TO IMPROVE ACCESS

3. INSTALL BLOCKING FOR GRAB BAR.

Grab bars improve safety and stability; blocking should be installed on the walls surrounding the toilet and bidet so grab bars can be positioned where they will be most effective. A horizontal grab bar at least 42" long should be placed on at least one side wall at a height 33" to 36" above the floor. An optional grab bar may be located on the rear wall. In rehab work, with finished walls in place, grab bars can be added only where there are studs or if there is known blocking. When these options are not clear or not in the right location, a solid wood member (2x4 or 2x6) can be attached to the studs and the grab bars attach to it. Another solution, relatively new to the market, is the WingIt Grab Bar Fastening System from Pinnacle, which can be installed into substrates such as drywall to fasten grab bars to the wall.

ADVANTAGES: Improves access when needed. Reduces risk of slips and falling.

DISADVANTAGES: Future needs may change.

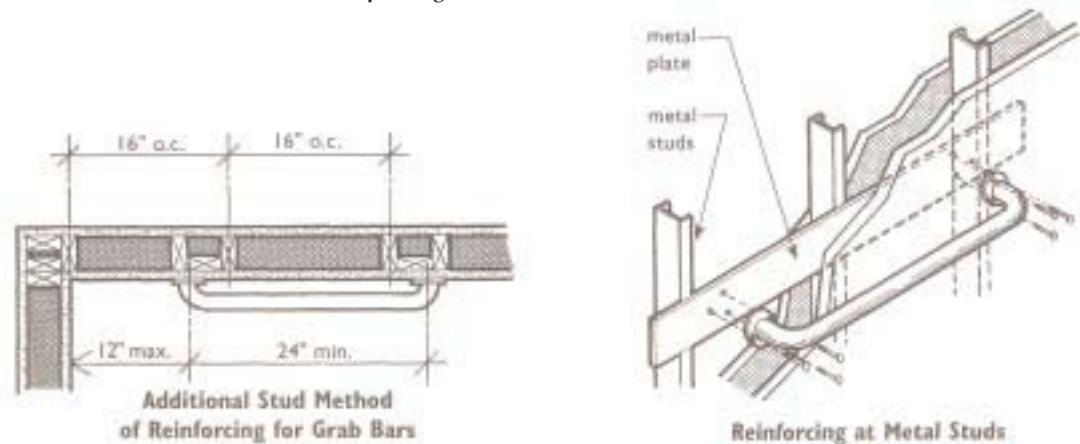

FIGURE 4

GRAB BAR AND BLOCKING DETAILS

4. INSTALL WALL-HUNG TOILETS AT DESIRED HEIGHT.

Concealed tank wall-hung toilets are mounted on the wall with the tank concealed in the wall. Pipes are not exposed, allowing for fast and easy cleaning. Wall-hung units can be installed on an existing wall, which must be at least 6" in depth. The flush actuator and access panel are horizontally mounted on a 6" wide ledge built in front of the existing wall. Height of the seat can be determined at installation.

ADVANTAGES: Insulation in the wall around the tank results in a quieter flush.

DISADVANTAGES: Access to the tank parts through a narrow access panel may be difficult.

5. INSTALL TOILET/BIDET COMBINATION.

While an existing bathroom might require considerable space, materials, and labor to add a bidet, it is possible to add a personal hygiene system within the existing toilet. Because a common challenge to an aging person is personal hygiene, this can be a valuable addition. Whether a separate fixture or an addition to the toilet, this system should be considered in every rehab bathroom project. The Geberit and Toto combination toilet and bidet converts to a bidet when a spray button is pressed. The rinsing spray arm retracts into a protected sleeve in the bowl after the spray button is released. Argenta and Lubidet offer an add-on bidet system for existing toilets.

ADVANTAGES: One fixture provides functions of toilet and bidet.

DISADVANTAGES: Air purifier and water heater add to energy use.

FURTHER READING

Bathroom Industry Technical Manual; Volume #3, Bathroom Equipment and Materials, Ellen Cheever, CKD CBD ASID, National Kitchen and Bath Association, 1997.

Universal Kitchen and Bath Planning, Mary Jo Peterson, CKD, CBD, CHE, McGraw-Hill, 1998.

PRODUCT INFORMATION

Argenta Trading and Consulting Corp., 7930 NW 36 St., Ste. 23-1351, Miami Springs, FL 33166; 888-462-4288; 305-883-1212; 305-883-1911 (fax).

Geberit Mfg., Inc., PO Box 2008, 1100 Boone Dr., Michigan City, IN 46360; 800-225-7217; 219-879-4466; 219-872-8003 (fax); www.geberit.com.

Hewi Inc., 2851 Old Tree Drive, Lancaster, PA 17603, 717-293-1313; 877-439-4462; 717-293-3270 (fax).

Lubidet, 1980 S. Quebec Street, Denver, CO 80231; 303-368-4555; 303-368-0812 (fax); www.lubidet.com.

Low Flow Plumbing Fixtures, Plumbing Manufacturers Institute (PMI); 708-858-9172; www.pmihome.org.

Otto Bock Rehab., 3000 Xenium Ln. Minneapolis, MN 55441; 800-328-4088; 612-553-9464; 612-519-6150; www.ottobock.com.

Pinnacle Innovations Inc., 8 Martin Ave., South River, NJ 08882; 732-257-6900; 732-257-6926 (fax); www.wingits.com.

Toto, 1150 Southern Road, Morrow, GA 30260; 770-282-8686; 770-968-8697 (fax); www.toto.com.

APPENDIX

PROFESSIONAL ASSOCIATIONS AND RESEARCH CENTERS

ADHESIVE AND SEALANT COUNCIL, INC.
7979 Old Georgetown Rd., Suite 500
Bethesda, MD 20814
301-986-9700
www.ascouncil.org

ADAPTIVE ENVIRONMENTS CENTER
374 Congress Street
Suite 301
Boston, MA 02210
617-695-1225
www.adaptenv.org

AMERICAN ASSOCIATION OF
RETIRED PERSONS
601 E Street, NW
Washington, DC 20049
800-424-3410
www.aarp.org

AMERICAN COUNCIL FOR
AN ENERGY-EFFICIENT ECONOMY
1001 Connecticut Ave. NW, #535
Washington, DC 20036
202-429-8873
www.aceee.org

AMERICAN INSTITUTE OF ARCHITECTS
1735 New York Ave, NW
Washington, DC 20006
202-626-7300
www.aia.org

AMERICAN LIGHTING ASSOCIATION
World Trade Center
Suite 10046
2050 Stemmons Freeway
Dallas, TX 75342
800-605-4448
www.americanlightingassoc.com

AMERICAN OCCUPATIONAL
THERAPY ASSOCIATION, INC.
1383 Piccard Drive
Rockville, MD 20850
301-652-2682
www.aota.org

AMERICAN NATIONAL STANDARDS INSTITUTE
11 West 42nd Street, 13th Floor
New York, NY 10036
212-642-4900
www.ansi.org

AMERICAN SOCIETY FOR TESTING
AND MATERIALS
100 Barr Harbor Drive
West Conshohocken, PA 19428
610-832-9500
www.astm.org

AMERICAN SOCIETY OF HEATING,
REFRIGERATING, AND AIR-CONDITIONING
ENGINEERS (ASHRAE)
1791 Tullie Circle, NE
Atlanta, GA 30329
404-636-8400
www.ashrae.org

AMERICAN SOCIETY OF INTERIOR DESIGNERS
608 Massachusetts Ave, NE
Washington, DC 20002
202-546-3480
www.asid.org

AMERICAN SOCIETY OF PLUMBING
ENGINEERS (ASPE)
3617 Thousand Oaks Blvd., #210
Westlake, CA 91362-3649
805-495-7120
www.aspe.org

ASSOCIATION OF HOME APPLIANCE
MANUFACTURERS
20 N., Wacker Drive
Chicago, IL 60606
312-984-5800
www.aham.org

CANADA MORTGAGE AND
HOUSING CORPORATION
Housing Information Center
700 Montreal Road
Ottawa, ON, Canada K1A 0P7
613-748-2367
www.cmhc-schl.gc.ca

CENTER FOR UNIVERSAL DESIGN
North Carolina State University
Box 8613
Raleigh, NC 27695
800-647-6777
www.design.ncsu.gov

CERAMIC TILE DISTRIBUTORS ASSOCIATION
80 Roosevelt Rd., Building C, Suite 20
Glen Ellyn, IL 60137
800-938-2832
www.ctdahome.org

CONSORTIUM FOR ENERGY EFFICIENCY
303 Congress Street, Suite 600
Boston, MA 02210
617-330-9755

COUNCIL OF AMERICAN BUILDING OFFICIALS
5203 Leesburg Pike, Suite 708 Falls Church, VA
22041
703-931-4533
www.intlcode.org

ELECTRIC POWER RESEARCH INSTITUTE
3412 Hillview Ave.
Palo Alto, CA 94303
800-313-3774
www.epri.com

FLOOR COVERING INSTALLATION
CONTRACTORS ASSOCIATION
PO Box 948
Dalton, GA 30722
706-226-5488
www.fcica.com

GAS APPLIANCE MANUFACTURERS
ASSOCIATION
1901 North Moore Street, Suite 1100
Arlington, VA 22209
703-525-9565
www.gamanet.org

GAS RESEARCH INSTITUTE
8600 Bryn Mawr Ave.
Chicago, IL 60631
312-399-8100
www.gri.org

HARDWOOD MANUFACTURERS ASSOCIATION
400 Penn Center Blvd., Suite 530
Pittsburgh, PA 15235
412-829-0844
www.hardwood.org

HOME ENERGY RATING SYSTEMS COUNCIL
1331 H St., NW, Suite 1000
Washington, DC 20005
202-638-3700
www.hers-council.org

HUD USER
P.O. Box 6091
Rockville, MD 20849
800-245-2691
www.huduser.org

IDEA CENTER
University of Buffalo
Buffalo, NY 14214
716-829-3485, Ext. 329
www.arch.buffalo.gov/idea

INTERNATIONAL CAST POLYMER ASSOCIATION
8201 Greensboro Dr., Suite 300
McLean, VA 22102
703-610-9005
www.icpa-hq.com

INTERNATIONAL INTERIOR DESIGN
ASSOCIATION
341 Merchandise Mart
Chicago, IL 60654
312-467-1950
www.iida.org

INTERNATIONAL REMODELING CONTRACTORS
ASSOCIATION
1 Regency Drive
Bloomfield, CT 06002
800-937-4722

ITALIAN TRADE COMMISSION
Tile Department
499 Park Avenue
New York, New York 10022
212-980-1500
www.italtrade.com

KITCHEN CABINET MANUFACTURERS
ASSOCIATION
1899 Preston White Drive, Reston, VA 22091
703-264-1690
www.kcma.org

LAMINATING MATERIALS ASSOCIATION
116 Lawrence Street
Hillsdale, NJ 07642
201-664-2700

MARBLE INSTITUTE OF AMERICA
30 Eden Alley, Suite 301
Columbus, OH 43215
614-228-6194
www.marble-institute.com

NAHB REMODELERS COUNCIL
1201 15th Street, NW
Washington, DC 20005
202-822-0212
www.nahb.com/remodelc.html

NATIONAL ASSOCIATION OF ARCHITECTURAL
METAL MANUFACTURERS
8 S. Michigan Ave., Suite 1000
Chicago, IL 60603-3305
312-456-5590

NATIONAL ASSOCIATION OF HOME BUILDERS
1201 15th Street, NW
Washington, DC 20005
800-368-5242
www.nahb.com

NATIONAL ASSOCIATION OF PLUMBING
HEATING AND COOLING CONTRACTORS
180 S. Washington Street
P.O. Box 6808
Falls Church, VA 22040
800-533-7694
www.naphcc.org

NATIONAL ASSOCIATION OF THE REMODELING
INDUSTRY
4900 Seminary Road, Suite 320
Arlington, VA 22311
703-575-1100
www.nari.org

NATIONAL KITCHEN AND BATH ASSOCIATION
687 Willow Grove Street
Hackettstown, NJ 07840
800-843-6522
908-852-0003
www.nkba.org

NATIONAL OAK FLOORING MANUFACTURERS
ASSOCIATION
Box 3009
Memphis, TN 38173
901-526-5016
www.nofma.org

NATIONAL PROPANE GAS ASSOCIATION
1600 Eisenhower Lane, Suite 100
Lisle, IL 60532
708-515-0600
www.propanegas.com

NATIONAL RENEWABLE ENERGY LABORATORY
1617 Cole Boulevard
Golden, CO 80401
303-275-3000

PLUMBING MANUFACTURER'S INSTITUTE
800 Roosevelt Road
Building C, Suite 20
Glen Ellyn, IL 60137
630-858-9172
www.pmihome.org

TILE COUNCIL OF AMERICA
100 Clemson Research, Blvd.
Anderson, SC 29625
864-646-8453
www.tileusa.com

TRACE RESEARCH & DEVELOPMENT CENTER
5901 Reseach Park Blvd.
Madison, WI 53719
608-262-6966
www.trace.wisc.edu

UNDERWRITERS LABORATORIES, INC.
333 Pflingsten Road
Northbrook, IL 60062-2096
847-272-8800
www.ul.com

U.S. DEPARTMENT OF ENERGY
Building Systems and Materials Division,
EE-421
1000 Independence Avenue, SW
Washington, DC 20585
202 586 9214
www.doe.gov

U.S. DEPARTMENT OF ENERGY'S
ENERGY EFFICIENCY AND RENEWABLE ENERGY
NETWORK, EREN
www.eren.doe.gov

U.S. DEPARTMENT OF ENERGY'S
ENERGY EFFICIENCY AND RENEWABLE ENERGY
CLEARINGHOUSE, EREC
P.O. Box 3048
Merrifield, VA 22116
800-363-3732
www.eren.doe.gov/erec/

U.S. DEPARTMENT OF HOUSING AND URBAN
DEVELOPMENT
451 Seventh Street, SW
Washington, DC 20410-6000
www.hud.gov

WOOD MOULDING AND MILLWORK
PRODUCERS ASSOCIATION
507 First Street
Woodland, CA 95695
www.wmmpa.com

THE REHAB GUIDE

VOLUME ONE: FOUNDATIONS

VOLUME TWO: EXTERIOR WALLS

VOLUME THREE: ROOFS

VOLUME FOUR: WINDOWS AND DOORS

VOLUME FIVE: PARTITIONS, CEILINGS, FLOORS AND STAIRS

VOLUME SIX: KITCHENS & BATHS

VOLUME SEVEN: ELECTRICAL/ELECTRONICS

VOLUME EIGHT: HVAC/PLUMBING

VOLUME NINE: SITE WORK

U.S. Department of Housing and Urban Development
Washington, DC 20410-6000

Official Business
Penalty for Private Use, \$300

September 1999
HUD-DU100C000005956

