

VOL 7



THE REHAB GUIDE

1 IN.

ELECTRICAL/ELECTRONICS



PATH (Partnership for Advancing Technology in Housing) is a new private/public effort to develop, demonstrate, and gain widespread market acceptance for the “Next Generation” of American housing. Through the use of new or innovative technologies the goal of PATH is to improve the quality, durability, environmental efficiency, and affordability of tomorrow’s homes.

Initiated at the request of the White House, PATH is managed and supported by the Department of Housing and Urban Development (HUD). In addition, all Federal Agencies that engage in housing research and technology development are PATH Partners, including the Departments of Energy and Commerce, as well as the Environmental Protection Agency (EPA) and the Federal Emergency Management Agency (FEMA). State and local governments and other participants from the public sector are also partners in PATH. Product manufacturers, home builders, insurance companies, and lenders represent private industry in the PATH partnership.

To learn more about PATH, please contact:

PATH
Suite B 133
451 7th Street SW
Washington, DC 20410
202-708-4250 (fax)
e-mail: pathnet@pathnet.org
website: www.pathnet.org

DISCLAIMER

The statements and conclusions contained in this report are those of Steven Winter Associates, Inc. and do not necessarily reflect the views of the Department of Housing and Urban Development. Steven Winter Associates, Inc. has made every effort to verify the accuracy and appropriateness of the report’s content. However, no guarantee of the accuracy or completeness of the information or acceptability for compliance with any industry standard or mandatory requirement of any code, law, or regulation is either offered or implied. The products listed in the report are included only as examples of some available products. No endorsement, recommendation, or evaluation of these products or their use is given or implied.

ELECTRICAL/ ELECTRONICS

VOLUME 7 OF THE REHAB GUIDE

TABLE OF CONTENTS

FOREWORD **3**

1. INTRODUCTION **4**
2. ELECTRICAL/ELECTRONICS OVERVIEW **6**
3. SERVICE PANELS **8**
4. WIRING & RECEPTACLES **14**
5. LIGHTING & CONTROLS **21**
6. ELECTRIC BASEBOARD HEATING **30**
7. PHONE/COMPUTER/TV CABLING **33**
8. SECURITY SYSTEMS **36**

APPENDIX: PROFESSIONAL ASSOCIATIONS & RESEARCH CENTERS **52**

Prepared for:
U.S. Department of Housing
and Urban Development
Office of Policy Development
and Research

Prepared by:
Steven Winter Associates, Inc.
Building Systems Consultants
Norwalk, CT

Contract DUIOOC000005956
April 2000

CREDITS

STEVEN WINTER ASSOCIATES, INC. STAFF MEMBERS
WHO WERE INSTRUMENTAL IN THE DEVELOPMENT AND
PRODUCTION OF THIS GUIDEBOOK INCLUDE:

Steven Winter
Principal-in-charge

Michael J. Crosbie, Ph.D., RA
Editor-in-chief and project manager

Masaki Furukawa
Illustrator

Christopher Demeter, Christoph Weigel, Jeff A. Goldberg, Pawan Kumar
Project team members

U.S. DEPARTMENT OF HOUSING AND URBAN DEVELOPMENT
OFFICE OF POLICY DEVELOPMENT AND RESEARCH, AFFORDABLE
HOUSING RESEARCH AND TECHNOLOGY DIVISION

David Engel
Director

Nelson Carbonell
Senior architect

GUIDEBOOK DESIGN

Andrew P. Kner
Art Director

Michele L. Trombley
Assistant Art Director

Elizabeth Rosen
Symbols

FOREWORD

President Clinton recognizes that research and technological innovation are crucial if America is to meet its affordable housing needs. In 1998, the President introduced a major new initiative: The Partnership for Advancing Technology in Housing (PATH). This initiative brings together leaders from the home building, product manufacturing, insurance, and financial industries, as well as representatives from federal agencies, to spur housing design and construction innovations.

Thanks to the development of new machinery and materials and the creation of new technologies and techniques, the construction industry has made great progress. But a breakthrough material, a labor-saving tool, or a cost-cutting technique is only valuable if it is widely adopted, which means the construction industry must first become aware of these new developments.

The Department of Housing and Urban Development can help. We have commissioned a set of guidebooks that will present state-of-the-art techniques, materials, and technologies for housing rehabilitation. This volume, *Electrical/Electronics*, is the seventh of nine guidebooks—known collectively as *The Rehab Guide*.

We are presenting these guidebooks because, like research and technological innovation, housing rehabilitation is an essential component of America's commitment to provide affordable housing. I am pleased to present this important publication in the hope that it will become a valuable resource that leads to affordable, high quality rehabilitation, and thus to better housing for all Americans.

A handwritten signature in black ink, appearing to read "Andrew Cuomo". The signature is fluid and cursive, with a large, sweeping flourish at the end.

Andrew Cuomo, Secretary
U.S. Department of Housing and Urban Development

INTRODUCTION

This series of guidebooks has been produced by the U.S. Department of Housing and Urban Development to keep the design and construction industry abreast of innovations and state-of-the-art practices in home rehabilitation. As is too often the case, innovative techniques, materials, technologies, and products are slow to make their way into accepted practice. It is evident that such innovations will not advance unless the industry is made aware of them and they are tested. *The Rehab Guide* is intended to accelerate this process by informing builders, architects, engineers, and other housing rehabilitation professionals about such innovations and state-of-the-art practices.

The Rehab Guide was also prompted by the lack of a comprehensive publication to make the design and construction industry aware of innovative and cost-saving developments in housing rehabilitation. Professional trade magazines, conferences, and trade shows offer some dissemination of this information, but they are rarely focused exclusively on housing rehabilitation, as this series is, nor are they comprehensive.

The focus of this series is on housing rehabilitation, which is different than home improvement. Rehabilitate means “to restore to good condition,” not necessarily to improve to a state that is significantly different than the original. This is a fine line, but it distinguishes this series from “home improvement” books written for the amateur. *The Rehab Guide* focuses on building technology, materials, components, and techniques rather than “projects” such as adding a new room, converting a garage into a den, or finishing an attic. Nor is *The Rehab Guide* intended to be a “diagnostic” tool; a number of such books are already available to the industry.

The content for this guidebook, *Electrical/Electronics*, has been gathered from professionals in the housing rehabilitation field; manufacturers and suppliers of innovative technologies, materials, components, tools, and equipment; trade shows, conferences, reports, and publications considering such issues; trade organizations; and building research centers.

A NOTE ON SOURCES

A variety of excellent resources exists for information on electrical and electronics for homes. *Old Electrical Wiring*, published by McGraw-Hill, is an excellent book on wiring in existing homes and includes historical information and a resource section. *Basic Wiring* and *Advanced Wiring*, both published by Time-Life Books; *Practical Electrical Wiring*, published by McGraw-Hill; and *Wiring a House*, published by Taunton Press, are all comprehensive guides to wiring a house. The *Old-House Journal Guide to Restoration*, published by Dutton, provides a good history of wiring systems and tips for repair. Monthly publications of interest include the *Energy Design Update*, *Environmental Building News*, *Journal of Light Construction*, *Home Energy*, *Old-House Journal*, *This Old House*, and *Traditional Builder*.

Helpful information is also accessible via the Internet. Most equipment manufacturers and monthly magazines have web sites where specific product information and past articles can be retrieved. The Department of Energy provides a wealth of information on energy conserving techniques and technologies at www.eren.doe.gov/consumerinfo/.

LEAD PAINT HAZARD

The hazard of lead paint in houses constructed before the 1980s is not discussed in the *The Rehab Guide* because there is extensive material available from HUD, the Environmental Protection Agency (EPA), and other sources. However, if you are a non-profit or rehab contractor rehabilitating pre-1978 housing for sale or rent, or if you are a homeowner rehabilitating a home for your own use, you are strongly urged to have the home tested for lead paint. This is especially critical if the home will be occupied by young children. Very small amounts of lead in paint or dust can poison children if swallowed or inhaled, causing

damage to the brain and other organs, resulting in health problems and reduced intelligence. If lead paint is found, it is critical that all rehabilitation be done very carefully to reduce the possibility of lead poisoning to you or your workers. Proper work practices will minimize the risk of spreading lead contamination and increasing occupant exposure.

One of the best and most recent sources on this subject is the HUD publication, *Lead Paint Safety: a Field Guide for Painting, Home Maintenance, and Renovation Work*. Another good publication is the EPA brochure, “Reducing Lead Hazards When Remodeling Your Home.” Both can be obtained by calling the National Lead Information Center at 800-424-LEAD or by downloading from the web site of the HUD Office of Lead Hazard Control, www.hud.gov/lea. A very comprehensive source is the HUD publication, *Guidelines for the Evaluation and Control of Lead-Based Paint Hazards in Housing*, which gives guidance on controlling lead hazards, lead paint and rehab work, risk assessment, monitoring, inspections, resident and work site preparation, worker protection, and routine building maintenance. This publication is available through HUD-User; you can also download a copy of this document from the HUD web site at: www.hud.gov:80/lea/learules.html.

HUD has new regulations on lead-based paint hazards in federally owned housing and housing receiving federal assistance. If you will be using HUD funds for rehabilitation through grants, insurance, or other types of assistance, then there are protective procedures that must be followed. The Occupational Safety and Health Administration web site at www.osha.gov has information on worker protection requirements. In addition, many states and localities have their own rules regarding lead-based paint, which should be followed when undertaking rehabilitation.

HOW THE GUIDE IS ORGANIZED

Nine volumes make up *The Rehab Guide* in its entirety, and they are listed on the back cover of this volume. Each one is devoted to distinct elements of the house, and within each volume is a range of issues that are common to that element of home rehabilitation work. This volume covers topics from repair of existing light fixtures to fixing or replacement existing wiring, retrofitting for telephone/television/computer cabling, and security systems. Each volume addresses a wide range of techniques, materials, and tools, with recommendations based on regional differences around the country. Throughout *The Rehab Guide*, special attention is given to issues related to energy efficiency, accessible design, and sustainability.

The Rehab Guide is written and presented in a format intended for easy use. The spiral bound volumes open flat so that they can be easily photocopied, and they can be assembled and stored in a single three-ring binder. Within each volume, drawings, photos, and other graphic materials supplement written descriptions of a broad range of items: state-of-the-art and innovative building technology, products, materials, components, construction and management techniques, tools, equipment, software—virtually any and all items that make housing rehabilitation more efficient in terms of cost and time. While the content focuses on present technologies and techniques that are currently part of the house-building industry, *The Rehab Guide* also includes information on materials, products, and procedures from other construction sectors (such as commercial, industrial, institutional) that are relevant to housing rehabilitation.

The information is organized in different sections according to rehab subjects, and under headings that make this book easy to understand. “Essential Knowledge” gives the reader a basic overview of the important issues related to the section heading. Next, “Techniques, Materials, Tools” presents state-of-the-art and innovative approaches to accomplishing the work. Each entry is explained in detail, including its advantages and disadvantages. This makes it easy for readers to compare approaches and choose the one that is most applicable to their particular project. By design, the “Techniques, Materials, Tools” section is an overview, not a detailed description of implementation. “Further Reading” lists the valuable resources relevant to the subject that readers can go to for more detailed information. Finally, “Product Information” provides names and addresses of manufacturers of products, materials, systems, and components mentioned in the text so that more information can be obtained. By virtue of their being listed here, such products are not necessarily being recommended; their existence and availability are being brought to the reader’s attention. New products should be carefully evaluated in the field as to their performance. The product lists are not necessarily comprehensive, and we encourage readers to bring new materials and products to our attention to be included in later editions of *The Rehab Guide*.

2

ELECTRICAL/ ELECTRONICS OVERVIEW

ESSENTIAL KNOWLEDGE

Electrical systems that distribute power within a house must be safe, reliable, and efficient in the utilization of power. Defects in the performance of the system can result in damage to sensitive electronic equipment, electrical shocks, or fire. Recent studies by the Consumer Product Safety Commission reveal that fires of an electrical origin damage more than 400 homes a day, sometimes causing injury or death. Electronic detection devices such as carbon monoxide and smoke detectors are also important parts of the electrical system, and must be reliable to warn house occupants of hazardous conditions.

This guide will provide an overview and a reference resource for information about electrical/electronic systems, subsystems, and materials; a review of current theory in terms of performance of these systems; a discussion of new materials, techniques, or components that have recently been improved or that represent totally new product lines; and state-of-the-art practice and new standards in cabling for telephones, television, and computers. Because it is primarily about rehabilitation, this guide will cover retrofitting electrical systems to protect against hazardous situations. It will address problems with receptacles and controls to wiring and light fixtures to security and detection devices.

In comparison with other house systems, such as framing or plumbing, the electrical system is relatively new. From their infancy in homes a little over 100 years ago, electrical systems and materials have gone through significant transformations, all of which have contributed to improved safety. Most new product developments today are in low voltage wiring for electronics, communications, and control systems.

Because the electrical system in a home is old does not mean it needs to be replaced. Most older electrical systems or components of the system are “grandfathered” in, permitted to remain in place and continue to operate, unless the electrical inspector believes them to be unsafe. In remodeling, the general rule of thumb is: if it is touched, it must be brought up to code.

Before beginning any electrical work, consult the National Electric Code (NEC), local building codes, and the local building code official. The NEC, first developed in 1897, is a model set of electrical safety requirements published by the National Fire Protection Association (NFPA) for building and insurance inspectors and electrical contractors. It has no legal standing of its own. Most towns or jurisdictions simply adopt it, and are free to interpret or enforce it as they see fit. Some localities also add their own electrical code requirements.

One of the requirements often found in the NEC is that appliances or equipment on an electrical circuit be “listed.” This means that the device has been certified by an independent testing laboratory. The function of an independent testing laboratory, such as Underwriter’s Laboratory (UL), is to perform tests on a product to make sure that it fulfills the manufacturer’s claims and that it is safe. Without certification, an installation may not pass the electrical inspection. In this case the field inspection service of a Nationally Recognized Testing Laboratory (NRTL) can perform a single unit investigation and certify the product.

FURTHER READING

- Caring for Your Historic House*, Harriet Whelchel editor, Heritage Preservation, 1998.
- A Consumer's Guide to Home Improvement, Renovation, and Repair*, Enterprise Foundation, New York: John Wiley & Sons, Inc. 1990.
- The Guide to Low-Voltage and Limited Energy Systems*, National Electrical Contractors Association, 1999.
- Home Repair and Improvement - Advanced Wiring*, the editors of Time-Life Books, Alexandria, VA: Time-Life, 1998.
- Home Repair and Improvement - Basic Wiring*, the editors of Time-Life Books, Alexandria, VA: Time-Life, 1994.
- Landfield Group archive of publicly available material: www.landfield.com.
- National Electrical Code 1999*, National Fire Protection Association, 1998.
- Old Electrical Wiring Maintenance and Retrofit*, David E. Shapiro, New York: McGraw-Hill, 1998.
- The Old-House Journal Guide to Restoration*, Patricia Poore, editor, New York: Dutton, 1992.
- Practical Electrical Wiring, 17th Edition*, Herbert P. Richter and W.Creighton Schwan, New York: McGraw-Hill Book Company, 1996.
- Renovating Old Houses*, George Nash, Newtown, CT: Taunton Press, 1992.
- Troubleshooting Guide to Residential Construction*, the editors of the *Journal of Light Construction*, Builderburg Group, Inc., 1997.
- Understanding and Servicing Alarm Systems*, Second Edition, H. William Trimmer, B.S., Butterworth Heinemann, 1989.
- Wiring a House*, Rex Cauldwell, Newtown, CT: Taunton Press, 1996.

3

SERVICE PANELS

ESSENTIAL KNOWLEDGE

A residential service panel serves two functions. It is a master switch that can cut off all of the power in the house, and it divides utility-supplied electrical power into branch circuits, which safely distribute power throughout a house. The wiring of each branch circuit is protected by a fuse or circuit breaker, which cuts off the power when a circuit is overloaded. Without adequate protection, overloaded wires heat up. This damages the wire's insulation and may eventually lead to a fire. The National Electrical Code (NEC) lists the specific fuse/breaker size and the wire gauge that it is meant to protect. For example, 12 and 14 gauge wire, which are commonly found in residences, require over-current protection of 20- and 15-amps, respectively.

There are several causes of circuit overloads. They may result from short circuits, ground faults, or appliances drawing more current than the rating of the fuse/circuit breaker (Figs.1, 2). A direct short circuit occurs when the hot and neutral wires are either directly or indirectly touching. A nail driven into the wires would cause this type of short circuit. A ground fault occurs when a hot wire touches a ground wire. An example is if the hot wire accidentally touches the grounded frame of a tool or appliance.

A fuse uses a fusible link to protect the circuit. When overloaded the fusible link melts, opening up the circuit. There are two types of fuses: cartridge fuses and plug fuses. Cartridge fuses, which are no longer common in residences, can still be found in older homes. Circuit breakers use a two-part system to protect the circuit. For mild overloads, a bimetal strip heats up, bends backwards, and eventually trips the breaker. For severe short circuits an electromagnet helps bend the strip faster, providing an almost instantaneous response to the open circuit. In general, the higher the current, the faster the breaker trips.

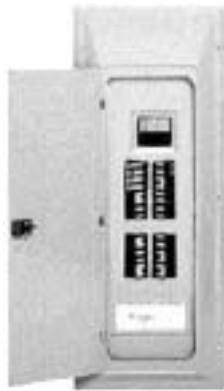

CIRCUIT BREAKER PANEL

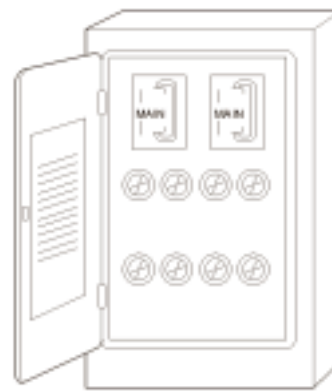

FUSE BOX

FIGURE 1, 2

Whereas standard circuit breakers and fuses are meant to protect the wiring of a house, the ground fault circuit interrupter (GFCI) is meant to protect life. There are two types of GFCIs available: circuit breakers and receptacles. The circuit breaker type (Fig. 3) was first introduced around 1968, which coincides with the year they were required by the NEC for underwater pool lights. Since then, the NEC has gradually required their use in more and more locations until today, where they are generally required in kitchens, bathrooms, garages, outdoors, and unfinished basements or crawlspaces (Fig. 4). A GFCI works by monitoring the current going to the load and comparing it with the current returning. If there is a difference between the two (up to four to six thousandths of an amp), current must be leaking out and the



GFCI CIRCUIT BREAKER



GFCI RECEPTICLE

FIGURE 3, 4

GFCI will open the circuit. Therefore, if this leak is to the ground through a person holding a tool or appliance, the GFCI will open the circuit in between 1/25 and 1/30 of a second. A person may still receive a shock, but it will last less than 1/30 of a second.

Until the late-1950s, fuse boxes dominated the residential service panel market. Circuit breaker panels were introduced around 1951 and became more popular, and by the 1960s circuit breaker panels surpassed fuse boxes in market share. Today, new residential fuse panels are difficult if not impossible to find.

Service panels of older homes are often overloaded and require a service upgrade. Due to the increasing number of electrical devices used in today's households, electrical demands have steadily increased. In the early 1900s houses were usually equipped with 15-amp and 20-amp services. As electrical appliances became household necessities in the 1930s and '40s, 40-amp and 60-amp service became common. Today 100-amp service is the minimum required by code for new construction. Generally, if the existing service in a home is below 100 amps and additional circuits are required, the service will have to be upgraded. This is especially true if the service to the house and panel are 120-volt, which cannot support an appliance requiring a 240-volt line, such as a clothes dryer.

The service disconnect indicates the size of the existing service. If there is no service disconnect, a licensed electrician will have to determine the service by verifying the size of the service entrance wire and the rating of the panel itself. Signs that may indicate an overloaded service panel include a frequently failing main fuse or circuit breaker; no room left in the service panel for additional circuits; dual or half-size breakers installed where they shouldn't be; two or more hot wires (each representing a circuit) connected to one fuse/breaker. Fuses that exceed the maximum amperage allowed (15-amp fuses replaced with 30-amp fuses) or lights dimming when such equipment as the furnace motor or refrigerator compressor turns on may also indicate an overloaded service panel or circuit. However, the best way to determine whether the existing service panel or circuit is overloaded is to calculate the electrical loads according to NEC guidelines.

Loose connections and corrosion are other common problems found in service panels that may require panel replacement. Corrosion can be a result of rain water entering the service panel by traveling along the service entrance cable (Fig. 5), or from the service panel being in a damp location. A drip loop or conduit weatherhead, along with proper sealants, will stop the former problem. The latter may require eliminating the source of moisture or relocating the service panel. Corrosion negatively affects the performance of fuses and circuit breakers. Corroded fuse connections allow only partial voltage to be available to a circuit. Corroded circuit breakers create a fire hazard by increasing the amount of current required to trip a breaker. Loose fuse and circuit breaker connections also create a fire hazard by causing arcing, burning, and overheating of the over current protection device, and sometimes the entire service panel. The smell of burnt insulation, a deformed bus bar, or the presence of heat can alert you to the presence of loose connections in the service panel.

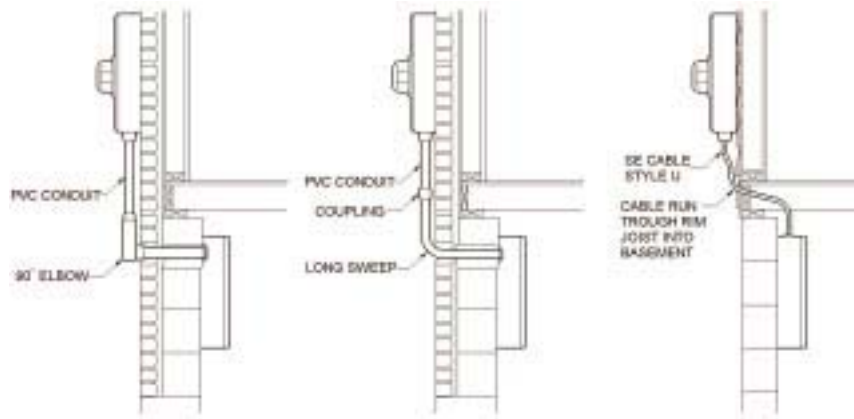

FIGURE 5 SERVICE ENTRANCE CONFIGURATIONS

TECHNIQUES, MATERIALS, TOOLS

1. INSTALL NEW PANEL WITH GREATER CAPACITY.

Installing a new service panel of greater amperage is the best, if not the only, practical solution available when the existing service panel is overloaded and the service needs to be increased. Where the existing panel is not overloaded but needs replacement, a larger panel should be considered, especially if future plans may require a service upgrade. To upgrade the power, an electrical construction permit will be required and the power company will have to be notified. The power company will remove the old meter before the old distribution panel is taken out, and restore power after the new panel is installed and has been inspected. In addition to a new service panel, the electric meter, weatherhead or underground connection, and the cable, conduit, and wire that link these service components will also have to be upgraded.

ADVANTAGES: Provides ample power for present and future needs.

DISADVANTAGES: A costly solution because of a combination of labor, materials, and permitting fees.

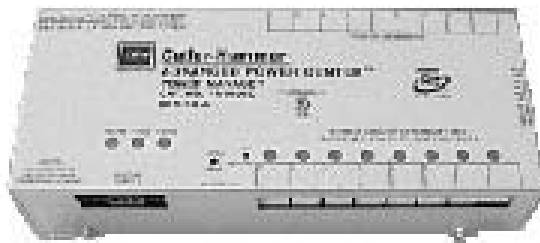

FIGURE 6 HOME AUTOMATION PANEL

2. INSTALL A HOME AUTOMATION-READY SERVICE PANEL.

When a service panel needs replacement, a panel with provisions for a home automation system (Fig. 6) can be installed. Such systems centralize the control of many electrical elements, including security, lighting, and communication. They also allow the homeowner to take advantage of incentives provided by the energy supplier by monitoring and controlling energy use. For example, electric hot water heaters and air conditioners can be shut off when no one is home. Home automation systems start at around \$2,000. For more information contact Cutler-Hammer about its Advanced Power Center™ Systems.

ADVANTAGES: A home automation-ready service panel provides future flexibility at only a slightly higher cost than a standard load center.

DISADVANTAGES: It is questionable whether real economic benefits now exist for installing a home automation system.

3. INSTALL A NEW PANEL WITH SAME CAPACITY BUT MORE CIRCUITS.

Generally speaking, residential service panels are available with anywhere from 8 to 40 circuits. Often, service panels will seem fully loaded because all the circuits are full. This is not always the case. If, after calculating the house loads, there is still electrical capacity available, it may be possible to replace the existing service panel with a new panel containing more circuits but with the same rating.

ADVANTAGES: Less costly than installing a higher rated service panel because less labor and fewer materials are required. A construction permit may not be required because the work is considered a repair.

DISADVANTAGES: This is an option only if service panel has additional capacity. This solution may not provide adequate capacity for increased electrical demands in the future.

4. INSTALL A SUBPANEL.

This is usually used when bringing electricity to a remote location on a house or property. It can also be used to add more circuits to a service panel (Fig. 7). For instance, because fuse panels rarely have room for additional circuits, more circuits can be added by placing a subpanel next to the main fuse box. Before adding a subpanel, loads must be calculated to make sure that the main panel will not be overloaded by the additional circuits added. A typical subpanel is fed from the main panel with a service entrance style “R” (SER) or round cable and contains breaker positions for two to six circuits. The installation of a subpanel may require approval by an electrical inspector prior to connecting the feeder to the main panel.

ADVANTAGES: For remote wiring applications, it is easier to connect new circuits to a subpanel than to run them back to the main distribution panel. When additional circuits are required, it is also easier to install a subpanel next to the main panel than to install a new service panel with more circuits, but the same rating.

DISADVANTAGES: SER cable is costly and may outweigh the cost of labor to run multiple circuit branch wires to the main service panel. Additionally, SER cable may be hard to find. This option is not available if the service panel is already at full electrical capacity.

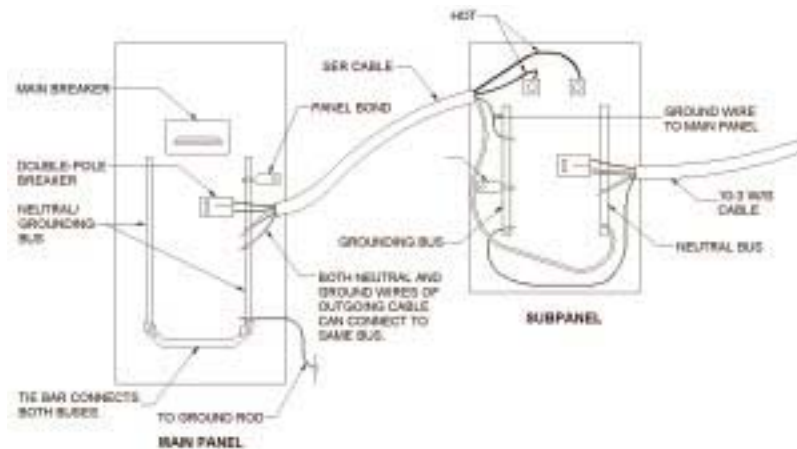

FIGURE 7

INSTALLING A SUBPANEL

5. INSTALL A DUAL OR HALF-SIZED BREAKER.

In older homes, it is often necessary to add additional outlets in rooms such as the kitchen for convenience and safety. As a result an additional circuit may be needed to accommodate these new outlets. If there is no room in the service panel for additional circuits, a dual or two half-sized breakers may be used to replace a full-sized single-pole breaker (Fig. 8). This is only possible if the existing service panel is designed to accommodate dual or half-sized breakers. Altering the panel to accommodate dual and half-sized breakers where they are not supposed to be is not only a code violation, but also a fire hazard.

ADVANTAGES: Easiest and least costly way to add additional circuits to a service panel.

DISADVANTAGES: Not all service panels are designed to accommodate dual and half-sized breakers. Because of their small size these breakers can be difficult to install. This option is not available if the service panel is already at full electrical capacity.

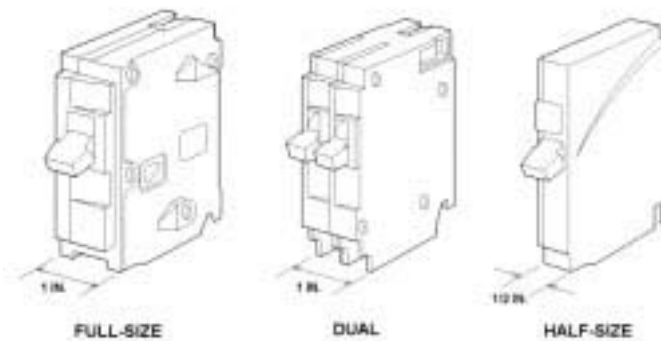

FIGURE 8

SINGLE-POLE CIRCUIT BREAKERS

6. INSTALL "TYPE S" ADAPTERS IN EXISTING FUSE SOCKETS.

Although the code does not require Type S fuses to be used for existing fuse boxes, it should be considered. All Edison-base fuses up to 30 amps are interchangeable. Therefore, nothing prevents a homeowner from substituting a 30-amp fuse for the 15-amp fuse that should be used. This defeats the purpose of the fuse and presents a severe fire hazard. To prevent overfusing, Type S fuses were developed. These fuses can only be used with adapters that are screwed into an ordinary Edison-base fuse holder. The 15-amp adapter accepts only a 15-amp fuse or smaller. Once these adapters are installed, they cannot be removed without damaging the fuse holder.

ADVANTAGES: The use of Type S fuse adapter makes it nearly impossible to overfuse a circuit, and thus significantly reduces the risk of fire.

DISADVANTAGES: Proper installation of Type S fuses requires that they be turned firmly to flatten out the spring under the shoulder of the fuses to make proper contact.

7. INSTALL GROUND FAULT CIRCUIT BREAKER

Replacing circuit breakers in good working order with GFCI circuit breakers is not required by most codes. However, because of the protection they provide, they should be installed in locations specified by the NEC. There are electrical devices that should not be protected by GFCIs, such as lighting, because a tripped circuit would leave a room dark. Freezers, refrigerators, sump pumps, and medical equipment are



FIGURE 9

AFCI CIRCUIT BREAKER

others. Even though the cost of a GFCI circuit breaker 2 is about seven times the cost of a standard breaker, most people would agree that this is a small price to pay for a device that may save a life.

ADVANTAGES: A GFCI circuit breaker will protect all receptacles on a circuit. For outdoor circuits, a circuit breaker-type GFCI will outlast a receptacle-type, which is affected by moisture.

DISADVANTAGES: Circuit breaker-type GFCIs are more costly than receptacle-type GFCIs. A circuit breaker-type GFCI is less convenient than a receptacle-type because one has to go back to the main panel to reset the breaker, whereas the receptacle type is reset at the receptacle itself. The circuit breaker-type GFCI cannot be used in old wiring systems that use shared neutrals; a receptacle-type GFCI should be used.

8. INSTALL AN ARC FAULT CIRCUIT INTERRUPTER (AFCI).

An AFCI is a newly introduced circuit breaker (Fig. 9) that detects electrical arcing by monitoring the wave form of the voltage. Arcing generates high intensity heat, and expels burning particles that can easily ignite combustible materials. Arc faults occur when electrical products or wires are damaged, aged, or improperly used. An example is an extension cord that is repeatedly closed in a door, or a wire punctured by a nail or screw. Beginning 2001, the NEC will require that all bedrooms be protected with AFCIs.

ADVANTAGES: Provides additional protection against the risk of fire. Provides great protection in old house wiring where the condition of the wiring insulation is uncertain.

DISADVANTAGES: An AFCI is approximately eight times the cost of a standard breaker. It cannot be used in old wiring systems that use shared neutrals (see Section 4: Wiring and Receptacles).

FURTHER READING

“Panel Discussion: Assessing the Safety of Old-House Electric Panels,” Sam Roberts, *Old-House Journal*, January/February 1996.

“The Electric Panel,” Rex Cauldwell, *Journal of Light Construction*, October 1993.

PRODUCT INFORMATION

Cutler-Hammer, Pittsburgh PA; 800-525-2000; Advanced Power Center™ System; www.cutler-hammer.com.

Square D Company, 1415 South Roselle Road, Palatine, IL 60067; 847-397-2600; www.squared.com.

Siemens Energy & Automation, 3333 Old Milton Parkway, Alpharetta GA 30005; 770-751-2000; www.siemens.com/en/home.

GE Electrical Distribution and Control, 41 Woodford Avenue, Plainville, CT 06062; 860-747-7111; www.ge.com/indsys/components/serventrance.htm.

The Electrical Outlet, 800-227-5731 (obsolete breakers and other equipment).

Romac, 805-323-0896 (obsolete breakers and other equipment).

4

WIRING & RECEPTACLES

4.1

WIRING OVERVIEW

ESSENTIAL KNOWLEDGE

Wire provides the means by which electrical current is conveyed from the point of generation to the point of use. Wire types include transmission wires, service wires, branch circuit wiring, extension cords, and appliance power cords. This chapter focuses on the rehabilitation of residential branch circuit wiring.

Wire is sized according to the amperage it is designed to carry. Codes specify the maximum current-carrying capacity that is safe for different size wires. Wire diameter sizes are measured using the American Wire Gauge (AWG) system. In this system the bigger the number, the smaller the wire diameter. For example, No. 14 wire, which is commonly used for general service wiring in a house, is larger than No. 16. A problem in older houses is determining the size of existing wiring. Although the Code requires wire sizes be continually marked on the wire insulation, it is often illegible. If this is the case, a wire gauge or wire samples should be used to determine wire size.

Both sizes and composition of wiring systems have changed over the years. Knob-and-tube was the first widely used electrical system, prevalent from the 1890s to 1920. Knob-and-tube is a two-wire system in which nonconducting porcelain knobs hold wire 1" off the surface of studs and joists; porcelain tubes protect wire where it penetrates framing or crosses other wire. Electrical connections were not required to be made in an electrical enclosure. One wire was wrapped around the other and then the joint was soldered and taped. Wires that terminated in outlets and switches were protected with a tube of woven fabric called loom. This system contained no ground and the outlets were not polarized.

Less expensive than knob-and-tube, raceways made of wooden molding were used from about 1900 to the 1930s when they became illegal. In this system, wood moldings carried two or three wires in a grooved strip that was attached to the wall, and covered with a cap. This system had two major flaws: wood is quite combustible and homeowners mistaking the molding for picture molding would drive nails through it and the wires. If wooden molding raceways are encountered in rehab work they should be removed. Metal raceways, once considered to be moldings, were first recognized by the National Electrical Code in 1907, and are still used today.

The development of Greenfield—flexible-steel conduit for holding wires—in the late 1890s made it easier to snake conduit into walls and floors of houses. The flexibility was accomplished by wrapping galvanized steel strips into a tube (Fig. 1). The next development was armored cable or Type AC (also called by its tradename "BX") where wires were bound in a continuous spiral of galvanized metal. Although it was recognized by the NEC in 1899, Type AC use did not become widespread until 1920, and it did not achieve major popularity until the late-1920s. Early armored cable contained no ground; the armor itself was used as a ground. Safety was significantly improved in 1959 when the NEC required that all armored cable contain a slender aluminum bonding strip as a ground. Moisture plagued all these wiring products. In damp locations, rust would deteriorate the insulation and eventually lead to a ground fault. This problem was solved with the introduction of vinyl insulation after 1940.

Nonmetallic sheathed cable (Fig. 1) or Type NM was first recognized by the NEC in 1926. This cable consisted of two rubber insulated conductors sheathed in cloth. In 1928, the NEC required that ground conductors be installed in NM cable, however in some jurisdictions ungrounded NM continued to be used until the mid-1960s. After World War II the conductor insulation changed from rubber to plastic; the transition from cloth to plastic sheathing was completed in the early-'60s.

The most common problems found in residential electrical systems are loose or broken connections and deteriorated insulation. Usually loose or broken connections occur in electrical enclosures, and can easily be repaired. Knob-and-tube is the exception to this because wire splices occur inside walls. Deteriorated insulation, which is found in many older electrical systems, may not be as easily repaired. Deteriorating insulation has several causes, including the age and type of the insulation used, and its exposure to air, heat, or moisture. Rubber, the standard wiring insulation before 1930, has a life expectancy of about 25 years. Because rubber deteriorates rapidly in open air, most of this exposed wiring will be extremely brittle and potentially hazardous. In contrast, insulation on wiring in conduit or armored cable may only be cracking where it leaves the enclosure to make connections to switches or outlets. Exposure to the excessive heat from overloaded wires, or a wall or ceiling mounted light fixture, can cook wiring insulation, making it brittle. Wires that are overloaded will also stress the conductor, making it more likely to break. Old wiring insulation exposed to moisture should be replaced.

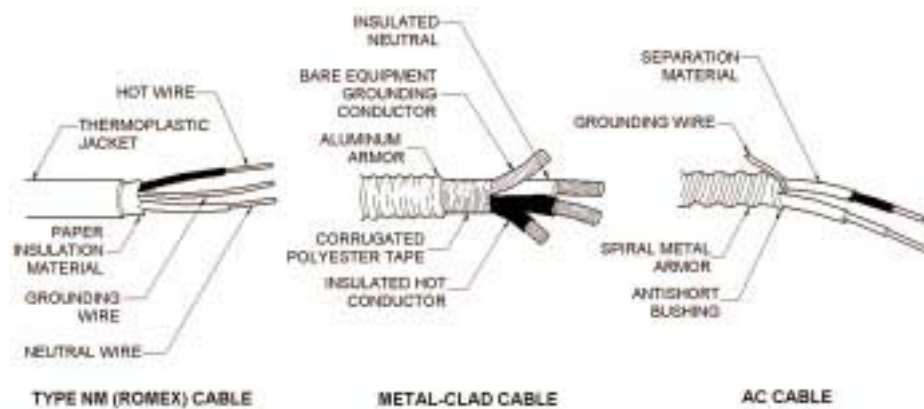

FIGURE 1

ELECTRICAL CABLE TYPES

TECHNIQUES, MATERIALS, TOOLS

1. REWIRE THE ELECTRICAL SYSTEM.

Rewiring a house or specific circuit is the safest way to solve existing wiring problems such as deteriorated insulation, stressed conductors, and overloaded circuits. However, it may not always be necessary. The trick to rewiring is to get wires to where they are needed while disturbing the walls and ceilings as little as possible. In general, to get wires from one location to another, a fish tape is used to pull wires through wall and ceiling cavities. For tips on rewiring, refer to “Rewiring Old Homes” on the *Journal of Light Construction* web page: www.jlconline.com/.

ADVANTAGES: Rewiring is the safest solution for wiring that is in poor condition.

DISADVANTAGES: Rewiring is labor intensive and can be very costly.

2. INSTALL WIRING RACEWAYS

Raceways provide a simple way to rewire or add a circuit (Fig. 2). In this system, base pieces are attached to walls or floors, wires are laid in the base, protective U-shaped wire clips are set over them at 12” intervals, and the covers are snapped on (Fig. 3). They are attached to either the service panel or an outlet with the use

of special adapters. Raceways are available in metal or PVC, the latter of which is available in white or wood laminate versions. Models are available that also encase both electrical and communication wires (Fig. 4).

ADVANTAGES: Significantly less costly than snaking wires through existing wall and ceiling cavities; accessible for future changes; locations of outlets and jacks can be easily changed. Outlets, jacks, and switches of some models are located inside the raceway channel, not in full-sized obtrusive boxes.

DISADVANTAGES: May not be acceptable aesthetically.

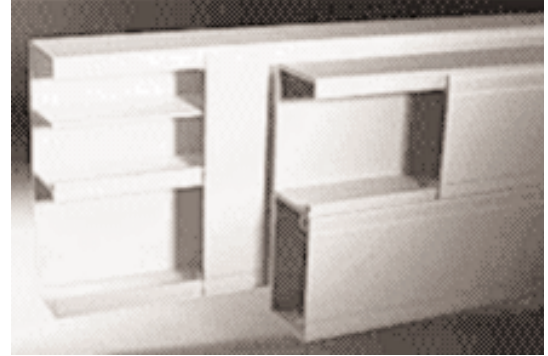
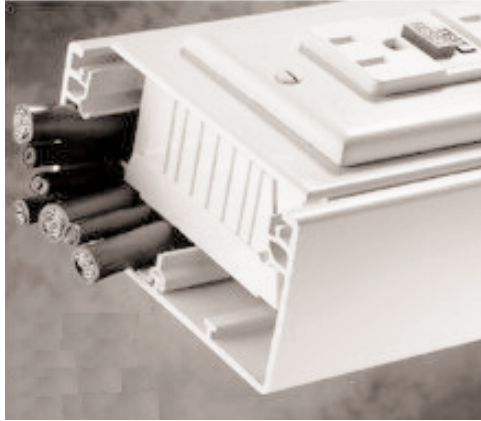

FIGURE 2, 3

PVC MULTI-CHANNEL RACEWAYS



FIGURE 4

ELECTRICAL & COMMUNICATION WIRING RACEWAY

3. REPAIR INSULATION.

Crumbling insulation may often be repaired with one of several techniques: insulating varnish can be applied over old rubber insulation; heat-shrink tubing can be installed; bare wires can be wrapped with electrical tape. Where there is enough slack in armored cable, cutting 12" off the armor to expose wire with good insulation is another solution. If there is not enough slack, the cable can be cut back 12", a junction box installed, and a new armored cable spliced in.

ADVANTAGES: Significantly less costly than rewiring; can add years to the life of the existing electrical system.

DISADVANTAGES: Solutions may not be acceptable to local code officials; a temporary fix. Installation of a new junction box may not be aesthetically acceptable.

FURTHER READING

“Working with Old Wiring,” David E. Shapiro, *Fine Homebuilding*, December/January 1999, pp. 112-115.

“Plug-In Electrical Testers,” Rex Cauldwell, *Journal of Light Construction*, December 1995.

“Rewiring Old Houses,” Sean Kenney, *Journal of Light Construction*, April 1999.

“Upgrading Kitchen Wiring,” Sean Kenny, *Journal of Light Construction*, May 1997.

PRODUCT INFORMATION

Carlton, 25701 Science Park Drive, Cleveland, OH 44122; 800-322-7566 (surface raceways moldings).

Wiremold Company, 60 Woodlawn Street, West Hartford, CT 06110; 800-621-0049; www.wiremold.com (surface raceways moldings).

4.2

ALUMINUM WIRING

ESSENTIAL KNOWLEDGE

When the price of copper soared in the early 1960s, manufacturers responded by making residential electrical wires out of aluminum. Between 1962 and 1972, nearly 2 million homes were wired with aluminum, and many of these have not been upgraded. The hazard with aluminum wiring arises from two types of corrosion: 1) the connection of dissimilar metals, and 2) the oxidation of exposed aluminum. Both increase the electrical resistance of the wiring, making it hotter when in use and therefore a fire hazard. Also, because aluminum expands and contracts significantly more from changing temperatures than copper, unless all connections are made very tightly, the wiring may pull loose as a result of the heat of resistance.

Aluminum wiring can be identified by the dull gray color of the wire or by “AL” on the sheathing. Receptacles and outlets used with aluminum wiring must be marked “OC/ALR,” which are designed to prevent contact between dissimilar materials. Warning signs of problems include: warm cover plates, devices that fail to work for no apparent reason, and strange odors or smoke.

TECHNIQUES, MATERIALS, TOOLS

There are three basic ways of correcting aluminum wiring:

1. REPLACE EXISTING WIRING.

The safest way to eliminate the fire hazard potential of aluminum wiring is to remove all of the aluminum wire and install new copper wire. It may be possible to use the existing wire as a guide to bring a new cable through the wall. If not, the wire will have to be snaked. This will be difficult if all wiring is enclosed in finished walls and ceilings.

ADVANTAGES: This fix eliminates the fire hazard potential of aluminum wiring connections in its entirety.

DISADVANTAGES: Rewiring an entire house is costly.

2. SPLICE WIRE USING AMP COPALUM CONNECTORS.

A more practical method for reducing the fire hazard potential of aluminum wiring connections is by splicing or “pigtailling” a short length of copper wire to each aluminum wire using an AMP COPALUM connector and heat shrink tubing system. It is applied using special tooling and is only available with installation

by specially-trained electricians. This system is the only method considered by the US Consumer Product Safety Commission (CPSC) to be a permanent repair. Its recommendation is based upon extensive testing. **ADVANTAGES:** Avoids the expense of rewiring entire house and therefore is less costly. **DISADVANTAGES:** System is not available in all parts of the country; installation requires specially-trained electrician and specialty tools.

3. SPLICE WIRE USING “SCOTCHLOK” TWIST-ON CONNECTORS.

Pigtailing with certain types of connectors, although they might be presently listed by UL for the application, can lead to increasing the fire hazard of the connection. Following special installation procedures, the 3M “Scotchlok” connectors are considered by CPSC to be the best available alternative to the COPALUM crimp. 3M Scotchlok has several features that make it safer than other connectors: a non-flammable shell, a metal shell around the spring, and a heavier spring wire. In this system, the bare aluminum wire is abraded under a coating of non-flammable oxide inhibitor. The connector spring is then filled with oxide inhibitor before the connector is applied to the pre-twisted wires. This work must be done by a qualified electrician.

ADVANTAGES: Avoids the expense of rewiring entire house; Specialty tools are not required; availability is not limited to certain parts of the country.

DISADVANTAGES: This system is only as good as the installation technique; installation requires a qualified electrician.

FURTHER READING

The Aluminum Wire Information Website, www.mhv.net/~dfriedman/aluminum.htm.

“Aluminum Wiring in Residential Properties: Hazards & Remedies, www.inspect-ny.com/aluminum.htm.

PRODUCT INFORMATION

AMP Inc., P.O. Box 3608, Harrisburg, PA 17105; 717-986-7777; 800-522-6752; www.amp.com

3M, 6801 River Place Blvd, Austin, TX 78726; 512-984-1800; 800-245-3573; www.mmm.com/elpd/index/.

4.3

RECEPTACLES

ESSENTIAL KNOWLEDGE

Receptacles (also known as outlets) supply power to portable equipment used in houses, such as floor lamps, radios, and toasters. Up until the mid-1960s, ungrounded receptacles were installed in most houses (Fig. 5). In older homes, these two-prong receptacles were not polarized. Grounding and polarization are important features of an electrical system. Equipment grounding reduces the shock hazard from electrical boxes or equipment that may become “hot” because of a conductor insulation failure or loose connection. In this system each metallic, noncurrent-carrying part of the electrical system (electrical boxes, equipment frames, appliances, motors, and conduit) is connected to the ground wires of each branch circuit; to the neutral bar of the load center; and then to the earth. If a hot wire accidentally touches the metal housing of an electric drill, the fault current will flow back to the service panel via the equipment grounding conductor, and the circuit breaker will trip. If this system was not in place, a person could receive a serious shock from a faulty appliance if he or she were not insulated from the ground. Grounded receptacles are also required for the proper functioning of plug-in surge protectors used to protect sensitive electronic equipment. Surge protectors work by directing excess voltages and currents into the grounding system. Therefore, without a high quality ground in place, the surge protector is useless.

In an electrical circuit, keeping the hot and neutral separate is called polarization. It is achieved by making the neutral blade of a plug and the neutral slot of a receptacle wider than their hot counterparts. This ensures that the hot and neutral wires of an ungrounded appliance cannot be reversed. If polarity is accidentally reversed, the exposed socket of a properly wired lamp could deliver a shock even when the switch is off. Reversed polarization does not occur in grounded appliances because the grounding pin forces proper polarization.

In most cases, non-operable receptacles can easily and inexpensively be repaired. Loose wire connections can be tightened and failed receptacles can be replaced. The NEC requires that all new receptacles, whether for replacements or new installations, be grounded. This does not mean that existing two-prong receptacles in a house need to be replaced, although this would improve the safety of the existing electrical system and therefore should be considered.

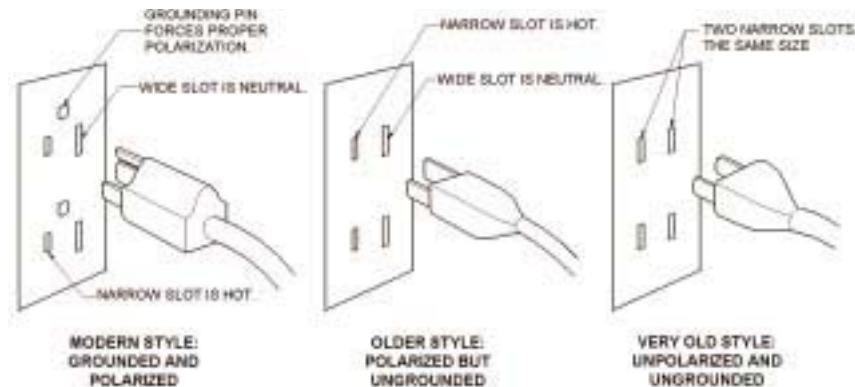

FIGURE 5

RECEPTACLES

TECHNIQUES, MATERIALS, TOOLS

There are several methods for converting a two-prong outlet into a three-prong, grounded receptacle:

1. REPLACE EXISTING WIRING.

Running new electric wiring with a ground from the service panel to the outlet is the most certain way of providing an uninterrupted ground where the existing wiring system has none (early nonmetallic sheathed cable) or where the continuity of the ground is questionable (early armored cable with no bonding strip). That certainty may be desired on circuits where plug-in surge protectors are used to protect expensive electronic equipment. For rewiring options, refer to sections above. This method is only as good as the grounding of the service panel.

ADVANTAGES: A safe, reliable way to provide a grounded receptacle.

DISADVANTAGES: Relatively costly. Existing wiring may be in good condition and not worth the cost of removing it to install a new grounded cable.

2. INSTALL A NEW GROUND CONDUCTOR.

Where an uninterrupted ground does not exist, installing a new, adequately protected ground conductor to a reliable ground is the next best thing to installing a new cable. To provide adequate protection, the ground conductor will most likely have to be fished through walls. It cannot be tucked under baseboards or tacked in the same fashion as telephone wires. The ground can be run either back to the service panel, or to the nearest accessible point of the grounding electrode system. This method is only as good as the grounding electrode system.

ADVANTAGES: Less costly than installing a new electrical cable. If the grounding electrode system is accessible, the ground conductor will not have to run back to the service panel.

DISADVANTAGES: Ground conductor may have to be run back to the service panel because it is less likely to be disturbed there than if it is connected to another part of the grounding electrode system.

3. CONNECT RECEPTACLE TO THE GROUNDED RECEPTACLE BOX.

Where the existing receptacle box is grounded, a grounded receptacle can easily be installed by connecting a wire jumper from the receptacle's grounding terminal to the back of the box. The absence of a copper grounding conductor does not mean that the box is not grounded. Where armored cable is used, it does not have a separate ground wire because the steel jacket acts as the ground conductor. The addition of a bonding strip in the armored cable, a 1959 NEC requirement, greatly improved this system's continuity to ground. However, it cannot be assumed that the presence of armored cable means that the receptacle box is adequately grounded. Both the box and armor need to be tested with a circuit tester or another electrical device for continuity to ground.

ADVANTAGES: Easily and inexpensively accomplished.

DISADVANTAGES: Potential for the armor to rust and create a discontinuity, which would result in the false impression of the outlet being grounded when it is not.

4. INSTALL A RECEPTACLE-TYPE GROUND FAULT CIRCUIT INTERRUPTER.

The NEC forbids replacing a two-prong outlet with an ungrounded three-prong outlet unless it is a GFCI type. The reason is that although the GFCI is not grounded itself, it protects users by shutting off the current in the event of a ground fault. It also protects receptacles downstream. Therefore the code allows all downstream receptacles to be replaced with non-GFCI three prong receptacles if they are labeled with a sticker stating "GFCI Protected". A new GFCI outlet produced by Leviton, called the Smart Lock GFCI, contains two new safety features: 1) the reset button is mechanically prevented from being reset if the GFCI is damaged after a voltage surge, and 2) a diagnostic feature prevents downstream receptacles from operating if the GFCI outlet is wired incorrectly.

ADVANTAGES: Easy installation; inexpensive.

DISADVANTAGES: A surge protector plugged into this type of circuit is rendered useless. A ground is needed to make the surge suppressors or line filters, which are commonly used to protect computer systems, effective.

FURTHER READING

"Installing Electrical Boxes and Receptacles," Rex Cauldwell, *Fine Homebuilding*, June/July, 1996.

"Converting 2-prong to grounded 3-prong receptacles," Redwood Kardon, www.codecheck.com/frame.htm

"Don't Guess at GFCI Regs!," J. Michael Rhodes, *Electrical Contractor Magazine*, May 1996.

"More 'Groundless' Worries," David E. Shapiro, *Electrical Contractor Magazine*, April 1999.

PRODUCT INFORMATION

Pass & Seymour/Legrand, P.O. Box 4822 Syracuse, NY 13221-4822; 315-468-8430 (phone), 315-468-8388 (fax); www.passandseymour.com/ (self-contained devices).

Leviton Manufacturing Co, 59-25 Little Neck Parkway, Little Neck, NY 11362; 800-229-4040; www.leviton.com/.

Eagle Electric Manufacturing Co., Inc., 45-31 Court Square, Long Island City, NY 11101; 800-366-6789; www.eagle-electric.com.

5

LIGHTING & CONTROLS

5.1

INTERIOR LIGHTING

ESSENTIAL KNOWLEDGE

Lighting provides illumination for safety, security, and the performance of visual tasks. Electric lighting systems are comprised of two parts: the lamp or bulb and the light fixture. About 95% of the lamps used in older residential homes are incandescent, the rest are fluorescent.

In general, an incandescent lamp works by passing electrical current through a filament which heats up to the point where it produces light. The use of electric lighting became affordable and practical when Thomas Edison invented the incandescent light bulb in 1879. The nature of these early lamps became a critical influence on the design of the fixtures.

For nearly 100 years, prior to Edison's invention, gas was the primary lighting system in the U.S. With the advent of the incandescent light bulb, gas began to lose its hold on the market. From the early 1880s until about 1910, electricity was not the most reliable energy source. As a result, early electric light fixtures were a combination of gas and electric: gas fixtures upgraded with one or two electric arms. Combination fixtures remained in catalogues as late as 1912, but were sharing their pages with all-electric fixtures by this time. After 1913 gas lost its dominance to electricity.

Early electrical fixtures did not have shades because the modest light output was best left unobscured (Fig. 1). As the quality improved a new breed of all-electric lighting emerged free of accoutrements of earlier gas light fixtures. Three general illumination systems emerged: direct illumination, indirect illumination, and semi-direct illumination.



FIGURE 1

PAN LIGHT (1910-1930)

Although Edison patented a fluorescent lamp in 1896, the first commercial production of fluorescents was not until 1938. In general, a fluorescent lamp works by sending an electric arc down a phosphorous-lined glass tube, energizing the phosphors causing them to emit light. This is accomplished with the help of two additional devices: a ballast and a starter. The ballast limits the current flowing through the lamp to a predetermined value, and the starter performs the preheat function used to light the fluorescent lamp. This preheat circuit is seldom used today, having been replaced by instant-start and rapid-start circuits. The major advantages of fluorescent over incandescent is that they produce two to four times as much light, and can last up to 20 times longer. Long tube fluorescents also have lower surface brightness, producing less reflected glare and shadow. Many improvements have been made to fluorescents since they were first introduced. Today the color rendition of fluorescents can be almost the same as incandescents, and many are dimmable.

The electrical parts of a light fixture have a finite life. As mentioned in Section 4, incandescent lights can heat up fixture wires, causing insulation to deteriorate. This can also happen to wires near a fluorescent's deteriorating ballast if it is not thermally protected. Poor contact between the bulb and the fixture is another problem: over time and through repeated lamp replacement, contacts can corrode or lose their resilience and cause the fixtures to function poorly or not at all. Fluorescent light fixtures can have malfunctioning starters and ballasts.

Beyond the functioning of fixtures, a broader issue may exist. Existing fixtures may not provide sufficient light for contemporary tastes and needs. Lamps with higher lumen-output are not necessarily the best solution. The fixture may not be designed to handle the additional power and the heat generated by a higher output lamp. A lamp that is too large, too bright, or too frosted will compromise the effect of a period light fixture. For instance, pan lights (flush mounted ceiling fixtures with bare bulbs) were popular in bedrooms and less formal living rooms from about 1910 to 1930 and were designed for small round globe lights in the 15- to 40-watt range. Installing a larger lamp may actually have a negative effect by creating glare.

TECHNIQUES, MATERIALS, TOOLS

1. REWIRE EXISTING FIXTURE.

If the existing fixture in a home has historical value or is otherwise unique, rewiring may be an option. As the fixture is disassembled, document how all of the parts go together. Replace a failed lamp socket by prying off the shell with a screwdriver. When the new socket is connected make sure the wire wraps clockwise around the terminals and that there is a cardboard insulator between the socket and the shell. When removing old wiring with cracked or dry insulation, first lubricate the fixture insides with silicone spray; don't force the wiring. Use 18- or 20-gauge lamp cord for replacement.

ADVANTAGES: Repairing an original fixture has more historic value than installing a new fixture, and a matching reproduction may not be available.

DISADVANTAGES: Requires more labor than replacing fixture and therefore, depending upon the price of a new fixture, may be more costly.

2. INSTALL A NEW, PERIOD REPRODUCTION FIXTURE.

Many lighting manufacturers now offer reproductions of historic light fixtures. One resource that lists some of these companies is *Old-House Journal's Restoration Directory*.

ADVANTAGES: Requires less labor than repairing existing fixture and therefore, depending upon the fixture price, may be less costly.

DISADVANTAGES: Replacing the fixture may be costly; historic value of fixture is compromised.

3. INSTALL ADDITIONAL LIGHT FIXTURES.

Where the existing light fixture does not provide adequate lighting, the number and variety of light sources may be increased. In addition to the conventional incandescent and fluorescent light fixtures, other lighting systems may be considered:

Low voltage lighting fixtures utilize halogen lamps, which provide a more precise focus of the light, bet-

ter light quality, and lower operating costs than traditional incandescent lighting. Halogen lamps are 50% brighter per watt than typical light bulbs and last twice as long. The smaller size of some of these fixtures makes them useful in places where larger incandescent fixtures will not fit, such as under counters. A transformer is required to convert the current from 120 volts AC to 12 volts DC. The transformer should be out of view but easily accessible.

Dedicated compact fluorescent light fixtures provide three to four times more light output per watt than traditional incandescent lighting. Although fixtures can be considerably more costly than a comparable incandescent, utility companies often provide rebates offsetting this added cost.

White LED (light emitting diode) lighting consumes less than a quarter of the electricity that fluorescent lighting does, and lasts about ten times longer. A 1.2 watt white LED cluster is as bright as a 20-watt incandescent lamp. Light quality is comparable to that of cool white compact fluorescent lights (CFLs). Currently considered expensive, look for their costs to come down as they become more popular and more manufacturers begin to make them. LEDs are available for direct replacement of incandescent lamps, as strip lights for installation under cabinets, and in custom arrays for custom-built down lights, sconces, and surface mounted fixtures.

ADVANTAGES: In historical applications, wall sconces and brackets will add to the light level without detracting from historic ceiling fixture. Additional light fixtures can increase the quality of light within a room and reduce glare.

DISADVANTAGES: Certain fixtures can be expensive.

4. INSTALL A DIMMER SWITCH.

To reduce a light fixture's glare, replace the existing light switch with a dimmer switch. A dimmer switch allows one to simulate the low light levels of a historic light fixture or run them at full output as required for contemporary needs. Dimming a light fixture saves electricity and extends the life of incandescent bulbs.

ADVANTAGES: Relatively easy to install, and reasonable cost.

DISADVANTAGES: Dimmers reduce the efficiency of incandescent lamps. They can produce an audible buzzing sound, and put radio frequency interference (RFI) into a branch circuit.

FURTHER READING

"White LED Lighting," Partnership for Advancing Technology in Housing, Technology Inventory, www.nah-brc.org/homebase/xtechinv.html.

#1 Lighting, Home Energy Brief, Rocky Mountain Institute, 1994.

"Dedicated Fixtures for Compact Fluorescents," Tim Maker, *Journal of Light Construction*, January 1994.

"Lighting Your Life, a Home Lighting Guide," American Lighting Association, 1992; www.americanlightingassoc.com/life.htm.

"Low Voltage Lighting," Jeff Ridenour, *Journal of Light Construction*, May 1996.

American Lighting 1840-1940, Nadja Maril, Schiffer Publisher, 1995.

PRODUCT INFORMATION

Old-House Journal's Restoration Directory, Hanley-Wood, Inc., One Thomas Circle, NW, Suite 600, Washington, DC 20005; 202-737-3409.

Midwest Lamp Parts Company, 3534 North Spaulding Avenue, Chicago, IL 60618; 377-539-0628 (replacement parts for old fixtures).

B&P Lamp Supply, Inc., McMinnville, TN 37110; 615-473-3016 (replacement parts for old fixtures).

W.N. de Sherbinin Products, Inc., POB 63 Hawleyville, CT 06440; 203-791-0494 (replacement parts for old fixtures).

Kim Lighting, 16555 E. Gale Ave., P.O. Box 1275, City of Industry, CA 91749; 818-968-5666.

The Lighting Resource, P.O. Box 48345, Minneapolis, MN 55448-0343; 612-939-1717.

Holly Solar Products, P.O. Box 864, 1340 Industrial Ave., Petaluma, CA 94952; 800-622-8716.

Automated Voice Systems, Inc., 17059 El Cajon Avenue, Yorba Linda, CA 92686, 714-524-4488; www.mas-tervoice.com.

LEDtronics, 4009 Pacific Coast Highway, Torrance CA 90505; 310-534-1505.

5.2

EXTERIOR LIGHTING

ESSENTIAL KNOWLEDGE

In its most practical sense, exterior lighting provides illumination for safety and security. It can illuminate a safe path to the entrance of a house, or the grounds around the house so that any prowlers are visible. Some of the same problems encountered in interior light fixtures are encountered outside (see section above). Additionally, because of their exposure to sunlight and moisture, exterior light fixtures are susceptible to corrosion.

Exterior light levels at an existing home are often insufficient. Walking on an unlit path can be difficult or even hazardous, especially at changes of grade. Too much light can create blinding glare, which can also make it easier for a burglar to remain in the shadows unseen, defeating the purpose of security lighting. In general, lower levels of light are preferable for both security and safety. Exterior lighting should also provide a gentle transition from darkness outside to brightness inside, and vice versa, which is better for older people who may have poor night vision and poor depth perception.

There are special requirements for running standard 120 volt wiring to a new exterior light fixture, such as a lamp post. Conduit is required to protect all wiring above ground, and is often necessary underground. It can be made of polyvinyl chloride (PVC), thin-wall metal, or heavy-wall (rigid) conduit. PVC and thin-wall metal conduit are easy to work with, but must be buried at least 12" underground. Rigid metal conduit is more costly and harder to work with, but it only needs to be buried 6" underground. If local codes permit, a heavily sheathed non-metallic cable called UF cable can be used instead of conduit. It also needs to be buried at least 12" underground.

All exterior lamps and light fixtures should be rated for outdoor use. Lamps should have a corrosion resistant nickel or copper-coated base and hardened glass bulb. Fixtures should be made of corrosion-resistant materials such as copper, brass, or aluminum and have watertight housings. Plastic fixtures can also be used but they may degrade from exposure to heat and sunlight. Fluorescent and high intensity discharge (HID) lamps require additional current transformers called ballasts, which are integral parts of the fixture and should also be rated for outdoor use.

TECHNIQUES, MATERIALS, TOOLS

1. REWIRE EXISTING FIXTURE.

Refer to Section 5.1 above, TECHNIQUES, MATERIALS, TOOLS, entry 1.

2. INSTALL NEW, PERIOD REPRODUCTION FIXTURE.

Refer to Section 5.1 above, TECHNIQUES, MATERIALS, TOOLS, entry 2.

3. INSTALL A LOW-VOLTAGE LIGHTING SYSTEM.

Where additional lighting is required, low voltage lighting may be adequate. Low voltage lighting fixtures are powered by a transformer that lowers the voltage and converts the current from 120 volts AC to 12 volts DC. Lowering the voltage eliminates the risk of electrical shock, and therefore this system's wiring does not have to be buried or protected by a conduit. These systems are readily available in kits.

ADVANTAGES: Easier and less costly to install than standard voltage fixtures; easily relocated.

DISADVANTAGES: These systems are limited to runs of about 100', after which the voltage drop will start to affect the light intensity.

4. INSTALL PHOTOVOLTAIC (PV) LIGHTING.

Where new lighting needs to be added, a photovoltaic lighting system can be installed. In this system, photovoltaic solar panels convert sunlight to electricity that is stored in compact, highly efficient batteries for use at night (Fig. 2). These systems can be used for decorative lighting, path lighting, patio, and security lighting. They are available as self-contained units or as lights grouped together with a wire. The self-contained units must be installed in a sunny location. The wiring for the latter system is low voltage, and therefore does not have to be protected by conduit or direct burial.

ADVANTAGES: PV systems are easy to install and can be inexpensive. No additional power from the service panel is required because PV systems are self-contained.

DISADVANTAGES: The number of hours per night that the lighting will operate is dependent upon the amount of sunlight the system receives, which is a function of geographical location, weather conditions, nearby objects, and time of year.



FIGURE 2, 3

PHOTO VOLTAIC FLOOD LIGHT

LED BULBS

5. INSTALL A FULL CUT-OFF FIXTURE.

This type of fixture directs light rays below the horizon of the fixture; down and out instead of up and sideways. This results in a fixture with less glare and more light on the walking surface.

ADVANTAGES: Full cut-off fixtures reduce light trespass (light shining into a neighboring property); save energy by focusing light only where it is intended; reduce glare and light pollution.

DISADVANTAGES: Higher initial cost.

6. INSTALL WHITE LED LIGHTING.

If an exterior fixture needs to be replaced, consider LED lighting (Fig. 3). Currently, manufacturers consider applications such as gardens, walkways, and decorative fixtures outside garage doors to be the most cost-efficient use of LEDs. For a further description refer to Section 5.1 above, **TECHNIQUES, MATERIALS, TOOLS**, entry 3.

ADVANTAGES: Consumes less than a quarter of the electricity used by fluorescent lighting and lasts about ten times longer.

DISADVANTAGES: Because white LED lighting is relatively new to the market place, few manufacturers offer it; can be costly.

FURTHER READING

“A Guide to Exterior Lighting,” Martha Tuzson Stockton, *Fine Homebuilding*, February/March 1998.

“Full Cut-Off Outdoor Light Fixtures,” Partnership for Advancing Technology in Housing, Technology Inventory, www.nahbrc.org/homebase/index.html.

“Outdoor Photovoltaic Lighting,” Energy Efficiency and Renewable Energy Network (EREN), U.S. Department of Energy, www.eren.doe.gov/consumerinfo/refbriefs/db8.html.

PRODUCT INFORMATION

Old-House Journal's Restoration Directory, Hanley-Wood, Inc., One Thomas Circle, NW, Suite 600, Washington, DC 20005, 202-737-3409.

LIGHTING-INC.COM, 1236 Wood Station Place, St. Louis, Missouri 63021; 314-225-7042; www.lighting-inc.com/searchman.html.

Nightscaping, 1705 E. Colton Ave., Redlands, CA 92374; 800-544-4840; www.nightscaping.com.

Solar Outdoor Lighting, Jade Mountain Inc., P.O. Box 4616, Boulder, CO 80306; 800-442-1972; www.jademountain.com/outdr.html.

5.3

CONTROLS

ESSENTIAL KNOWLEDGE

Switches control the power used in an electrical circuit. A standard switch has two settings, on and off. When on, electricity flows through the circuit from its source to a point of use. When off, the circuit is opened, interrupting the flow of electricity. Most light fixtures and many receptacles are controlled by at least one switch. A dimmer has more than two settings. It is able to control the level of light from very dim to bright by controlling the voltage of the electrical current reaching a light fixture.

A key-type switch built into the fixture operated early wall, ceiling, and table fixtures. In 1890, the push-button switch was introduced and remained the most popular switch used for the next 40 to 50 years. In order to minimize arcing, it was designed with springs that would “snap” the blades away from the contacts quickly. This resulted in the switches’ distinctive snapping sound. For a quiet switch, mercury switches were developed, with contacts made and broken at the boundary of a small pool of mercury. There were no springs to fatigue or metal contact surfaces to fail. Mercury switches are still made but are difficult to find. “Tumble” switches were available around 1898, but did not become popular until after alternating current became the standard.

Wall switches are one of the most reliable devices in the house. A good quality switch, under normal use, will last 20 years or more, but at some point its springs break or its contacts pit. The slight mechanical movement caused by flipping the switch on and off can also loosen wiring connections. Because replacing a switch is easy and inexpensive, the homeowner may want to replace the switch long before it fails.

There are a few problems associated with dimmers: they reduce the efficiency of incandescent

lamps, they often produce an audible buzz, and they may put radio frequency interference (RFI) into a branch circuit. Any load on this branch circuit such as an AM radio, TV, or cordless telephone will receive this RFI noise. This is not a problem where lighting and receptacle circuits are separate. Standard dimmers should not be used to control fans or any motorized device.

TECHNIQUES, MATERIALS, TOOLS

1. INSTALL A NEW, PERIOD REPRODUCTION SWITCH.

With the restoration boom of the late 1970s a new interest was generated in the push-button switch. In 1985, Peter Brevoort of Michigan began manufacturing new push button switches that he and an electrical engineer had redesigned to meet current codes. It retained the outward appearance, and the mandatory snap of the originals. Push-button switches are available from a number of companies that specialize in historic reproductions.

ADVANTAGES: Preserves the historical accuracy of the home.

DISADVANTAGES: More costly than a standard switch.

2. INSTALL A DIMMER WITH A BUILT-IN NOISE FILTER.

To eliminate radio frequency interference associated with the use of dimmers, install a dimmer with a built-in noise filter.

ADVANTAGES: A separate device is not needed to control RFI, and therefore another junction box is not required.

DISADVANTAGES: More costly than a standard dimmer switch.

3. INSTALL A LAMP DEBUZZING COIL (LDC).

To eliminate dimmer-produced radio frequency interference, a LDC can be installed at the dimmer. LDCs fit into a 4" x 4" junction box that for best results should be located as closely as possible to the dimmer.

ADVANTAGES: Most effective way to reduce RFI.

DISADVANTAGES: LDCs have their own audible buzz. Another junction box may not be aesthetically acceptable.

4. INSTALL A SELF-CONTAINED DEVICE (SCD) TYPE SWITCH.

Where a new switch is required, a SCD can be installed. SCDs are a time-saving method used to install receptacles and switches (Fig. 4). They were first developed for the manufactured home and recreational vehicle industry, but are also appropriate for site-built houses. In this system, the switch makes a direct attachment to the electrical cable and then, with use of a special tool, is inserted into the wall. The cable is not cut, and an electrical box is not installed. SCDs are not appropriate for direct replacement of conventional light switches.



FIGURE 4

SELF-CONTAINED DEVICE TYPE SWITCH

ADVANTAGES: Can be installed in a quarter of the time it takes to install conventional switches.

DISADVANTAGES: SCDs can only be used with grounded nonmetallic sheathed cable; this limits their use to houses wired within the last 20 years.

5. INSTALL WIRELESS SWITCHES.

Where a switch needs to be added or relocated, wireless switching can be installed. Wireless control systems utilize infrared light or radio frequency signals to communicate with controls for lighting and electrical devices. A wireless three-way switching kit contains a battery-powered wireless wall switch, and a receiver switch that replaces an existing switch. The wireless switch sends a signal to the receiver switch, allowing a fixture to be controlled from either location. Another system can control lamps or appliances plugged into a receptacle through the use of a receptacle switch module.

ADVANTAGES: Substantial cost savings are realized because rewiring is not required to add a new light switch. This system does not use existing house wiring as a means of communicating, and therefore is not susceptible to other household product cross talk, which can create erratic behavior.

DISADVANTAGES: Can cause interference.

6. INSTALL A FIBER OPTIC SWITCH.

Installing a fiber optic switch can eliminate the danger of operating a wall switch from a wet location such as a bath or shower. In this system a light pulse is emitted from the switching module, travels along a fiber optic cable to an optical membrane wall switch, and is reflected back. Pressing the wall switch breaks the light pulse, activating the switching module.

ADVANTAGES: Fiber optic switches will not corrode and fail due to moisture. Eliminates the risk of electrical shock when operating a switch from a damp or wet location.

DISADVANTAGES: The distance between the switch and electrical device is limited to runs of about 100', based on the ability of the fiber-optic cable to conduct light.



FIGURE 5

MOTION-SENSOR SWITCH

7. INSTALL A MOTION-SENSOR SWITCH.

Motion sensor switches utilize an infrared sensor to detect moving heat sources to activate the switch (Fig. 5). They can be adjusted to stay on from a few seconds to 20 minutes, and will remain on as long as there is movement in the room. Some motion-sensor switches also contain a photocell sensor that will prevent the switch from turning the lights on when there is enough light already in a space. Some models can be switched from automatic to manual operation at the flip of a switch.

ADVANTAGES: Saves energy by turning lights on only when they are needed.

DISADVANTAGES: More expensive than conventional light switches. Less sensitive sensors can shut off the lights while a room is still occupied and little movement is taking place.

FURTHER READING

Home Automation Systems, The Energy Efficiency and Renewable Energy Network (EREN)/ U.S. Department of Energy; www.eren.doe.gov/consumerinfo/refbriefs/ad7.html.

“Sell Energy Technology to Reduce Long Term Costs,” Paul Rosenberg, *Electrical Contractor Magazine*, May 1995.

PRODUCT INFORMATION

Classic Accents, P.O. Box 1181, Dept. OHJ, Southgate, MI 48195; 313-282-5525 (push-button switches).

Lutron Electronics Co., Inc., 7200 Suter Rd., Coopersburg, PA 18036; 800-523-9466; www.lutron.com.

Fiberswitch Technologies, 2511 N. Plaza Drive, Rapid City, SD, 57702; 800-811-9370; www.rapidnet.com/~fiberswitch.

Sensorswitch, Inc., 900 Northrop Rd., Wallingford, CT 06492; 203-265-2842.

Leviton Manufacturing Co, 59-25 Little Neck Parkway, Little Neck, NY 11362; 800-229-4040; www.leviton.com.

Eagle Electric Manufacturing Co., Inc., 45-31 Court Square, Long Island City, NY 11101; 800-366-6789; www.eagle-electric.com.

6

ELECTRIC BASE-BOARD HEATING

ESSENTIAL KNOWLEDGE

Electric baseboard heating has often been used in houses where installed cost was the primary concern. It may be economical to use where little space heating is needed, such as in a cooling-dominated climate or in a superinsulated house with a small heating load, or in regions with low electric rates. Its advantages include low-cost installation, no indoor combustion, and fast response time to thermostat settings. Since each room has an independent system with its own wiring and thermostat, zoning is flexible. Good quality units are quiet (except for minor noise of expanding and contracting metal components), and usually the only maintenance is occasional dusting. Some occupants may choose electric heat to eliminate the possibility of indoor gas leaks.

If electric baseboard heating is used for such reasons as scarce fuel supplies or allergies, there are other electrical resistance systems: (a) Electric thermal storage systems take advantage of lower off-peak electric rates. The storage unit recharges from 11PM to 7AM and provides heat when needed, with potentially significant energy savings. The units are more costly than electric baseboards; (b) electric radiant floors or ceilings include electric wiring embedded in integrated panels, flexible mats, or finish materials. Panelectric and Suncomfort make gypsum boards with embedded wiring for radiant ceilings. Electric radiant boasts immediate response time, but some complain of hot heads from radiant ceilings, and radiant floor installation can be expensive; (c) modular electric radiant panels are usually installed on walls or ceilings, but sometimes in a floor or kickspace. Attractive and convenient, they are more costly than baseboards without saving energy; (d) electric hydronic baseboard heaters (Fig. 1) contain immersion heating elements in an antifreeze solution. Used chiefly in commercial applications, their thermal mass creates an energy-saving lag effect at shutdown but units are more costly; (e) electric space heaters are usually supplemented by a fan. They move air quickly but are thicker and a bit more expensive; (f) electric furnaces contain elements to heat air forced through ducts. The distribution can accommodate air conditioning but the system cannot be zoned as conveniently as electric baseboards. The heating elements are activated individually and sequentially, potentially saving energy during mild weather when full power is not needed; and (g) electric boilers use heating elements to effect a hydronic distribution system. May be more comfortable than electric furnaces due to the radiating nature of some hydronic systems compared to the “drying-out” effect of forced air. These systems don’t accommodate air conditioning and energy costs will be similar to electric forced air.

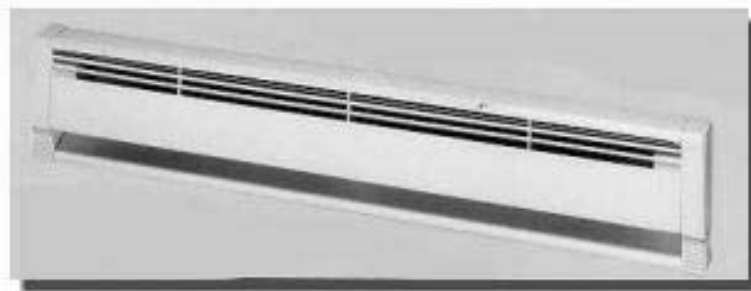

FIGURE 1

ELECTRIC HYDRONIC BASEBOARD HEATER

TECHNIQUES, MATERIALS, TOOLS

1. MAINTAIN EXISTING SYSTEM.

Electric resistance systems should be inspected periodically to ensure that components are operating properly and no connections are loose or burned. The fuses or circuit breakers in some electric systems can easily be checked. Units should be cleaned periodically with a brush or vacuum. There should be adequate clearance from combustibles. Mechanically damaged baseboard heaters should be repaired or replaced.

ADVANTAGES: Quiet. Lowest first cost, lowest maintenance. No combustion gases or depressurization.

DISADVANTAGES: High energy costs of electric resistance heating in many regions. There has been some concern regarding the health effects of electromagnetic fields (EMFs), which electric resistance heating systems generate during operation. Systems with large open loops create a stronger field than systems that route current back along the same route.

2. REPLACE OLD BASEBOARD UNITS WITH NEW UNITS.

Baseboard heating units are usually installed under windows to heat infiltrating cool air. The unit should sit at least 3/4" above the finished floor or carpet to allow cooler air on the floor to reach the radiator fins (Fig. 2) so it can be heated. The heater should also be installed tightly to the wall to prevent warm air from convecting behind it and streaking the wall with dust particles. The quality of baseboard heaters varies. Cheaper models can be noisy when expanding and contracting, and have poor temperature control. New models are not significantly improved from older models, but may be more compact. Units should carry Underwriter's Laboratories (UL) and the National Electrical Manufacturer's Association (NEMA) labels. Units 2' to 12' long rate from about 100 to 400W/ft. Electric hydronic baseboards are rated from 300 to 2,000 W.

ADVANTAGES: Opportunity to improve the quality or change the size of baseboards.

DISADVANTAGES: Will not significantly decrease energy costs.

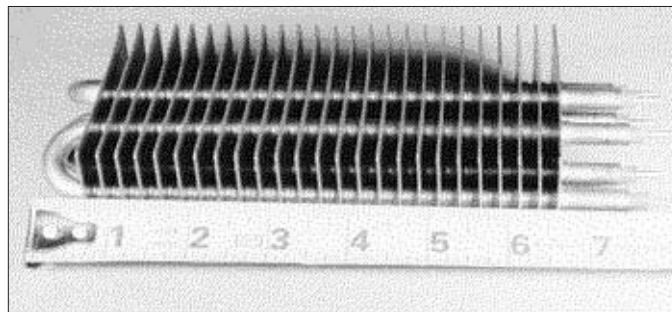

FIGURE 2

ELECTRO-HEAT FIN-CORE UNIT

3. REPLACE OLD THERMOSTATS WITH NEW THERMOSTATS.

Electric baseboards use on-off thermostats that are classified as line voltage (120V) or low voltage (30V or less). Low voltage thermostats, which require a transformer and relay, control temperature more precisely in larger rooms. Electric baseboards are usually controlled with remote wall-mounted thermostats but many are available with built-in line-voltage thermostats. Built-ins are subject to temperature extremes and therefore do not sense room temperature accurately. Either type should contain a small, internal, anticipation heater, which increases the cycle rate to result in more accurate control of space temperature. An automatic setback thermostat with a clock to control the heater can reduce energy costs.

ADVANTAGES: Appropriate and well functioning thermostats can maintain comfort zones more accurately.

DISADVANTAGES: Replacement does not significantly affect energy savings.

4. SUPPLEMENT EXISTING ELECTRIC BASEBOARD HEAT WITH ADDITIONAL HEATING SYSTEM.

There are instances in which an electric baseboard system can no longer economically provide for the heating needs of a home (i.e. a seasonal home now used as a fulltime residence). One solution is to add an auxiliary heat source to electric baseboard heating, such as a gas furnace and ducts (which can also distribute cooling); pellet stove; coal stove (a relatively low-cost fuel, although dirty); oil stove; kerosene stove; unvented gas heater or gas log in the fireplace; through-wall, Cadet-type heaters; or fan heaters. Adding a wood stove can be economical. *Volume 8: HVAC/Plumbing* discusses such options in detail.

ADVANTAGES: Energy savings can be significantly increased while retaining some advantages of electric baseboard heating.

DISADVANTAGES: Dependence upon availability of fuel; higher maintenance; usually less energy efficient than complete replacement of electric baseboard system.

5. REPLACE EXISTING BASEBOARD HEAT WITH MORE EFFICIENT SYSTEM.

Conversion to a gas- or oil-fired system may be cost-effective from the standpoint of energy costs. The economics of fuel-switching will vary per house, so an analysis and estimate should be conducted (see *Volume 8: HVAC/Plumbing*). For small rooms, installing radiant electric panels is more energy efficient, provides more even heat distribution, and heats the room faster than electric baseboards.

ADVANTAGES: Conversion can offer substantial energy savings, especially in cooler climates.

DISADVANTAGES: First costs will be higher than electric baseboards. New system may require ductwork. A zoned system will have to be installed to approach the flexibility of electric heating.

FURTHER READING

1996 ASHRAE Handbook, HVAC Systems and Equipment, Atlanta, GA: ASHRAE, 1996.

Simplified Design of HVAC Systems, William Bobenhausen, New York: John Wiley and Sons, Inc., 1994.

This Old House: Heating, Ventilation, and Air Conditioning, Richard Trewethey with Don Best, Little, Brown, 1994.

"Saving Energy with Electric Resistance Heating," Energy Efficiency and Renewable Energy Network, US Department of Energy; www.eren.doe.gov/erec/factsheets/elecheat.html.

PRODUCT INFORMATION

Electro-Heat, Inc., P.O. Drawer D, Hwy M-222, Allegan, MI 49010; 616-673-6688; www.accn.org/~ehinc/finned.htm.

Radiant Electric Heat, Inc., 10866 West Wisconsin Ave., Wauwatosa, WI 53226; 800-774-4450; www.electrichheat.com.

Markel Baseboard Heaters, 470 Beauty Spot Rd. East, Bennettsville, SC 29512; 803-479-4006; www.marleymeh.com.

Enerjoy by SSHC, Inc., PO Box 769, Old Saybrook, CT 06475; 800-544-5182; www.sshcinc.com.

Runtal North America, Inc., 187 Neck Rd., Ward Hill, MA 01835; 800-526-2621.

Cadet Manufacturing Co., P.O. Box 1675, Vancouver, WA 98668; 800-442-2338.

Q-Mark by Staley Electric Supply, 611 Fayette St., Conshohocken, PA 19428; 610-825-6482; www.membrane.com/philanet/staley/qmark.html.

7

PHONE/COMPUTER/ TV CABLING

ESSENTIAL KNOWLEDGE

A phone circuit consists of a low voltage electrical loop. A pair of wires running parallel are necessary to accommodate single-line voice communication. Much of today's analog station wiring (residential telecommunication wiring) of the "plain-old telephone system" (so-called POTS) consists of either two, three, or four (so-called "quad wire") insulated conductors running parallel, bunched together and jacketed (Fig. 1). These wires were designed to meet minimum analog voice requirements, but interference from motors, power circuits, or "crosstalk" noise (hearing another phone conversation) is likely, caused by the partial transfer within the cable of a signal from one circuit to another. With the proliferation of phones and modems devices the telecommunications industry developed the economical, unshielded twisted pair (UTP) concept to minimize interference. The paired conductors, usually #24 AWG or #26 AWG (American Wire Gauge), are twisted together at regular intervals (Fig. 2). In a cable with multiple pairs, this helps isolate and preserve the signals being sent. Some newer telephones and more sophisticated telephone systems will not work properly unless connected to a UTP type wire.



FIGURE 1

PLAIN-OLD TELEPHONE SYSTEM WIRING

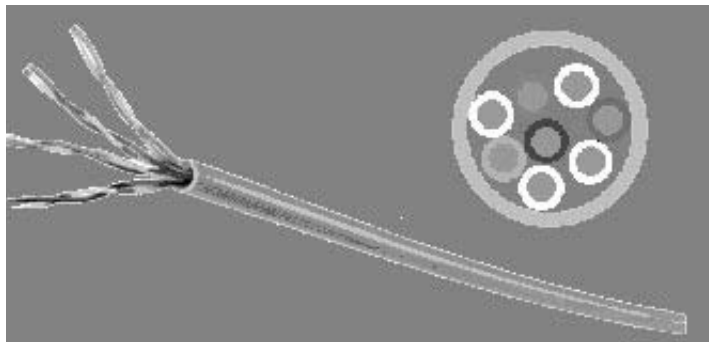

FIGURE 2

UNSHIELDED TWISTED PAIR WIRING

Each cable has a UL fire rating for the outer insulation jacket (2 or 3). Level 2 is accepted for residential use in many areas and level 3 complies with almost all local building codes. Consult with a building official for local requirements.

In response to the ever-growing wire market, the Telecommunications Industry Association (TIA) and the Electronic Industries Alliance (EIA) established a standard for a generic cabling system that can accommodate many applications. The different telecommunication wires (sometimes called “JK”) are rated by category, specifying the number of twists each pair has per unit of length (CAT 1, 2, 3, 4, 5, 5e, 6). The tighter the pairs are twisted together, the higher the performance and signal quality. Today’s residential phone systems usually share wires with home computers connected to the internet or LAN and therefore not only have to accommodate new digital phone systems but also digital computer transfer signals (ISDN, which will eventually be succeeded by ADSL).

The more bandwidth (indicated in megahertz [MHz]) a wire has the more data it can transfer. Phone wire performance ranges from the common CAT 1 (1 MHz), and its popular 100 MHz successor CAT 5 UTP, all the way to the 250 MHz CAT 6, at the time this volume was prepared. Today CAT 5 is widely accepted as the standard for most current and foreseeable residential communication needs. Compared to the four megabytes per second data transfer of CAT 1, the 40% higher priced CAT 5 has a data transfer rate starting at 100 megabytes per second (Mbps) up to over 150 Mbps, depending on the manufacturer. Some companies market signal enhancers and accelerators as an alternative to cabling upgrades. Such devices have been proven ineffective, however. Shielded wires are not necessary as long as a minimum CAT 3 is used.

The search for the source of problems such as interference, static, etc. should start where the phone cable enters the home, namely the NID (Network Interface Device). Cable from this device out to the pole is the phone company’s responsibility and is covered by the “connection charges” for having new or additional service installed. If there is a dial tone at the NID, the phone company has met its obligation (for test procedures and equipment, see PRODUCT INFORMATION). Cable from the NID to the telephone sets is the responsibility of the customer, and it is at his or her discretion how repair work is accomplished. If wiring and cabling problems persist most phone and TV cable companies provide a maintenance contract where, for a monthly fee, the company takes repair responsibility beyond NID. Phone companies also answer individual service calls but usually bill hourly and may therefore not be as cost effective as a local installer.

In TV cabling, the common 20-gauge RG-59 coaxial cable (composed of two conductors and several layers of insulation) served the industry when there were only Channels 2 through 13 in the TV spectrum. RG-59 is being replaced by the better performing 18-gauge RG-6 coaxial cable (at the same price). With today’s high-frequency channels and the growing demand for Digital Satellite Systems (DSS), High Definition Television (HDTV), and interactive services such as video-on-demand and WebTV, homes need cable with greater bandwidth and dependability. RG-6 doubles the capacity of RG-59 and is usually protected by four separate electronic shields (quad shielded) to ensure minimal signal loss and interference. The performance and reliability of RG-6 depends on the manufacturer. Typical aging problems, such as brittle insulation or bare wire, are similar to phone, computer, and electrical wiring.

TECHNIQUES, MATERIALS, TOOLS

1. REPAIR CRACKED INSULATION OR FRAYED WIRE

Crumbling insulation can temporarily be repaired by wrapping the bared wires with electrical tape. However, kinks, crimps, splices, or too much twisting out can ruin the performance of CAT 5 wire and RG-6 cable.

ADVANTAGES: Repairing insulation with electrical tape is significantly less costly than rewiring.

DISADVANTAGES: Compared with rewiring, this fix is short-term. Splicing or using electrical tape significantly decreases signal quality and performance.

2. REWIRE WITHIN EXISTING WALLS/CEILING.

The most cost-effective way to solve telecommunication wiring problems such as inadequate bandwidth, interference, and deteriorating wiring insulation is to rewire. Unless only single-line analog voice service is necessary, TIA does not recommend using CAT 1 wiring. Currently the trend is to install CAT 5 for both current and future data and voice transmissions. In TV cabling RG-6 replaces the existing coaxial cable

RG-59 for the same price. Selecting which wires and terminators in the home are to be updated is critical, since a phone and TV system's performance is only as good as its weakest component. For optimal performance and fire code compliance consult your local telecommunication and TV cabling expert.

It may be possible to use the existing wire as a guide to bring a new cable through the wall. If not, the wire must be snaked through the wall and/or ceiling cavities. Due to possible transmission interference, avoid running telecommunication wiring closer than 2" parallel to electrical wiring, do not cross wires at 90° angles, and do not share bore holes or studs for outlets. If baseboards can be removed, wires can run within the baseboard-wall cavity. Under certain circumstances wires can also be run underneath wall-to-wall carpet. **ADVANTAGES:** Most effective short- and long-term fix. Most wire problems are eliminated and performance is upgraded.

DISADVANTAGES: Rewiring within existing walls and ceilings is cumbersome and can be costly.

2. REWIRE USING CABLING RACEWAYS

Cabling raceways provide a way to rewire without having to snake through walls or ceilings. The raceways are mounted on interior walls and can encase electrical and communication wires (Fig. 3) However, telecommunication/TV cabling should not be run in the same raceway as electrical wiring unless the raceway has been designed for dual use. PVC raceways are available in white or wood laminate versions.

ADVANTAGES: Cabling raceways can simplify the task of rewiring and reduce wall penetrations that can compromise a building's thermal performance. Wiring in raceways is accessible for future changes; locations of jacks can also be changed.

DISADVANTAGES: Separate raceways for electrical and telecommunications/TV have to be installed unless the raceways are designed to accommodate both. This fix may not be aesthetically acceptable.



FIGURE 3

ELECTRICAL & COMMUNICATION WIRING RACEWAY

FURTHER READING

Residential Cabling System, P.O. Box 57, Ayer, MA 01432-0057; 978-772-5700; www.residentialcabling.com.

"Wired For The Future," *Builder*, September 1998, www.modeling.hw.net/hometech/wiring/1/.

Better Homes and Gardens Online Encyclopedia, www.bhglive.com/homeimp/wiring.html.

PRODUCT INFORMATION

Leviton Manufacturing Company Inc. 59-25 Little Neck Parkway, Little Neck, NY 11362; 800-824-3005; www.leviton.com.

Residential Cabling System, P.O. Box 57, Ayer, MA 01432-0057; 978-772-5700; www.residentialcabling.com.

8

SECURITY SYSTEMS

8.1

INTRUSION AND ALARM SYSTEMS

ESSENTIAL KNOWLEDGE

Intrusion detection and alarm systems can share components with smoke/gas detection systems, pipeburst/flood detection (see *Volume 8: HVAC/Plumbing*), closed circuit television, child-tracking devices, or keyless entries/access control systems. Sensors can be located on the interior or around the perimeter of the building. When a sensor is activated, it sends a signal to a control panel, which triggers a siren and/or notifies a central monitoring station, automatically dispatching police, fire, or medical help as necessary.

Components of an intrusion detection system include: (1) the control panel, a hidden box that receives information from the sensors and transmits the alarm (signals can also be sent to a central station, indicates the area of the building in which the alarm originated); (2) the arming station (also called master station, remote station, or touch pad) turns the system on and off (it is usually a remote keypad with LED or LCD display, but can be linked to touch screens, panic buttons, TV screens, computers, telephones, or handheld remotes); and (3) sensors send signals to the control panel (several types of sensors are used for intrusion detection: magnetic contacts signal when the door or window is opened; glass-break sensors protect windows, sliding glass doors, and skylights, and are activated either by the shock of glass breakage or the sound of breakage; passive infra-red sensors detect the presence of an intruder by comparing body heat to ambient temperature in occupied space; motion sensors detect movement in the area of coverage; combination, or dual technology, sensors [Fig. 1] detect two activities, for example glass-break and motion detection, which helps prevent false alarms).

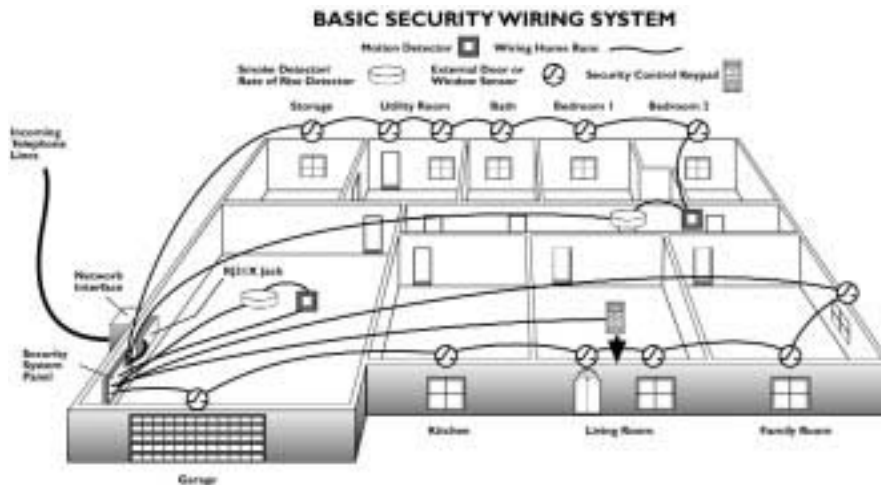

FIGURE 1

COMBINATOR SENSORS

4. REPLACE WIRING.

This is often feasible when the scope of home rehab involves cutting electrical lines. Incorrectly spliced wire, without sufficient solder and electrical tape, is a common cause of false alarms. Attempting to salvage old lines may cost more in labor than installing new wiring. Replace wiring if the insulation is brittle, such as near the contacts where it is exposed. Concealed wiring may require some removal of interior finishes; coordinate with drywall installation.

ADVANTAGES: Can reduce incidence of false alarms or activation failures.

DISADVANTAGES: Usually the most costly part of the system.

5. REPLACE ENTIRE SYSTEM.

This may be necessary when, for example, wireless components are installed, which often don't interface with older systems. Systems older than the mid-1980s will need replacement; they used 3V to 6V drycell batteries, whereas 12V rechargeable batteries are now used. The National Electrical Code has recently been updated with respect to low-voltage and limited-energy systems. Installing a new security system is an opportunity to integrate other home automation features. Although many installers routinely will run four- or six-conductor cable, it is worth specifying as it provides added flexibility at a small upcharge. Installation contracts for \$100 that come with a three-year, \$30/month monitoring contract may be desirable. Without such a contract, installation may be \$400+, with service calls at an hourly rate.

ADVANTAGES: Affords the opportunity for utilizing the latest security technology and integrating with other advanced wiring systems. Deep discount if purchased with contract.

DISADVANTAGES: Contract payments may be costly.

FURTHER READING

Safe & Sound, Your Guide to Home Security, National Burglar and Fire Alarm Association.

"To Foil a Thief," *Consumer Reports*, September 1998.

The Guide to Low-Voltage and Limited Energy Systems, National Electrical Contractors Association, 1999.

Residential and Light Commercial Installation Practices (TIA-570 Compliance), Leviton Manufacturing Co., Inc., 1998; www.levitontelcom.com/pdf/strat_bk2.pdf.

Understanding and Servicing Alarm Systems, Second Edition, H. William Trimmer, B.S., Butterworth Heinemann, 1989; www.bhusa.com.

Electronic Security Systems Pocket Book, Gerard Honey, Butterworth Heinemann, 1999.

Security Systems & Intruder Alarms, Second Edition, Vivian Capel, Butterworth Heinemann, 1999.

Security: A Guide to Security System Design and Equipment Selection and Installation, Second Edition, Neil Cumming, Butterworth Heinemann, 1994.

Intrusion Detection Systems, Second Edition, Robert Bernard, Butterworth Heinemann, 1988.

PRODUCT INFORMATION

ADEMCO, 165 Eileen Way, Syosset, NY 11791, 516-921-6704.

AMP Incorporated, MS 258-15, PO Box 3608, Harrisburg, PA 17105-3608; 717-985-2355; www.amp.com.

Applied Future Technologies, Inc., 6378 South Benton Way, Littleton, CO 80123; 303-403-0457; www.appliedfuture.com.

Axlon Electronics Corp., 5F-5, 77, Sec. 1, Hsin Tai Wu Road, Hsi-Chi, Taipei, Taiwan, ROC, 866-2-26983336; www.axlon.com.

Caddx Controls, Inc., 1420 N. Main Street, Gladewater, TX 75647; 800-727-2339; www.caddx.com.

C&K Systems, Inc., 625 Coolidge Dr., Folsom, CA 95630; 916-985-0352 fax; www.cksys.com.

Digital Security Controls Ltd., 1645 Flint Road, Downsview, ON M3J 2J6, Canada; 416-665-8460 x442; www.dscltd.com.

First Alert Professional Security Systems, 175 Eileen Way, Syosset, NY 11791; 800-793-5949; www.firstalertpro.com.

Home Automation, Inc., 3900 Barrett Drive, Suite 206, Raleigh, NC 27609; 919-782-6961; hai-dh@mind-spring.com.

Interactive Technologies, Inc., 2266 Second St. No., North St. Paul, MN 55109; 888-484-2806; www.ititechnologies.com.

Napco Security Systems, Inc., 333 Bayview Ave., Amityville, NY 11701; 800-645-9445.

US TEC, 100 Rawson Road, Suite 205, Victor, NY 14564; 716-924-1740; 716-924-7498; e-mail: Ustec@aol.com.

X-10 (USA) Inc., 91 Ruckman Road, Box 420, Closter, NJ 07624-0420; 201-784-9700 x20; e-mail: dav-erye@aol.com.

8.2

SMOKE DETECTORS

ESSENTIAL KNOWLEDGE

Smoke and fire detectors have saved thousands of lives since being introduced to the residential market in the 1970s. In spite of the increase in the number of homes since then, the number of fire-related deaths has decreased steadily.

There are three types of detectors: photoelectric, ionization, and heat-sensing. Most photoelectric devices work on the principle of detecting the presence of light due to its scattering by smoke particles. In the absence of smoke, light from an LED passes right through the detection chamber (Fig. 4) without triggering a response from the light sensor. When smoke enters the chamber, the light scatters onto the photo detector, triggering an alarm. This kind of detector is sensitive to slow smoldering fires that produce large-sized smoke particles. In another type of photoelectric device, the smoke entering the chamber also blocks a light beam, but in this case the reduction in light reaching a photocell sets off the alarm.

Ionization smoke detectors sense fires by relying on the atomic neutralizing property of smoke. The ionization chamber (Fig. 5) has two plates with a small amount of voltage applied to them. One of the plates has a hole with radioactive material on the other side (approximately 1/5000 gram of Americium 241). The alpha particles generated by the Americium ionize the oxygen and nitrogen atoms. These ionized atoms are attracted to the plates and generate electric current. Smoke particles fill the chamber and attach themselves to the ionized atoms, thus neutralizing them. This disrupts the flow of current in the circuit, which is detected as smoke. This kind of detector is sensitive to fast flaming fires that produce small-sized smoke particles.

Heat detectors are available combined with a smoke detector or as a separate product. They are useful where smoke detectors have false alarms, such as in kitchens, as well as areas too hot or too cold for smoke detectors. Heat detectors depend on a fusible link made of lead that distorts with rising temperatures. There are two types of heat sensors. The “fixed” temperature sensor triggers an alarm when it detects a certain air temperature. This is the most common type for residential applications. “Rate-of-rise” sensors depend on a thermostat which detects a percentage temperature rise over a few seconds. Heat

detectors either sound their own alarm or a central alarm if part of a system. Heat detectors must be very close to a fire to be set off, and are therefore not effective early-warning devices. Heat detectors are long-lived (unless triggered), have few false alarms, and are relatively unaffected by cooking grease. However, it is necessary to install a new unit after the device has sensed a single fire.

Detectors are battery powered or hardwired, or a combination of both. Hardwired detectors are either connected to a 120-volt home circuit in series or stepped down to low voltage in a home run to a control box when interconnecting to a low-voltage security system. The National Fire Protection Association (NFPA) safety standard recommends at least one detector on each level of the house. Ideally, each bedroom should have a detector, one outside the bedroom area, one in the living area, and one in the kitchen. It is extremely important to locate the detectors properly to provide good coverage.

Although alarms for the hearing-impaired are not required for residences, the Americans with Disabilities Act and the National Fire Protection Association suggest strobe light or vibration systems, should they be installed. The vibration system works with a transmitter relayed at the fire panel to send a signal to a bedside receiver that vibrates the bed. Available for new systems or retrofit to existing, vibration systems are more expensive but are considered more likely to wake residents than strobe lights.

“Smart” fire detectors that minimize false alarms are now in development. Smart detectors use a combination of detection methods and a microprocessor to “decide” when to alarm. The National Institute of Standards and Technology (NIST) Building and Fire Research Laboratory has developed a flow tunnel to test smart smoke detectors.

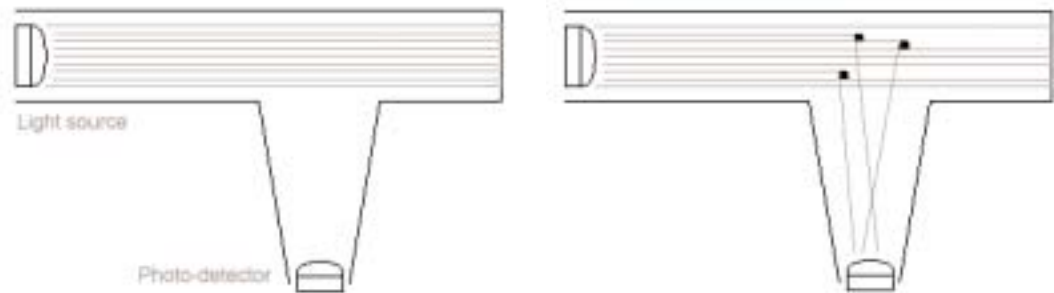

FIGURE 4

PHOTOELECTRIC SMOKE DETECTION CHAMBER, CLEAR AND PARTICLE FILLED

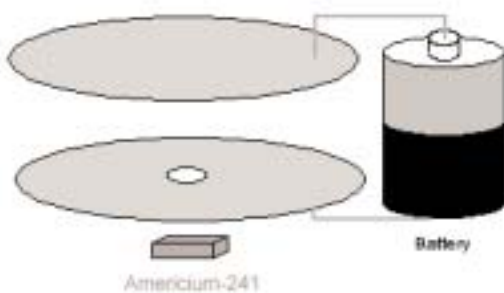

FIGURE 5

IONIZATION SMOKE DETECTOR COMPONENTS

TECHNIQUES, MATERIALS, TOOLS

1. MAINTAIN EXISTING SMOKE DETECTOR.

Battery-powered smoke detectors will beep at regular intervals if the battery needs changing. It is imperative that batteries be changed once or twice a year to avoid failed detection. Follow manufacturer’s recommendations for battery size and voltage. Smoke detectors have an aspirated opening to facilitate free flow of indoor air. These openings can get clogged from the accumulation of dust and cooking grease, preventing smoke entry and detection. Detectors should be cleaned regularly to avoid such build up. Care should be taken when cleaning ionization smoke detectors; the sealed chamber containing radioactive

material should not be opened or serviced. Even though there is a small amount of radioactive material in the chamber and a sheet of paper can block the alpha particles generated by it, it is dangerous if inhaled or swallowed. Follow manufacturer's cleaning recommendations.

ADVANTAGES: Least expensive response.

DISADVANTAGES: Risk of old detector not performing properly, even after maintenance.

2. REPLACE EXISTING SMOKE DETECTOR WITH NEW UNIT.

The *1999 National Fire Alarm Code* requires smoke detectors to be replaced every 10 years. During this time they have gone through 3.5 million monitoring cycles and are more likely to fail in the case of a real fire. Although most home fires respond to photoelectric sensors, a combination of sensor types is the best strategy for covering all kinds of fires and contingencies. Using both battery operated and 120-volt units will detect fires during a power outage and if there is a failed battery. It is also recommended that all smoke detectors in a home be interconnected; in the event of a fire in any part of the house, all alarms will activate to alert the occupants. In a household with a hearing impaired person, visual alarms with strobe lights should be additionally installed. According to the NYC Health Department Radiation Division, there are no federal disposal precautions for ionization smoke detectors.

ADVANTAGES: Opportunity for reliable, properly-specified system.

DISADVANTAGES: More costly solution.

FURTHER READING

"Cleaning and Testing Smoke Detectors," *Security Professional*, August 1999.

Guide to Low-Voltage and Limited Energy Systems. National Electrical Contractors Association, 1999.

"How Smoke Detectors Work," www.howstuffworks.com.

NFPA 72: National Fire Alarm Code, 1999 Edition, Chapters 1, 7, 8, National Fire Protection Association.

NFPA 101: Life Safety Code, National Fire Protection Association.

Safe & Sound, Your Guide to Home Security, National Burglar and Fire Alarm Association.

Understanding and Servicing Alarm Systems, Second Edition, H. William Trimmer, B.S., Butterworth Heinemann, 1989, www.bhusa.com.

What You Should Know About Smoke Detectors, U.S. Consumer Product Safety Commission, January 1985, www.ag.ohio-state.edu/~ohioline/aex-fact/0690_1.html.

"Working Knowledge: Smoke Detectors," *Scientific American*, April 1997, www.sciam.com/0497issue/0497working.html.

PRODUCT INFORMATION

ESL/Sentrol, 12345 SW Leveton Dr., Tualatin, OR 97062-9938; 800-547-2556; www.sentrol.com.

System Sensor, 3825 Ohio Ave., St. Charles, IL 60174; 800-SENSOR2; www.systemsensor.com.

Gentex, 10985 Chicago Dr., Zeeland, MI 49464; 800-436-8391; www.gentex.com

Edwards Signaling Products, 90 Fieldstone Ct., Cheshire, CT 06410-1212; 203-699-3000; www.edwards-signals.com.

Kidde-Fenwal, Inc., 400 Main St., Ashland, MA 01721; 800-872-6527; www.Kidde-Fenwal.com.

MTI Industries, Inc., 31632 N. Ellis Dr., No. 301, Volo, IL 60073; 800-383-0269; www.safe-t-alert.com.

Vibration systems: Silent Call Communications Corp., 2220 Scott Lake Rd., Waterford, MI 48328; 800-572-5227; www.silent-call.com.

ESSENTIAL KNOWLEDGE

Carbon monoxide, known by its chemical name, CO, is a gas generated during most combustion processes. The amount of CO increases with the scarcity of oxygen, leading to partial combustion of carbon, producing CO instead of CO₂ (carbon dioxide). CO is deadly in long-term exposure even in low concentrations. CO forms a chemical bond with hemoglobin in the blood, which is stronger than the bond between oxygen and hemoglobin. Either high concentration or long-term exposure to CO removes oxygen from the blood stream, leading to possible death.

CO is generated in toxic quantities in homes that have one or more combustion devices such as gas ovens, gas cooking ranges, gas or oil water heaters, gas or oil furnaces, and gas or wood fireplaces with inadequate air for the combustion process. Poor maintenance of combustion devices, cracked heat exchangers, blocked chimneys, leaky furnaces, running automobiles in enclosed spaces, and indoor barbecues can aggravate the CO problem.

Homes without combustion devices have a CO concentration of 0.5 to 5 ppm, which is about the same as outdoors. However, CO levels above 15-20 ppm over long periods can be deadly. CO detectors should be able to detect the concentration as well as the duration of exposure to protect the occupants. All CO detectors should be UL 2034 approved, which requires the detector to activate an alarm if the CO level reaches 100 ppm for 90 minutes.

There are presently three CO detection methods commonly available for residential use: (1) Biomimetic sensors mimic blood reaction to CO with color changes sensed by a photocell that triggers an alarm. Sensors must be changed at intervals; (2) electrochemical sensors react with CO to produce a small charge that corresponds to the CO level. This type of sensor loses sensitivity after approximately two years and needs replacement; (3) solid state, also called semiconductor or conductometric, sensors, measure changes in electrical resistance of a material that absorbs CO.

Infrared (IR) sensors are calibrated to detect specific gases. When used for CO detection, they constantly bombard air samples with IR radiation and then look for the radiation signature of CO molecules. These sensors are accurate and more stable over longer periods than other detection methods. IR gas detection has industrial applications but is too expensive for most residential use. Some of the “smart” detectors being tested by NIST incorporate CO detection in addition to advanced smoke detection.

TECHNIQUES, MATERIALS, TOOLS**INSTALL A CO DETECTOR.**

CO detectors are either battery powered or hard-wired into the home's 120-volt or low-voltage circuit. Batteries should be replaced every year to avoid failed detection. The best approach is a hard-wired detector with a battery backup to ensure proper functioning under all conditions. Ideally, CO detectors should be on each floor of a home, in each sleeping area, and outside any room where combustion devices are located.

ADVANTAGES: Provides a means for monitoring a dangerous gas.

DISADVANTAGES: Reliability of products varies widely.

FURTHER READING

NFPA 720: Recommended Practice for the Installation of Household Carbon Monoxide (CO) Warning Equipment, 1998 Edition, National Fire Protection Association.

“UL 2034-98: Carbon Monoxide Alarm (CO) Standards,” Underwriters’ Laboratories, 1998.

“GRI Technical Report: Performance Testing of Residential CO Alarms,” Gas Research Institute, 1999.

“Sleeping Safely,” *Consumer Reports*, November 1996, www.consumerreports.org/Special/Samples/Reports/9611.det0.htm.

PRODUCT INFORMATION

MTI Industries, Inc., 31632 N. Ellis Dr., No. 301, Volo, IL 60073; 800-383-0269; www.safe-t-alert.com.

Kidde-Fenwal, Inc., 400 Main St., Ashland MA 01721; 800-872-6527; www.Kidde-Fenwal.com.

First Alert, 3901 Liberty St. Rd., Aurora, IL 60504; 800-323-9005; www.firstalert.com.

BRK Brands, Inc. 3901 Liberty St Rd, Aurora, IL, 60504-8122; 630-851-7330; www.firstalert.com.

Macurco Gas Protectors, 3946 So. Mariposa St., Englewood Co 80110; 303-781-4062; www.macurco.com.

ESL/Sentrol, 12345 SW Leveton Dr., Tualatin, OR 97062-9938; 800-547-2556; www.sentrol.com

Aim Safety USA Inc., 8403 Cross Park Dr., #1A, Austin, TX 78754; 800-275-4246; www.aimsafeair.com.

8.4

LIGHTNING PROTECTION

ESSENTIAL KNOWLEDGE

Lightning is a random, capricious phenomenon that results in more deaths than hurricanes and floods combined and damages approximately 18,000 homes annually in the U.S. Lightning strikes the Earth up to 100 times a second. Lightning can carry up to 400,000 amps, can produce up to 30 million volts, and can reach temperatures of 50,000°F. Lightning occurs when buildup of electric potential (usually negative charge) in storm clouds sends downward “leaders” that connect with “streamers” sent up by ground objects of positive charge. Direct effects of lightning are caused by resistance and include ohmic heating, arcing, and fires. Indirect effects are capacitive, inductive and magnetic behaviors occurring in certain locations, causing electrical surges leading to fire or breakdown of household electronic devices.

Properly designed protection systems (Fig. 6) have been documented by Underwriters’ Laboratories (UL) to be over 99% effective in preventing direct damage by lightning. A system consists of five components: (1) collection devices to direct lightning away from the structure and into the ground (these devices include lightning rods or “air terminals,” Faraday’s cages, shielding wires, etc., each made for a specific purpose); (2) cables to interconnect collection devices and download conductor cables to route lightning between collection devices and down to the grounding (any bends in the cable should not be too sharp [Fig. 7] to prevent “flashover” of lightning to nearby objects); (3) interconnection to metal parts on the roof or within the building; and (4) grounding rods to dissipate lightning into the earth once it has traveled down the building. Single point (Fig. 8) or multiple point grounding systems can be used, depending on ground resistance, water table and soil characteristics. Avoid placing multiple point grounding rods so close that they allow saturation of the ground—UL requires minimum 10’ separation between multiple grounds. Preferably, each rod should have counterpoise (also called fork-type or crow’s foot) radial branches to reduce impedance. The system should share common grounding with electric and telephone ground, and metallic water and gas pipe according to code; and (5) secondary lightning surge arresters on the main electric panel, telephone line entrance, and radio and TV antenna lead-in.

Model and state building codes do not require the installation of lightning protection systems. All lightning codes (Underwriters’ Laboratories UL96A, National Fire Protection Association Standard NFPA780, and Lightning Protection Institute Standard of Practice LPI-175) function as guidelines. However, some local codes, such as in Florida, are incorporating requirements for lightning protection to reduce fires resulting from lightning strikes.

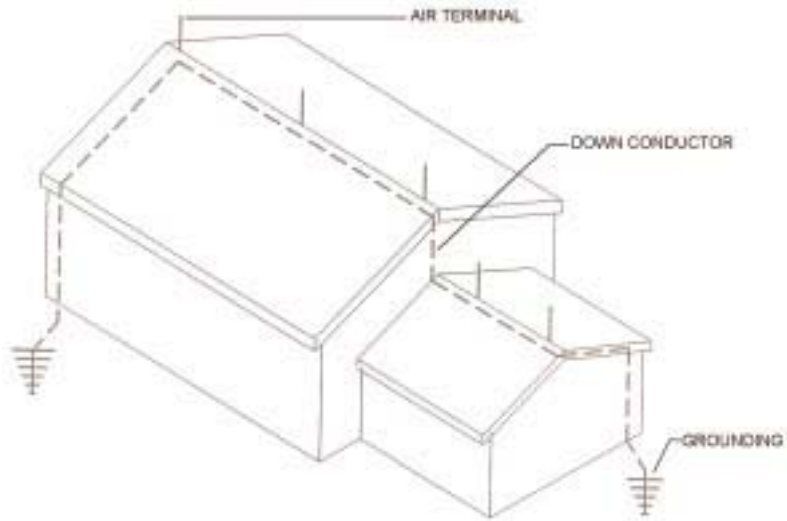

FIGURE 6 LIGHTNING PROTECTION SYSTEM

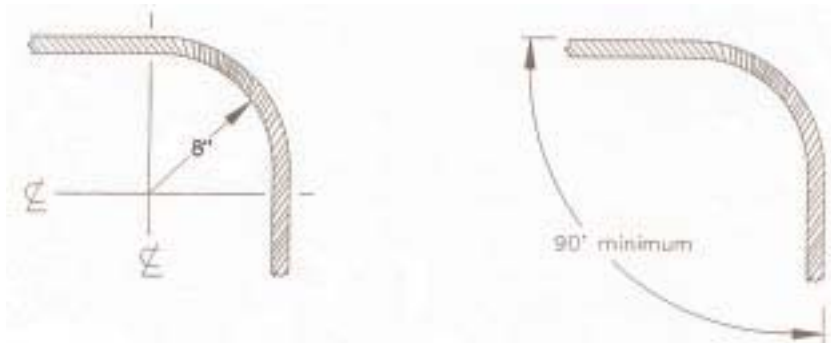

FIGURE 7 MAXIMUM BENDS IN CABLE

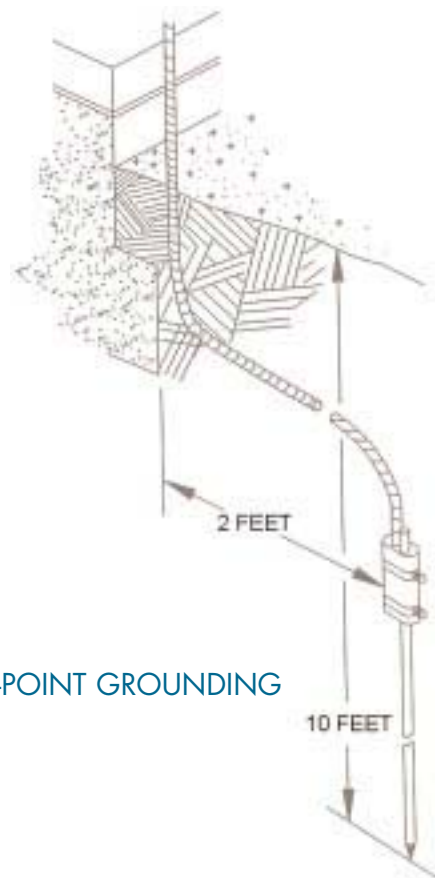

FIGURE 8 SINGLE-POINT GROUNDING

TECHNIQUES, MATERIALS, TOOLS

1. MAINTAIN EXISTING LIGHTNING PROTECTION SYSTEM.

The lightning protection system should be inspected at least once every two years; utility service companies may have altered the grounding or severed down conductors. Besides a visual check, the inspection should include: (1) bonding resistance test, which rates the resistance of each bond along the path of the lightning protection system. Each bond is allowed a maximum of one ohm; and (2) “resistance to earth” test, which measures net resistance of the total path from air terminal to the ground. Resistance to earth records should be kept for at least six cycles to note any trends. Do not paint the down conductor, as the increased resistance can cause a fire.

ADVANTAGES: Least expensive option if existing system is adequate to offset local risk.

DISADVANTAGES: Existing system may not be UL- or code-compliant. May not account for current conditions, such as adjacent tree growth, building additions, or construction/demolition of nearby buildings.

2. INSTALL NEW MATERIALS ON EXISTING LIGHTNING PROTECTION SYSTEM.

Systems are custom designed and any existing system can be repaired or added to in a modular way with new components. Replacement components can be semi-concealed if the attic is accessible; down conductors can be routed behind rain leaders or trim boards. Most modifications to existing systems are intended to bring a system up to UL standards or to comply with code changes. The National Electric Code is now in agreement with the Lightning Protection Code, which requires that underground service line grounds be connected in series. UL calls for tying electrical, phone, and cable grounds together with gas and plumbing grounds since telephone grounding, often poor, is a common source of damage. Secondary lightning surge arresters, located at electrical and phone service panels, have been code-mandated since the early 1970s for homes with lightning protection. Insurance companies used to offer discounts or credits for UL-approved lightning protection, but since deductibles have become common, homeowners are motivated to install reliable, UL-approved lightning protection to avoid paying deductibles.

Adjacent trees may have grown considerably since the system was installed. Lightning protection, which does not harm the tree, is routed along the trunk and main boughs and is recommended by UL, NFPA, and LPI for valuable trees and those taller than, and within 10' of, any part of the building.

ADVANTAGES: An old system can be updated to perform like new at modest cost. Can protect trees or parts of a structure added after the existing system was installed.

DISADVANTAGES: If materials or configuration of existing system are inferior or incorrect, a new system may offer better protection.

3. INSTALL NEW LIGHTNING PROTECTION SYSTEM.

NFPA 78 includes a Risk Assessment Guide that helps determine whether a lightning protection system is cost-effective for a particular building and location. In general, taller structures relatively isolated from buildings nearby are more likely to be hit, particularly in areas that receive frequent storms. Systems can often be semi-concealed for a modest upcharge, hidden by the roof and building finishes, with only the 10"-high air terminals visible. Reinforcement bars in concrete should not be used for grounding the lightning protection system; lightning strikes produce enough heat to evaporate the moisture in the concrete, causing it to crack. TV and cable TV antennae, though grounded, do not offer lightning protection.

ADVANTAGES: Can limit injury and property damage, and add value, lasting as long as the home. Best opportunity to conceal down conductors.

DISADVANTAGES: Most expensive option in the short term.

FURTHER READING

NFPA78: Lightning Protection Code, National Fire Protection Association.

NFPA780: Standard for Installation of Lightning Protection Systems, 1997 Edition, National Fire Protection Association.

UL96A: Lightning Protection Standards, Underwriters' Laboratories.

LPI-175 Installation Standard, Lightning Protection Institute.

LPI-176 Components Standard, Lightning Protection Institute.

"Lightning: Its Behavior and What to Do About It," by H.M. Towne, United Lightning Protection Association, Inc., 1956.

PRODUCT INFORMATION

Independent Protection Company, 1603-09 South Main St., Goshen, IN 46526; 800-860-8388; www.ipclp.com.

Advanced Lightning Technology, Inc., 122 Leesley Lane, Argyle, TX 76226; 800-950-7933; www.advanced-lightning.com.

Automatic Lightning Protection, 7548 West Bluefield Ave., Glendale, Arizona 85308; 800-532-0990; www.lightningrod.com.

Lightning Master Corp., 1920 Sherwood Street, Clearwater, FL 33765; 800-749-6800; www.lightningmaster.com.

Stormin Protection Products, 10749 63rd Way N., Pinellas Park, FL 33782; 888-471-1038; <http://members.tripod.com/~storminprotection>.

8.5

SURGE PROTECTION

ESSENTIAL KNOWLEDGE

Surges, or voltage transients, are very high pulses of voltage lasting less than a hundredth of a second. Surges are caused by induction (internal or external) and by power line transients. Whenever an inductive device, such as a motor, fan, air conditioner, or incandescent bulb is shut off, the electromotive force (EMF) causes a voltage surge. Lightning strikes induce voltage surge by causing nearby metallic objects, wires, and electronic equipment to generate voltage. A typical lightning strike 300' from a house will induce high transient voltage, and a strike near high-tension wires many miles away can surge into many homes. Also, normal utility operation carries surges from load fluctuations, transformer blowouts, and other events.

Though surges and fluctuations presented few problems until the 1980s, modern devices require today's homes to be wired differently. In addition to personal computers (PCs), information technology is being installed in many household devices, such as microwaves, vacuum cleaners, washers, dryers, telephones, and even alarm clocks. Though these microelectronics endow products with additional functions and convenience, they are highly susceptible to common variations in voltage which can affect their performance and shorten their life.

Homes built before the early 1970s may not have three-prong grounded receptacles, or may have three-prong outlets installed in a two-wire system (see Section 4.3: Receptacles). Many computers, peripherals, and other electronics are designed to send surges through the third prong to ground; if that path is broken, components can be damaged. The home's wiring may not be supplying power of correct polarity. The ground for the home's wiring may have high impedance, improper neutral-ground bonds, or ground loops that allow unpredictable voltages to remain on the grounding circuit. If any aspect of the wiring is questionable, an electrician should inspect it. Local codes and regulations may influence the extent of surge protection in a rehab since the utilities have some responsibility for such suppression. For example, the phone company should supply a properly-grounded network interface box.

Since appliances can also generate transients in a home's electrical system, some electricians recommend keeping sensitive devices plugged into a different circuit than inductive equipment with motors and high-amperage switching loads like portable heaters, electric frying pans, and toasters. A separate ground circuit for electronic equipment may need to be installed if the wiring does not allow separating them from inductive and switching loads.

Beyond the utilities' efforts, transient control should be designed and installed in two stages to suppress all surges. First, "whole house" surge protection, or breaker suppression, should be installed at the circuit breaker box or distribution panel to eliminate most incoming surges. It should be able to shunt surges away from power, telephone/modem, and cable lines. Alternatively, telephone surge suppression can be installed as a separate unit, at the telephone connecting block outside the house or apartment building. Second stage devices at plug outlets protect electronic circuitry from EMF induced inside the house wiring or from other surges. Surge suppressors incorporate a small disc called a metal oxide varistor (MOV) that absorbs excess energy. MOVs are rated by diameter, which corresponds to their energy-absorbing ability. The rated life of a cheaper surge suppressor, which may rely on only one or two MOVs, is limited to a few years when exposed to most residential circuits, and less if a series of large transients or lightning occurs. Better-quality units incorporate a more substantial combination of MOVs, zener diodes, avalanche diodes, and/or gas tubes. Surge suppressors should meet UL 1449 Standard, second edition.

Frequently lightning damage comes through the phone line, and modems are especially vulnerable. The telephone company should have installed a properly grounded network interface box (NIB), which contains a lightning protection device, outside the home. Plug-in communications surge protection devices are available.

Most operational difficulty, however, is caused by power interruptions, also called sags or brownouts, and not power surges or spikes. These sags cause data corruption in PCs. Surge suppressors do not protect against this largest problem in Internet connectivity, but battery-powered uninterruptible power supply units (UPS) do. UPSs come in three general types: (1) double conversion UPSs continually run the device through an output circuit converter, powered by a battery connected to line voltage; (2) standby supplies connect the device directly to line voltage, which also keeps the battery charged. When power is lost, the battery-powered inverter is switched on; and (3) a ferroresonant supply acts as a power conditioner with a microprocessor-controlled transformer between the device and line voltage. When power failure occurs, the inverter supplies power to the transformer.



FIGURE 9

BREAKER SURGE SUPPRESSOR

TECHNIQUES, MATERIALS, TOOLS

1. INSTALL NEW SURGE SUPPRESSION AT BREAKER PANEL.

Breaker, or hardwired, suppressors (Fig. 9) protect an entire building, often with better energy-absorbing capacity than plug-in suppressors. They are installed at the main service or at a subpanel, keeping the lead from the panel to the suppressor short and straight. Suppressors are available as series or parallel units. Series protectors are more expensive and require breaking the incoming line. Parallel protectors are usually installed on the load side of the main breaker and are more typical for residences. Breaker suppressor devices should provide protection for line to neutral, line to ground, and neutral to ground; a fuse or circuit breaker for overload protection; thermal overheating protection; and additional protection for telephone line and coaxial cable if needed. Rated clamping voltage should be no more than 280V, volt-amp rating of no less than 750,000VA, and a response time of three to five nanoseconds. Equipment liability insurance should be available; some manufacturers offer up to \$500,000 coverage with no deductible. Warranty should be either lifetime or at least five years; better-quality units last indefinitely.

ADVANTAGES: Significantly reduces the load on point-of-use surge suppression.

DISADVANTAGES: Installation requires an electrician. Does not provide uninterrupted power supply or protection from internally-induced transients; may not include dataline protection.

2. PROVIDE NEW UNINTERRUPTED POWER SUPPLY (UPS).

Many units include outlets dedicated for surge suppression, in addition to combination surge/power protection outlets. However, it may be more economical to buy separate units, as it is less expensive to replace a plug-in surge suppressor with a blown MOV than a UPS. Home office users may consider units with automatic data protection, which connects to the PC with a serial port and software that automatically saves and closes files during a blackout if the user is not present. When selecting a UPS, one should compare sensing time, transfer time, length of backup service, and output quality. It should accommodate a standard size gel-cell battery in an accessible compartment. Batteries must be replaced after three to six years and should be tested periodically. Standby power sources, as well as generators, are occasionally used but have a longer delay than UPS units, leaving devices less protected. Ferroresonant power conditioners are occasionally used where nearby industry or utility problems might create damaging interference. However, units without batteries do not protect against power loss such as sags and brownouts.

ADVANTAGES: Can provide various levels of point-of-use protection.

DISADVANTAGES: Models with additional features are costly; generally inadequate without a breaker suppressor.

3. PROVIDE NEW PLUG-IN SURGE SUPPRESSION.

Plug-in suppressors can react quickly and can protect against induced transients. Available as dual-outlet direct plug-in units or strips with 4, 6, 8, or more outlets, many units include modem/fax and/or coaxial surge protection. Units that suppress only dataline surges (or only coaxial surges) are available. Note that most surge suppressors will deliver power after the protection circuitry has been destroyed by a single lightning strike or repeated "hits" by high energy surges, reducing it to a mere outlet strip. High quality surge suppressors feature higher joule ratings, lower clamping response times, lower voltage clamping levels, both common-mode and normal-mode protection, and electromagnetic interference (EMI) and radio-frequency interference (RFI) filtering of incoming power. Units with these features will be the most costly.

ADVANTAGES: Inexpensively protects against induction surges.

DISADVANTAGES: Relatively short lived. Generally inadequate without a breaker suppressor.

FURTHER READING

NFPA 70, National Electrical Code Article 280: Surge Arresters, National Fire Protection Association.

UL 1449, Surge Suppression Standards, Second Edition, Underwriters' Laboratories.

PRODUCT INFORMATION

Volt Guard Inc., 400 23rd St. So., St. Petersburg, FL 33712; 800-237-0769; www.voltguard.com.

Panamax Inc., 150 Mitchell Blvd., San Rafael, CA 94903-2057; 800-472-5555; www.panamax.com.

Advanced Protection Technologies, 14088 Icot Blvd., Clearwater, FL 34620; 800-237-4567; www.ap-tbss.com.

Square D Co., 2001 W. 10th Pl., Tempe, AZ 85281; 602-968-3101; www.protek-tvs.com.

Best Power, P.O. Box 280, Necedah, WI 54646; 800-356-5794; www.bestpower.com.

Stormin Protection Products, 10749 63 Way N., Pinellas Park, FL 33782; 888-471-1038; <http://members.tripod.com/~storminprotection>.

Control Concepts, 328 Water St., P.O. Box 1380, Binghamton, NY 13902-1380; 607-724-2484; www.controlconcepts.com.

Tripp Lite Power Protection, 1111 W. 35th St., Chicago, IL 60609; 773-869-1111; www.tripplite.com.

American Power Conversion, 132 Fairgrounds Road, West Kingston, RI 02892; 401-789-5735; www.apcc.com.

Leviton Manufacturing Co. Inc., 59-25 Little Neck Parkway, Little Neck, NY 11362-2591; 800-323-8920; www.leviton.com.

8.6

GARAGE DOOR OPENERS

ESSENTIAL KNOWLEDGE

An electric garage door must serve two opposite functions: providing automatic entry for residents while maintaining a barrier to would-be burglars. Components of a typical garage door operator (Fig. 10) include: (1) an electrically reversible motor; (2) belt, chain, or screw drive. Belt drive is the quietest, but the neoprene belt material can break. Chains are common but must be lubricated. Screw drive is considered the most durable, though somewhat more difficult to repair if damaged; (3) limit switches, activated at each end of travel, stop the motor and toggle the state (up or down) of the controller that sets top and bottom positions of door; (4) safety stops, or door blockage sensors, detect obstructions and stop or reverse travel. Some types use a twisting motor mount that closes a set of contacts to stop the door; (5) logic controller relays or a micro-controller allows for essentially three types of door operation: momentary (in which the door operates at one touch of the button), constant or latched hold (which operates the motor only while the button is depressed), and time-latched (which opens or closes the door after a programmed time interval); (6) a remote receiver traditionally tuned to the frequency of the hand unit. A logic program here or in the controller checks the transmission to determine if the codes match. Recent units employ a “rolling code” or “security code” or some such pseudo-random code changing scheme to reduce the chance of interference or code theft. The unit is usually in a box on the wall wired to the motor; (7) remote controls, transmitters, or hand units have changed with receivers, and the FCC regulates frequency bands dedicated to various types of cordless devices that increasingly fill the airwaves; and (8) light and timer, which is usually a bimetal strip heated to operate a set of contacts. The on-time is determined by how long it takes for the strip to cool. The light is activated with the motor and is timed for three to five minutes. These last approximately 10 years but can be replaced.

Some systems include additional features, such as allowing multiple doors (including non-garage doors) to operate via a single remote, or multiple remotes for several users to operate one or more



FIGURE 10

GARAGE DOOR OPERATOR

doors. Some remotes operate lights or appliances in addition to doors. Other remotes range up to 500' with a programmable delay so the driver can enter the garage without stopping. Retrofit transmitter/receiver kits are available that operate at the flick of a headlight. Remote indicators allow residents to see whether the door is open from elsewhere in the house. Some systems come with a "vacation lock switch" to lock out all remote signals until the system is reactivated. Still others automatically push the door back down if someone tries to pry it open. A pick-resistant keyswitch or electronic lock have an extra measure of security beyond the standard door locking mechanism. Quantum doors are equipped with a locking device that automatically slides into place once the door is closed.

Metal in the vicinity of the receiver can affect remote control performance. "Short range" is becoming more prevalent, particularly as garage doors are now often steel, and insulation may have foil facing. In addition, the FCC has reduced the range of remotes. Receivers should be located away from metal. Another solution is to splice wire onto the existing antenna and have it protrude outside the garage. External antenna kits are available for some models. Windows on the door can also be helpful.

TECHNIQUES, MATERIALS, TOOLS

1. MAINTAIN EXISTING SYSTEM.

A series of accidents has resulted in investigations of automatic door safety. By 1993, laws changed such that UL garage door opener ratings varied from state to state, so systems predating 1990 often do not comply. The laws generally mandate that there be two means of reversing the door: one integral to the circuit board and one means of responding to a physical obstruction in the threshold, such as reverse edge, loop detector, or photocell. If the existing opener complies, maintenance is generally limited to lubricating the chain or screw drive with a light oil recommended by the manufacturer. To maximize the life of the opener, the door itself should function smoothly. Previous, obstructed door operation may have left components bent or broken. Disconnect the door from the opener and try to operate it manually; difficult operation means the opener is also straining.

ADVANTAGES: Low-cost alternative.

DISADVANTAGES: Professional inspection required to offset risk of non-compliant, damaged, or poorly-adjusted system.

2. REPLACE CIRCUIT BOARD AND ADD PHOTOCELL.

Since motors are essentially unchanged, most non-compliant openers can be brought up to code by installing a UL-rated circuit board in the controller that employs safety features, and adding a photocell, or eye, that will detect when an object is in the threshold. These are available in upgrade kits.

ADVANTAGES: Might be enough to bring an existing system up to code.

DISADVANTAGES: Requires professional service.

3. REPLACE REMOTE CONTROL.

If the remote control is broken, most dealers carry remotes for discontinued models; bring the old one in for a match. Home centers sell universal remote/receiver kits to be installed if the original is lost or is no



FIGURE 11

REMOTE CONTROL OPENER

longer produced, or if additional security or reliability is desired. Standard remote/receiver combinations are vulnerable to burglars recording the entry-code signal sent from the remote. Newer openers (Fig. 11) randomly alternate between 100 billion different frequencies at each door operation to prevent sound or radiowave interference, and burglars cannot break the code. These openers are recommended over the standard type, in which the user personally selects eight or more fixed DIP switch settings on the receiver and the remote. To eschew the remote, install a keyless entry pad at the garage or at another location.

ADVANTAGES: Upgrade in both security and reliability.

DISADVANTAGES: Voltage must match that of the transformer, unless a new one is included. Does not ensure state compliance.

4. REPLACE EXISTING SYSTEM WITH NEW SYSTEM.

If the existing opener is non-compliant and sufficiently damaged, or parts start failing, complete replacement may be more cost-effective than an overhaul. Modern, “low-end” openers have plastic gears that wear and eventually no longer engage. These are designed to last 10,000 to 15,000 cycles, for which homeowners can expect four to seven years of trouble-free operation. Higher end openers, however, can last 25 years or more with little maintenance, and are cost-effective considering increased life and reliability. Screw drive units have the least moving parts and are considered most reliable.

ADVANTAGES: Opportunity to tailor system to residents’ lifestyle. May be cost effective compared to retrofitting a system that does not meet code. Warranty on whole system.

DISADVANTAGES: Often the most expensive option.

FURTHER READING

“UL 325 Standard: Federal Laws for Reversing Mechanisms and Sensing Edges,” Underwriters’ Laboratories.

“Notes on the Troubleshooting and Repair of ...” *Sci.Electronics.Repair Frequently Asked Questions*, Samuel M. Goldwasser, 1999, http://plop.phys.cwru.edu/repairfaq/REPAIR/F_appfaqb.html

PRODUCT INFORMATION

The Chamberlain Group, 2301 No. Forbes Blvd., Ste. 104, Tucson AZ 85745; 800-528-9131; www.chamberlaingroup.com.

The Genie Co., 22790 Lake Park Blvd., Alliance, OH 44601; 800-654-3643; www.geniecompany.com.

Allstar Corp., P.O. Box 240, Downingtown, PA 19335; 877-441-9300; www.allstarcorp.com.

Quantum, Wayne-Dalton Corp., 3395 Addison Dr., Pensacola, FL 32514; 800-479-2000; www.wayne-dalton.com.

APPENDIX

PROFESSIONAL ASSOCIATIONS AND RESEARCH CENTERS

AMERICAN LIGHTING ASSOCIATION

P.O. Box 420288, Dallas, TX 75342-0288
800-274-4484
www.americanlightingassoc.com

AMERICAN NATIONAL STANDARDS INSTITUTE

11 West 42nd Street, 13th Floor
New York, NY 10036
212-642-4900
www.ansi.org

AMERICAN SOCIETY FOR TESTING AND MATERIALS (ASTM)

100 Barr Harbor Drive
West Conshohocken, PA 19428
610-832-9500
www.astm.org

BUILDING CONSERVATION INTERNATIONAL

1901 Walnut Street
Suite 902
Philadelphia, PA 19103
215-568-0923

BUILDING OFFICIALS & CODE ADMINISTRATORS (BOCA) INTERNATIONAL, INC.

4051 West Flossmoor Road
Country Club Hills, IL 60478-5795
708-799-2300
www.bocai.org

CONSORTIUM FOR ENERGY EFFICIENCY

303 Congress Street, Suite 600
Boston, MA 02210
617-330-9755

CONSTRUCTION SPECIFICATIONS INSTITUTE

99 Canal Center Plaza
Suite 300
Alexandria, VA 22314
800-689-2900
www.csinet.org

CONSUMER PRODUCT SAFETY COMMISSION

4330 East-West Highway
Bethesda, Maryland 20814-4408
800-638-2772
www.cpsc.gov

EDISON ELECTRIC INSTITUTE

701 Pennsylvania Ave. NW
Washington, DC 20004
202-508-5000
www.eei.org

ELECTRIC POWER RESEARCH INSTITUTE

3412 Hillview Ave.
Palo Alto, CA 94303
800-313-3774
www.epri.com

ELECTRONICS INDUSTRIES ALLIANCE

2500 Wilson Blvd.
Arlington, VA 22201-3834
703-907-7500
www.eia.org

ENERGY EFFICIENCY AND RENEWABLE ENERGY CLEARINGHOUSE (EREC)

P.O. Box 3048
Merrifield, VA 22116
800-DOE-EREC
e-mail: doe.erec@nciinc.com

GAS RESEARCH INSTITUTE

8600 W. Bryn Mawr Ave.
Chicago, IL 60631-3562
800-474-3842
www.gri.org

GREEN SEAL

1400 16th Street, NW Suite 300
Washington, DC 20036-2215
202-588-8400
www.green SEAL.org/

HOME AUTOMATION ASSOCIATION
1444 I Street NW, Suite 700
Washington DC 20005
202-712-9050
email: 75250.1274@compuserve.com

HOME ENERGY RATING SYSTEMS COUNCIL
1331 H St., NW, Suite 1000
Washington, DC 20005
202-638-3700 (phone)
202-393-5043 (fax)
www.hers-council.org

ILLUMINATING ENGINEERING SOCIETY (IES)
120 Wall Street, 17th Floor
New York, NY 10005-4001
212-248-5000
www.iesna.org

INSTITUTE OF ELECTRICAL AND
ELECTRONICS ENGINEERS
IEEE Service Center
445 Hoes Lane, P.O. Box 1331
Piscataway, NJ 08855-1331
800-678-4333
www.ieee.org

INTERNATIONAL CODE COUNCIL
5203 Leesburg Pike, Suite 708
Falls Church, VA 22041
703-931-4533
www.intlcode.org

THE INTERNATIONAL CONFERENCE OF
BUILDING OFFICIALS (ICBO)
5360 Workman Mill Drive
Whittier, CA 90601-2298
310-699-0541
www.icbo.org

INTERNATIONAL REMODELING
CONTRACTORS ASSOCIATION
1 Regency Drive
Bloomfield, CT 06002
800-937-4722

INTERNATIONAL STANDARDS ORGANIZATION
1, rue de Varembe
Case postale 56
CH-1211 Gene've 20, Switzerland
41-22-749-01-11
<http://iso.ch/welcome.html>

LAWRENCE BERKELEY NATIONAL
LABORATORY
Building Technologies Program
Energy and Environment Division
Lawrence Berkeley Laboratory, Berkeley, CA
94721
510-486-6844
www.eandelbl.gov/BTP/BTP.html

LIGHTING RESEARCH CENTER
School of Architecture
Rensselaer Polytechnic Institute
Green Building 115
Troy, NY 12180
518-276-8716
www.lrc.rpi.edu/

LIGHTNING PROTECTION INSTITUTE
3335 N. Arlington Heights Road
Suite E
Arlington Heights, IL 60004
800-488-6864
www.lightning.org

NAHB REMODELERS COUNCIL
1201 15th Street, NW
Washington, DC 20005
202-822-0212
www.nahb.com/remodelc.html

NATIONAL ALARM ASSOCIATION OF AMERICA
P.O. Box 3409
Dayton, OH 45401
800-283-6285
www.naaa.org

NATIONAL ASSOCIATION OF PLUMBING,
HEATING AND COOLING CONTRACTORS
180 S. Washington St.
P.O. Box 6808
Falls Church, VA 22040
703-237-8100
www.naphcc.org

NATIONAL ASSOCIATION OF THE
REMODELING INDUSTRY
4900 Seminary Road, Suite 320
Arlington, VA 22311
703-575-1100
www.nari.org

NATIONAL BURGLAR AND FIRE ALARM
ASSOCIATION
7101 Wisconsin Avenue, Suite 901
Bethesda, MD 20814
301-907-3202
www.alarm.org

NATIONAL ELECTRICAL CONTRACTORS
ASSOCIATION
3 Bethesda Metro Center, Suite 1100
Bethesda, MD 20814
301-657-3110
www.necanet.org

NATIONAL ELECTRICAL MANUFACTURERS
ASSOCIATION (NEMA)
1300 North 17th Street
Suite 1847
Rosslyn, VA 22209
703-841-3200
www.nema.org

NATIONAL FIRE PROTECTION ASSOCIATION
1 Batterymarch Park
Quincy, MA 02269-9101
800-344-3555

NATIONAL RENEWABLE ENERGY LABORATORY
1617 Cole Boulevard
Golden, CO 80401
303-275-3000
www.nrel.gov

NATIONAL TECHNICAL INFORMATION SERVICE
US Department of Commerce
www.fedworld.gov/ntis/ntishome.html

RADIANT PANEL ASSOCIATION
P.O. Box 327
Hyrum, UT 84319
801-245-0128

SOLAR ENERGY INDUSTRIES ASSOCIATION
(SEIA)
122 C Street NW, 4th Floor
Washington DC 20001
202-383-2600 <http://solstice.crest.org>

SOUTHFACE ENERGY INSTITUTE
241 Pine Street
Atlanta, GA 30308
404-872-3549
<http://southface.org>

SUSTAINABLE BUILDINGS INDUSTRY COUNCIL
1331 H Street, NW, Suite 1000
Washington, DC 20005
202-628-7400
www.sbicouncil.org

TELECOMMUNICATIONS INDUSTRY
ASSOCIATION
2500 Wilson Blvd., Suite 300
Arlington, VA 22201
703-907-7700
www.tiaonline.org

UNDERWRITERS LABORATORIES, INC.
333 Pfingsten Road
Northbrook, IL 60062-2096
847-272-8800
www.ul.com

UNITED LIGHTNING PROTECTION
ASSOCIATION (ULPA)
P.O. Box 22683
Lake Buena Vista, FL 32830
800-668-ULPA
www.ulpa.org

U.S. CONSUMER PRODUCT SAFETY
COMMISSION
Washington, DC 20207
800-638-2772
www.cpsc.gov

U.S. DEPARTMENT OF ENERGY'S
ENERGY EFFICIENCY AND RENEWABLE
ENERGY NETWORK
www.eren.doe.gov

U.S. DEPARTMENT OF ENERGY'S ENERGY
EFFICIENCY AND RENEWABLE ENERGY
CLEARINGHOUSE
P.O. Box 3048
Merrifield, VA 22116
800-363-3732
www.eren.doe.gov/erec/

U.S. DEPARTMENT OF HOUSING
AND URBAN DEVELOPMENT
HUD User
P.O. Box 6091
Rockville, MD 20849
www.huduser.org
800-245-2691

U.S. GOVERNMENT FEDERAL INFORMATION
NETWORK
www.fedworld.gov/

THE REHAB GUIDE

VOLUME ONE: FOUNDATIONS

VOLUME TWO: EXTERIOR WALLS

VOLUME THREE: ROOFS

VOLUME FOUR: WINDOWS AND DOORS

VOLUME FIVE: PARTITIONS, CEILINGS, FLOORS AND STAIRS

VOLUME SIX: KITCHENS & BATHS

VOLUME SEVEN: ELECTRICAL/ELECTRONICS

VOLUME EIGHT: HVAC/PLUMBING

VOLUME NINE: SITE WORK

U.S. Department of Housing and Urban Development
Washington, DC 20410-6000

Official Business
Penalty for Private Use, \$300

April 2000
HUD-DU100C000005956

