

VOL 9



THE REHAB GUIDE

10 FEET
SLOPES GREATER
THAN 25%

10' SWIMMING POOLS

10' DRIVEWAYS

100' W

10' PROPERTY LINE

50' WATER
SURFACE

20' ON OTHER
LOTS SYSTEMS

SITE WORK



PATH (Partnership for Advancing Technology in Housing) is a new private/public effort to develop, demonstrate, and gain widespread market acceptance for the “Next Generation” of American housing. Through the use of new or innovative technologies the goal of PATH is to improve the quality, durability, environmental efficiency, and affordability of tomorrow’s homes.

Initiated at the request of the White House, PATH is managed and supported by the Department of Housing and Urban Development (HUD). In addition, all Federal Agencies that engage in housing research and technology development are PATH Partners, including the Departments of Energy and Commerce, as well as the Environmental Protection Agency (EPA) and the Federal Emergency Management Agency (FEMA). State and local governments and other participants from the public sector are also partners in PATH. Product manufacturers, home builders, insurance companies, and lenders represent private industry in the PATH partnership.

To learn more about PATH, please contact:

PATH
Suite B 133
451 7th Street SW
Washington, DC 20410
202-708-4250 (fax)
e-mail: pathnet@pathnet.org
website: www.pathnet.org

DISCLAIMER

The statements and conclusions contained in this report are those of Steven Winter Associates, Inc. and do not necessarily reflect the views of the Department of Housing and Urban Development. Steven Winter Associates, Inc. has made every effort to verify the accuracy and appropriateness of the report’s content. However, no guarantee of the accuracy or completeness of the information or acceptability for compliance with any industry standard or mandatory requirement of any code, law, or regulation is either offered or implied. The products listed in the report are included only as examples of some available products. No endorsement, recommendation, or evaluation of these products or their use is given or implied.

SITE WORK

VOLUME 9 OF THE REHAB GUIDE

TABLE OF CONTENTS

FOREWORD **3**

1. INTRODUCTION **4**

2. WOOD DECKS/PORCHES AND FENCES **6**

3. PAVED DRIVEWAYS, WALKS, PATIOS & MASONRY WALLS **23**

4. UNDERGROUND CONSTRUCTION **35**

5. LANDSCAPING **44**

APPENDIX: PROFESSIONAL ASSOCIATIONS & RESEARCH CENTERS **51**

Prepared for:
U.S. Department of Housing
and Urban Development
Office of Policy Development
and Research

Prepared by:
Steven Winter Associates, Inc.
Building Systems Consultants
Norwalk, CT

Contract DUIOOC000005956
August 2000

CREDITS

STEVEN WINTER ASSOCIATES, INC. STAFF MEMBERS
WHO WERE INSTRUMENTAL IN THE DEVELOPMENT AND
PRODUCTION OF THIS GUIDEBOOK INCLUDE:

Steven Winter
Principal-in-charge

Michael J. Crosbie, Ph.D., RA
Project manager and editor-in-chief

Jeff Goldberg
Illustrator

Debra Lombard, Jeff Goldberg, Jeff Bellows
Project team members

U.S. DEPARTMENT OF HOUSING AND URBAN DEVELOPMENT
OFFICE OF POLICY DEVELOPMENT AND RESEARCH, AFFORDABLE
HOUSING RESEARCH AND TECHNOLOGY DIVISION

David Engel
Director

Nelson Carbonell
Senior architect

GUIDEBOOK DESIGN

Andrew P. Kner
Art director

Michele L. Trombley
Assistant art director

Elizabeth Rosen
Symbols

FOREWORD

President Clinton recognizes that research and technological innovation are crucial if America is to meet its affordable housing needs. In 1998, the President introduced a major new initiative: The Partnership for Advancing Technology in Housing (PATH). This initiative brings together leaders from the homebuilding, product manufacturing, insurance, and financial industries, as well as representatives from federal agencies, to spur housing design and construction innovations.

Thanks to the development of new machinery and materials and the creation of new technologies and techniques, the construction industry has made great progress. But a breakthrough material, a labor-saving tool, or a cost-cutting technique is only valuable if it is widely adopted, which means the construction industry must first become aware of these new developments.

The Department of Housing and Urban Development can help. We have commissioned a set of guidebooks that will present state-of-the-art techniques, materials, and technologies for housing rehabilitation. This volume, *Site Work*, is the last of nine guidebooks—known collectively as *The Rehab Guide*.

We are presenting these guidebooks because, like research and technological innovation, housing rehabilitation is an essential component of America's commitment to provide affordable housing. I am pleased to present this important publication in the hope that it will become a valuable resource that leads to affordable, high quality rehabilitation, and thus to better housing for all Americans.

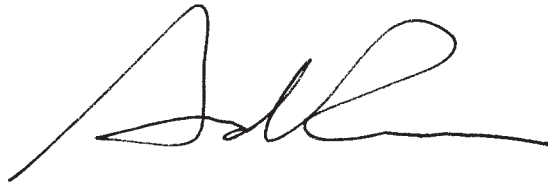
A handwritten signature in black ink, appearing to read 'A. Cuomo', with a long horizontal flourish extending to the right.

Andrew Cuomo, Secretary
U.S. Department of Housing and Urban Development

INTRODUCTION

This series of guidebooks has been produced by the U.S. Department of Housing and Urban Development to keep the design and construction industry abreast of innovations and state-of-the-art practices in home rehabilitation. As is too often the case, innovative techniques, materials, technologies, and products are slow to make their way into accepted practice. It is evident that such innovations will not advance unless the industry is made aware of them and they are tested. *The Rehab Guide* is intended to accelerate this process by informing builders, architects, engineers, and other housing rehabilitation professionals about such innovations and state-of-the-art practices.

The Rehab Guide was also prompted by the lack of a comprehensive publication to make the design and construction industry aware of innovative and cost-saving developments in housing rehabilitation. Professional trade magazines, conferences, and trade shows offer some dissemination of this information, but they are rarely focused exclusively on housing rehabilitation, as this series is, nor are they comprehensive.

FOCUS OF THE REHAB GUIDE

The focus of this series is on housing rehabilitation, which is different than home improvement. Rehabilitate means “to restore to good condition,” not necessarily to improve to a state that is significantly different than the original. This is a fine line, but it distinguishes this series from “home improvement” books written for the amateur. *The Rehab Guide* focuses on building technology, materials, components, and techniques rather than “projects” such as adding a new room, converting a garage into a den, or finishing an attic. Nor is *The Rehab Guide* intended to be a “diagnostic” tool; a number of such books are already available to the industry.

The content for this guidebook, *Site Work*, has been gathered from professionals in the housing rehabilitation field; manufacturers and suppliers of innovative technologies, materials, components, tools, and equipment; trade shows, conferences, reports, and publications considering such issues; trade organizations; and building research centers.

A NOTE ON SOURCES

A variety of excellent resources exists for information on site rehab work. *The Builder's Graywater Guide* is a good source on managing waste water on site; *Energy Efficient and Environmental Landscaping* is a guide to using the landscape for energy efficiency, and *Landscaping with Native Trees* is helpful in choosing the right vegetation for the various climatic regions of the US. Monthly publications of interest include *E-Build*, *Environmental Building News*, *Fine Homebuilding*, *Journal of Light Construction*, *Old-House Journal*, *This Old House*, and *Traditional Builder*.

Helpful information is also accessible via the Internet. Most equipment manufacturers and monthly magazines have websites where specific product information and past articles can be retrieved.

LEAD PAINT HAZARD

The hazard of lead paint in houses constructed before the 1980s is not discussed in the *The Rehab Guide* because there is extensive material available from HUD, the Environmental Protection Agency (EPA), and other sources. However, if you are a non-profit or rehab contractor rehabilitating pre-1978 housing for sale or rent, or if you are a homeowner rehabilitating a home for your own use, you are strongly urged to have the home tested for lead paint. This is especially critical if the home will be occupied by young children. Very small amounts of lead in paint or dust can poison children if swallowed or inhaled, causing damage to the brain and other organs, resulting in health problems and reduced intelligence. If lead paint is found, it is critical that all rehabilitation be done very carefully to reduce the possibility of lead poison-

ing to you or your workers. Proper work practices will minimize the risk of spreading lead contamination and increasing occupant exposure.

One of the best and most recent sources on this subject is the HUD publication, “Lead Paint Safety: a Field Guide for Painting, Home Maintenance, and Renovation Work.” Another good publication is the EPA brochure, “Reducing Lead Hazards When Remodeling Your Home.” Both can be obtained by calling the National Lead Information Center at 800-424-LEAD or by downloading from the web site of the HUD Office of Lead Hazard Control, www.hud.gov/lea. A very comprehensive source is the HUD publication, “Guidelines for the Evaluation and Control of Lead-Based Paint Hazards in Housing,” which gives guidance on controlling lead hazards, lead paint and rehab work, risk assessment, monitoring, inspections, resident and work site preparation, worker protection, and routine building maintenance. This publication is available through HUD-User; you can also download a copy of this document from the HUD web site at: www.hud.gov:80/lea/learules.html.

HUD has new regulations on lead-based paint hazards in federally owned housing and housing receiving federal assistance. If you will be using HUD funds for rehabilitation through grants, insurance, or other types of assistance, then there are protective procedures that must be followed. The Occupational Safety and Health Administration website at www.osha.gov has information on worker protection requirements. In addition, many states and localities have their own rules regarding lead-based paint, which should be followed when undertaking rehabilitation.

HOW THE GUIDE IS ORGANIZED

Nine volumes make up *The Rehab Guide* in its entirety, and they are listed on the back cover of this volume. Each one is devoted to distinct elements of the house, and within each volume is a range of issues that are common to that element of home rehabilitation work. This volume covers topics from repair of existing exterior structures such as fences, porches, and decks, to fixing or replacement of septic systems and water supply lines, and the repair of paved surfaces such as driveways and walks in a variety of materials. Each volume addresses a wide range of techniques, materials, and tools, with recommendations based on regional differences around the country. Throughout *The Rehab Guide*, special attention is given to issues related to energy efficiency, accessible design, and sustainability.

The Rehab Guide is written and presented in a format intended for easy use. The spiral bound volumes open flat so that they can be easily photocopied, and they can be assembled and stored in a single three-ring binder. Within each volume, drawings, photos, and other graphic materials supplement written descriptions of a broad range of items: state-of-the-art and innovative building technology, products, materials, components, construction and management techniques, tools, equipment, software—virtually any and all items that make housing rehabilitation more efficient in terms of cost and time. While the content focuses on present technologies and techniques that are currently part of the house-building industry, *The Rehab Guide* also includes information on materials, products, and procedures from other construction sectors (such as commercial, industrial, institutional) that are relevant to housing rehabilitation.

The information is organized in different sections according to rehab subjects, and under headings that make this book easy to understand. “Essential Knowledge” gives the reader a basic overview of the important issues related to the section heading. Next, “Techniques, Materials, Tools” presents state-of-the-art and innovative approaches to accomplishing the work. Each entry is explained in detail, including its advantages and disadvantages. This makes it easy for readers to compare approaches and choose the one that is most applicable to their particular project. By design, the “Techniques, Materials, Tools” section is an overview, not a detailed description of implementation. “Further Reading” lists the valuable resources relevant to the subject that readers can go to for more detailed information. Finally, “Product Information” provides names and addresses of manufacturers of products, materials, systems, and components mentioned in the text so that more information can be obtained. By virtue of their being listed here, such products are not necessarily being recommended; their existence and availability are being brought to the reader’s attention. New products should be carefully evaluated in the field as to their performance. The product lists are not necessarily comprehensive, and we encourage readers to bring new materials and products to our attention to be included in later editions of *The Rehab Guide*.

2

WOOD DECKS/ PORCHES AND FENCES

2.1

DECK/PORCH STRUCTURE

ESSENTIAL KNOWLEDGE

The structure of a wood deck or porch is subject to moisture and rot conditions because of its exposure to the elements. Water absorbed by the wood structure increases the material's moisture content, causing rot and decay, compromising the material's strength. Among the indications of wood rot are cracked or sagging floorboards; peeling paint (which provides a moisture barrier); and discolored or soft areas of the wood that should be cut and removed to halt rot spread. Such moisture and rot problems can easily spread to the structure of the house itself where it comes into contact with decks and porches, if remedial action is not taken. The best prevention for rot in wood is to use treated wood and to seal it periodically. Rehabilitating the structure of a wood deck or porch may require removing the rotted portions of the structure and replacing them. Another option is to remove the rotted material and fill with an epoxy. If the deckboards are damaged from weathering, you can sand the surface to make it smooth. Countersink the deck nails or screws below the surface with a nail set. Using a belt sander, sand in the direction of the grain and keep the sander moving to avoid gouges in the deck boards.

TECHNIQUES, MATERIALS, TOOLS

1. REPAIR MOISTURE-DAMAGED POSTS OR COLUMNS.

The most efficient and effective correction to rotting wood posts and columns is to remove the damaged material and replace it with new material. If you are removing deck posts or columns, support the deck with a jack post, house jack, or crossed timbers under the rim joist. Place a board between the ground and the jack as well as between the jack and the rim joist to prevent damaging the joist. To support the roof for removing porch posts or columns, use ground-to-eave bracing of doubled 2x4s or 2x6s. Nail a cleated top plate to the roof framing and nail bracing to top plate in front of cleat. Nail a cleat to the bottom plate and nail the bracing behind the cleat. Stakes behind the bottom plate prevent the bracing from sliding, keeping bracing as vertical as possible.

Cut a lap joint at least 18" long in the existing post, above the damaged area. To make the cross-cut, set a circular saw to exactly half the depth of the post. Then rip from both sides down the center. Use a chisel to clean up the portion of the joint where the circular saw blade does not reach. Install three staggered bolts through the posts to hold them together, with the top bolt 3" from the old post and the bolts spaced 6" apart. Make sure that the new member has a preservative treatment retention greater than the other deck members not coming into contact with the ground.

ADVANTAGES: Saves material and time by replacing only part of a post.

DISADVANTAGES: Conditions that cause rot should be corrected before repair work is done.

2. REPAIR MOISTURE-DAMAGED JOISTS.

If only the top of a joist needs repair, leave the joist in place. Apply a thick coat of sealer-preserved to the damaged joist, let dry, then apply a second coat. Treat all sides of the new partner reinforcing joist (2x4 or 2x6 of pressure-treated lumber) with clear sealer-preserved, and let dry. Align the top edges of the partner and old joist. Partner the new piece by nailing it to the damaged joist tightly with 16d galvanized nails or deck screws (Fig. 1). Treat the ends of the new joist with sealer-preserved where it was cut.

Wood grades are important for structural members. Quality grades run in descending order. Choose grade No. 1 for railings and benches, and grade No. 2 or BTR for decking. Also check the grade stamp for the letters KDAT (kiln-dried after treatment) which is more dimensionally stable than air-dried wood. Use hot-dipped galvanized, aluminum or stainless-steel (ring-shanked) nails, screws, and other fasteners.

ADVANTAGES: Saves materials and time by replacing only portion of joist.

DISADVANTAGES: May be difficult to repair if access under deck is limited. In such cases, the deck boards can be removed to access the joists, then reinstalled after repair. If all of the rot in a joist has not been cut out and removed, the rot can easily spread to the rest of the joist.

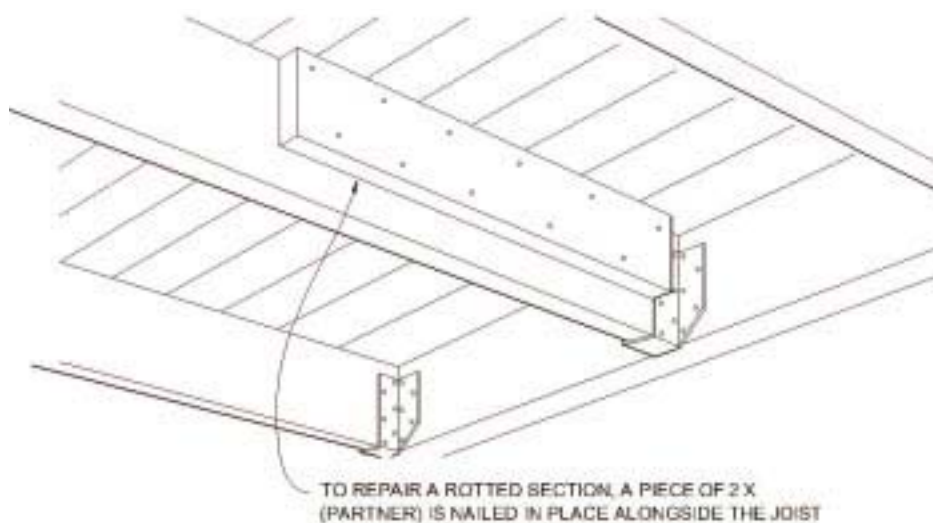

FIGURE 1

REINFORCING JOIST

3. REPAIR ROTTED LEDGER BOARDS.

The ledger board is the joist attached to the house. Very often, the ledger will start to rot from water trapped between it and the house, unless it is properly flashed (Fig. 2). This rot then can spread to the ends of the joists that rest on the rotted ledger board. You will need to replace the ledger board and trim the rotten ends off the joists (Fig. 3).

Remove deck boards over the area of rotted joists and ledger. Run a 2x6 on edge under the joists and support it with 4x4s. Remove the rotted ledger, trim all of the joists the same length with a reciprocating or circular saw. Coat the ends with wood preservative. Cut two or more new ledger boards the same size as the old material from pressure-treated lumber. Sandwich the ledger boards together and bolt them to the house, using the old ledger board for the bolt hole spacing. Seal around the ledger with caulking compound. If the house has siding, install flashing under the siding and over the ledger (Fig. 2). Attach joists to sandwiched ledger with joist hangers and replace deckboards.

If you cannot remove the ledger board, use an epoxy wood hardener or filler. To repair a partially rotted ledger board, drill several 1/8" holes throughout the area and inject the mixed liquid epoxy hardener. At any damaged corners, chisel away to the good wood and slightly overfill with liquid epoxy wood filler. After it is dry, sand and shape the patch.

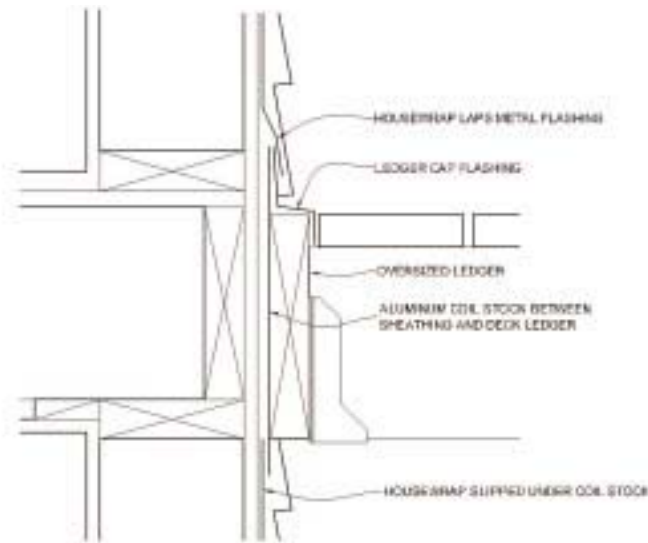

FIGURE 2 LEDGER FLASHING

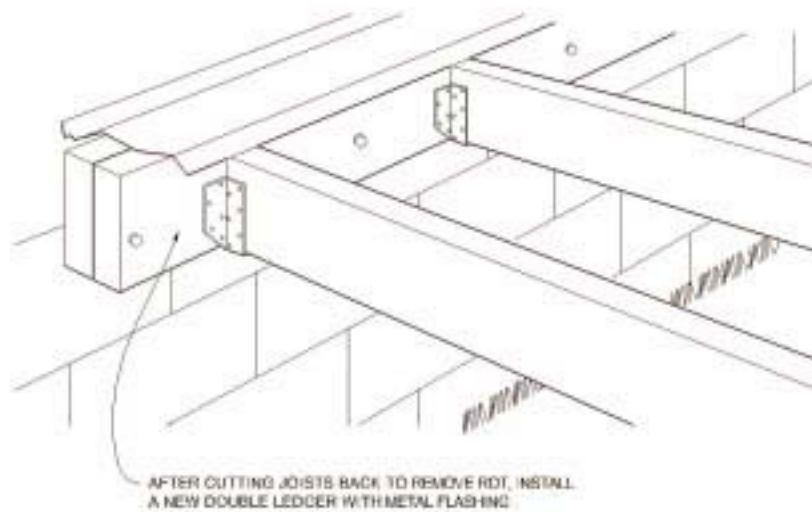

FIGURE 3 REPLACEMENT LEDGER BOARDS

ADVANTAGES: Saves materials and time by replacing only portion of deck.

DISADVANTAGES: Ledger board may be difficult to repair if access under deck is limited.

4. STABILIZE ROTTING MATERIAL WITH EPOXY.

An alternative to replacing entire structural members or portions of members is to use epoxy restoration products. If the rot is not extensive, products such as LiquidWood or WoodEpoxy can be used to restore the member's structural integrity. Such repairs can be achieved by two different products: consolidants for wood that is intact; and a putty-like filler material for areas that are missing or require removal because they are beyond repair. Epoxy consolidants penetrate and bind with the wood fibers while preventing further decay. They are either poured or brushed on the surface in liquid form, and bond with the wood fibers to create a filler with greater strength than wood that is water resistant. The material cures in a few minutes to a few hours (depending on the extent of the repair). Consolidants may be used as a primer for the application of epoxy putty filler.

ADVANTAGES: Epoxy fillers are preferable to solvent-based wood fillers, which may shrink as they cure or become loose as materials expand and contract at different rates. Can be worked as wood; a low-cost solution.

DISADVANTAGES: The repair of damaged structural members will not address the cause or progressive deterioration of adjacent materials.

FURTHER READING

Building & Designing Decks, Scott Schuttner, Taunton Press, Newtown, CT, 1993, 154 pp.

“Epoxy Repairs for Exterior Wood,” John Leeke, *Practical Restoration Reports*, Historic Home Works, Portland, ME 04103; 207-773-2306; www.historichomeworks.com/HHW/reports/reports.htm, 10 pp.

“Exterior Wood Columns,” John Leeke, *Practical Restoration Reports, Historic Home Works*, Portland, ME 04103; 207-773-2306; www.historichomeworks.com/HHW/reports/reports.htm, 17 pp.

“Exterior Woodwork Details,” John Leeke, *Practical Restoration Reports*, Historic Home Works, Portland, ME 04103; 207-773-2306; www.historichomeworks.com/HHW/reports/reports.htm, 16 pp.

Ortha's Home Improvement Encyclopedia (Revised), Robert J. Beckstrom and John Reed, The Solaris Group, San Ramon, CA, 1994. 511 pp.

PRODUCT INFORMATION

ConServ Epoxies/Housecraft Associates, 7 Goodale Road, Newton, NJ 07860; 973-579-1112; www.conservepoxy.com.

DeckWorks Construction, 1511 Avondale Dr., Norman, OK 73069; 888-297-1455, 405-364-3002, 405-360-6297 (fax); www.deckworks.com.

Gougeon Bros. Inc., P.O. Box 908, Bay City, MI, 48707; 517-684-7286.

Life Industries Corp., 2081 Bridgeview Drive, PO Box 71789, Charleston, SC 29415; 843-566-1225; www.lifeindustries.com.

LiquidWood (wood consolidant) and WoodEpoxy (adhesive wood-replacement paste), solvent-free liquid epoxy systems by Abatron Inc., 5501 95th Avenue, Kenosha, WI, 53144; 800-445-1754; http://www.abatron.com/products_overview.htm.

2.2

REPAIR/REPLACE WOOD DECKING MATERIALS

ESSENTIAL KNOWLEDGE

Wood decking that has discolored because of mildew can be cleaned and restored. Untreated or unsealed decking exposed to the elements can split, cup, splinter, or check. The best solution is to replace these decking materials with new materials, either matching the original materials or with new decking materials that have greater resistance to degradation. Alternative materials that are rot-resistant require very little maintenance and offer a longer life cycle. For example, new types of plastic lumber can eliminate the problems with wood rot and may be more cost-effective over the life of a structure, even though they typically cost more than treated wood. An array of new decking materials lasts longer and reduces maintenance. Other choices include exotic hardwoods that are naturally insect-resistant. In addition, there is a variety of non-wood products, such as engineered vinyl systems and plastic-wood composites, all available in different shapes, widths, grades, and treatments.

TECHNIQUES, MATERIALS, TOOLS

1. CLEAN MILDEW-STAINED WOOD DECKING.

You can remove stains and weathering with a deck brightener (a wood bleach), trisodium phosphate (TSP), or restain the deck. Afterwards, apply a wood sealer to protect the finish. It may be easier to bleach out the individual stains than to stain the entire deck. Make sure that the wood deck brightener that you use is compatible with your type of wood. Test a small, inconspicuous portion of the deck before applying to a large area.

ADVANTAGES: A relatively easy, low-cost process.

DISADVANTAGES: Can result in bleached “hot spots” if not carefully applied.

2. REPAIR OR REPLACE EXISTING DECKING.

Splintered deck boards can be sanded or turned over so that the underside is used as the new surface. If sanding, counter-sink or remove the screws prior to sanding. Should a deck board need to be removed, get underneath the deck and hammer up on the boards to loosen them, or use a pry bar. If access from below is not possible, bore holes into the good wood adjacent the damaged area. Connect these holes with saw cuts, using a keyhole saw or electric jigsaw, avoiding the joists below, and remove the decking. Cut out any sections of bad decking up to the joist. Treat any remaining rot on the existing joist with a fungicide. Then install a short piece of 2x4 (support cleat) even with the top edge of the joist to support the new decking (Fig. 4). Cut the new decking to size and nail it into place, using two nails at each joint for 2x4s and 3 nails for 2x6s. To keep the 2x4 cleat flush against the underside of the new decking, if access from below is possible nail the cleat loosely to the joist and, after decking is installed, push cleat tight against the deck underside and then nail into place. If all the decking must be replaced due to moisture damage, ensure that the new decking slopes away from the house so that water will drain.

ADVANTAGES: Saves material and time by replacing only deck boards that are rotted.

DISADVANTAGES: Rot spreads throughout the wood from inside out; a cursory inspection may not reveal areas of rot that need removal. Conditions contributing to rot should be corrected before replacing material.

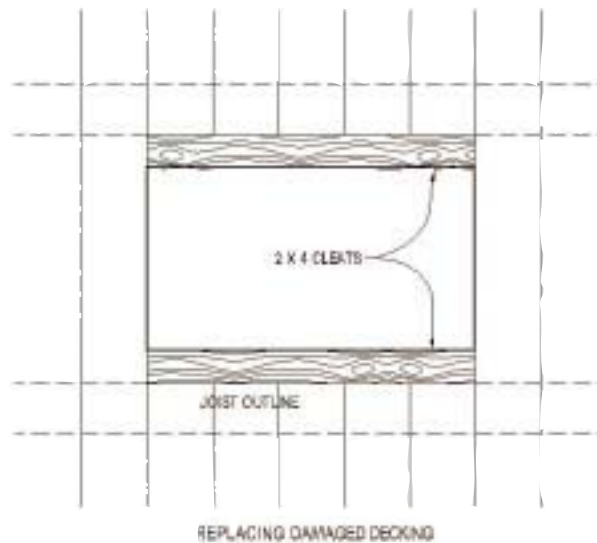

FIGURE 4

SUPPORT CLEATS FOR NEW DECKING

3. REPLACE WITH CERTIFIED SUSTAINABLY HARVESTED WOOD.

Typical lumber harvesting puts stress on the ecosystem and animal habitats of the forest and nearby streams used to transport the lumber. The Forest Stewardship Council has established environmental standards for forestry operations, which require a logging company to avoid the over-harvesting of timber,

minimize waste of felled trees, protect threatened and endangered species, and control erosion. In addition, there are two other lumber certification groups: Scientific Certification Systems and the Rainforest Alliance's SmartWood Program. FSC has accredited both groups to certify that wood has met FSC standards. To date, SmartWood and SCS have certified more than 40 U.S. forestry operations, covering nearly 5 million acres. Consult with forest certification organizations for certified lumber suppliers and Co-Op America, which also maintains a database.

ADVANTAGES: Use of sustainably harvested wood benefits the local ecosystem.

DISADVANTAGES: Sustainably harvested lumber may not be readily available. Contact national suppliers of certified wood for their nearest retail outlets (some may even supply directly).

4. REPLACE WITH REDWOOD AND CEDAR.

Cedar deck boards are easily available, while redwood may require several days for special orders. For redwood, use a kiln-dried deck heart or A deck common grades. Clear heart, clear, B heart, and B grade redwood are economical choices. For cedar, clear all-heart is the premium choice. Good, lower-cost alternatives include appearance grade and, for dry areas, No. 1 select tight knot (STK). Use hot-dipped galvanized aluminum or ring-shanked stainless-steel nails, screws, and other fasteners.

ADVANTAGES: Redwood and cedar heartwood has glowing color, straight grains, and natural resistance to rot and insects. Boards are easy to cut and can be left untreated to weather naturally. Service life is easily more than 20 years.

DISADVANTAGES: Both woods are costly. Redwood sapwood is the newer wood closer to the bark; it may rot when exposed to moisture for sustained periods of time. Cedar sapwood breaks down quickly in moist conditions.

5. REPLACE WITH TROPICAL HARDWOODS.

Among tropical hardwoods are Ipe, Ironwood, Cambara, and Pau Lope. Ipe is a durable, teak-like tropical hardwood widely available sold as Ironwood. Ipe is twice as strong as oak and is more durable than redwood and cedar. It has a service life of 40 years or more, and is resistant to insects and decay. Ironwood is backed by a 25-year transferable warranty. Another tropical hardwood option is Cambara, which is not as durable, hard, or stable as Ipe, and requires more maintenance. However, Cambara is also knot-free and less costly than Ipe. Cambara is similar to cedar or Meranti in durability and requires sealing. Pau Lope is a long-lasting material that requires virtually no maintenance. It is five times harder than pine, cedar, and redwood; resists splitting and splintering; and is free of toxic preservatives and arsenic. Pau Lope has the highest rating from the U.S. Department of Agriculture for insect- and decay-resistance; is priced comparable to cedar; and requires almost no maintenance. The material comes with a 20-year limited warranty.

ADVANTAGES: All grades are virtually knot-free, and tight grain patterns make tropical hardwoods impervious to water.

DISADVANTAGES: These materials are often costly. Because of their hardness, they require pre-drilling for fasteners. Ipe is available in most standard dimensions for decking but delivery can take up to three weeks.

6. REPLACE WITH PLASTIC-WOOD COMPOSITES.

Virtually indestructible, plastic-wood composites blend 30% to 50% recycled plastic with wood fibers for skid resistance and stainability. Composite lumber is low-maintenance, and resists rot, insects, and UV rays. It is also splinter-free and therefore easy to work with. Composite lumber weathers to a light gray and can be painted or stained, although protective sealers are not required. Galvanized fasteners are recommended. Both ChoiceDek and DuraWood deck-and-rail systems are formed to allow running wires within posts or deck boards. Nexwood is a structural recycled plastic/rice hull composite decking material. Trex, TimberTech and DuraWood EX come with 10-year warranties, while ChoiceDek and DuraWood PE are backed for 20 years.

ADVANTAGES: Materials are nearly maintenance free and contain nontoxic elements.

DISADVANTAGES: Contractors have to become familiar with different load characteristics and fastening techniques. Because composites lack the strength of solid wood, they require more material for framing.

Some building inspectors may be unfamiliar with the materials. Some composite lumber has a plastic appearance, and some colors fade over time. During construction, sawdust and shavings should be collected in a drop cloth because they are not biodegradable. Not all composite lumber can span 16" or 24" joist spacing. Therefore, closer joist layout may be needed, which increases costs. Some building codes may not allow composite lumber; check local code requirements.

7. REPLACE WITH VINYL DECK SYSTEMS.

Vinyl deck systems typically include deck boards, rails, spindles and fascia. Three major manufacturers of vinyl deck systems are Kroy, DreamDeck, and EZ Deck, which offer a variety of plank widths and limited, lifetime warranties. These materials cut and work much like wood, but are lighter. Vinyl decking is framed conventionally, but special clips are screwed into stringers and boards are hammered into the clips. Skid-resistant planks provide an added measure of safety. Vinyl decks weather a bit during the first few months after installation. To reduce fading most high-end vinyl contains more ultra-violet (UV) inhibitors than even high-end siding. Color-fast, no-fade materials available from manufacturers such as EZ Deck hold up better under exposure from UV light. Planks can be cut to length with a circular saw; plank ends are covered with vinyl caps. Proprietary strip systems are screwed to joists with galvanized or stainless-steel screws, then planks snap into place.

ADVANTAGES: Low-maintenance materials that require no sealers or finishes and are free of splinters and cracks. Planks have good spanning ability and resist UV rays if treated at the factory. Fasteners can be completely hidden once planks are installed.

DISADVANTAGES: Relatively costly and must often be ordered through distributors. Vinyl can fade and become brittle with age unless specially treated at the factory; all vinyl eventually loses its gloss. Sawdust from vinyl decking is not biodegradable, so it must be collected.

FURTHER READING

Wood Decks: Materials, Construction, and Finishing, Kent McDonald and Robert Falk, Madison, WI: Forest Products Society, 1994, 94pp.

"Recycled Plastic Lumber," *Environmental Building News*, 2 (4), 1993, pp. 1-17; *Environmental Building News*, Brattleboro, VT 05301; 802-257-7300; www.ebuild.com.

WoodWise Consumer Guide, Co-op America, Washington, DC 20006; 202-872-5307; www.WoodWise.org.

PRODUCT INFORMATION

Cabot Wood Care products (wood cleaner, water proofing, stains), Newburyport, MA 01950; 800-US-STAIN; www.cabotstain.com.

Certified Forest Products Council, Beaverton, OR 97007; 503-590-6600; www.certifiedwood.org.

Certified sustainable harvested pressure-treated lumber source list, SmartWood Program of Rainforest Alliance, Richmond, VT 05477; 802-434-5491; www.smartwood.org.

ChoiceDek, Advanced Environmental Recycling Technologies (AERT) Junction, TX 76849; 800-951-5117; www.choicedek.com.

Co-op America's National Green Pages, 800-58-GREEN; www.coopamerica.org.

DeckWorks Construction, 1511 Avondale Dr., Norman, OK 73069; 888-297-1455, 405-364-3002, 405-360-6297 (fax); www.deckworks.com.

EnviroWood (100% post consumer and post industrial scrap plastic), EnviroWood Auburn, AL 36832; 888-357-8392; www.envirowood.com.

Forest Stewardship Council (FSC), Waterbury, VT 05676; 802-244-6257; www.fscus.org.

Greenheart-Durawoods Inc., Bayville, NJ 08721; 800-783-7220; www.paulope.com.

Greenseal, Washington DC 20036; 202-872-6400; www.greenseal.org.

Heritage Vinyl Products' Teck Deck (vinyl decking system has planks that snap onto boards with screws which are hidden by the planks), Macon, MS 39341; 800-473-3623; www.heritagevinyl.com.

Hickson Inc., Smyrna, GA 30080; 770-801-6600; www.hickson.com.

Ipe and Cambara wood, Timber Holdings Ltd., Milwaukee, WI 53209; 414-445-8989; www.ironwoods.com.

Kodiak Inc., Memphis, TN 38109; 800-556-3425; www.kodiakwood.com.

Kroy Decks, York, NE 68467; 800/933-5769; www.kroybp.com.

MAXiTUF (100% recycled plastic lumber), Resco Plastics, Inc., Coos Bay, OR 97402; 541-269-5485; www.rescoplastics.com.

Nexwood (structural recycled plastic, rice hulls composite decking), Composite Technology Resources, Ltd., Lasalle, Quebec; 888-763-9966 Canada; e-mail: nexwood@cam.org.

Pau Lope Hardwood Decking, All-Coast Forest Products, Inc.; 800-767-2237; www.all-coast.com/paulope.htm.

Pau Lope by SKC Ltd., General Woodcraft, Inc., New London, CT 06320; 860-444-9663 or 7524; www.paulopedecking.com.

Penofin (Wood sealers), Performance Coatings, Ukiah, CA 95482; 800-736-6346; www.penofin.com.

Rainforest Alliance, New York, NY 10021; 212-677-1900; www.rainforest-alliance.org

Scientific Certification Systems, Oakland, CA 94612; 510-832-1415; www.scs1.com

Brock Deck (100% virgin PVC decking), Royal Crown Ltd., Milford, IN 46542-0360; 800-365-3625 or 219-658-9442; www.royalcrownltd.com.

DreamDeck (extruded from 100% vinyl), Thermal Industries, Pittsburgh, PA 15221; 800-245-1540; www.thermalindustries.com.

Iron Woods® Ipe (Insect-Resistant Species Hardwoods), Timber Holdings, Milwaukee, WI 53209; 414-445-8989; www.ironwoods.com.

TimberTech (wood/ plastic resin composite hollow profile boards fit together in a T&G design without exposed fasteners), Crane Plastics Columbus, OH 43216; 800-307-7780 or 614-443-4891; www.timbertech.com, www.crane-plastics.com.

Timbrex (approximately 50% wood fiber and 50 percent plastic), Trex Company, Winchester, VA 22601; 800-289-8739 or 540-678-4070; www.trex.com.

Carefree Decking (100% recycled plastic decking), SmartDeck®Systems (composite lumber made from recovered wood and recycled plastic), DuraWood EX (crosslinked wood fiber/ polymer composite made from 70% recovered and recycled wood waste and recycled milkjugs with hollow centers can hide cabling within deck), and DuraWood PE (100% post-consumer polyethylene plastic lumber), USPL Corp., Chicago, IL 60608; 888-733-2546 or 312-491-2500; <http://www.uspl-ltd.com/>

ZCL Composites, Inc. Nisku, Alberta, Canada, T9E7Z3; 800-990-3099; www.ezdeck.com.

ESSENTIAL KNOWLEDGE

Typically, any wood within 6" of finish grade should be factory treated or have natural rot and insect resistance, such as heartwood of cedar, redwood, black locust, and Ipe. The three primary methods of manufacturer-treated wood are: creosote pressure-treated wood; pentachlorophenol pressure-treated wood; and inorganic arsenic based pressure-treated wood. Coppernaphthenate, zinc naphthenate, and tributyltin oxide wood treatments can be site-applied. All of these treatment processes involve dangerous chemicals, and you should use material treated according to American Wood Preservers Association standards. While pressure-treated "green" Southern yellow pine is used in 80% of all decks, there are several alternatives even within the pressure-treated (PT) lumber category. Pressure-treated lumber should be used only in well ventilated areas. Rubber or vinyl gloves should be worn when handling the material, and a dust mask and goggles when cutting it (use sizes and lengths of treated wood that require no cutting, if possible). Newly cut surfaces should be protected with wood preservative solution applied according to manufacturer's directions. Pentachlorophenol treated wood should not be used where people, pets, or plants are likely to come into contact with it.

Typically, decks should not be painted since paints and solid-color stains can not hold up to the severe weather exposure from sun and rain. As small cracks develop in the paint layer on the deck's surface, water can pass through the crack and under the paint layer, and the paint will soon begin to peel. Also, the typical wood species used for pressure treated lumber is southern pine. This type of wood does not hold paint well since it expands and contracts. The U.S. Forest Products Lab has shown that semi-transparent stains and clear finishes actually last longer on chromated copper arsenate (CCA) pressure-treated wood than wood with other types of pressure treatment, since the chromium in the CCA treatment protects the wood surface from ultraviolet light and UV degradation. Paints and solid-color stains will perform well on pressure-treated wood that is used in an upright position (on fences, for instance), but only when the wood has been cleaned and is thoroughly dry before painting.

Since penetrating finishes do not form a film, they can withstand sun and rain and are much more suitable for decks. Decks should be finished either every year or two with a penetrating semi-transparent stain or a penetrating clear finish designed for use on decks.

TECHNIQUES, MATERIALS, TOOLS**1. USE WOOD WITH FACTORY-APPLIED PRESERVATIVES.**

Chromated copper arsenate (CCA) is one of the most popular insecticides and wood-preservative treatments. The chemicals are inert within the material and offer protection from moisture and decay fungi. However, the chemicals do not penetrate all the way into the heartwood. It is recommended that a sealer be applied to the cut ends of CCA-treated wood and be reapplied to the whole member periodically. Southern yellow pine is usually treated with CCA. Use wood with a CCA density of 0.40 for decks and joists and 0.60 for posts. When using CCA-treated lumber, the designation LP-2 is for above-ground use; LP-22 is for locations with soil contact.

Amoniacal Copper Quaternary (ACQ) is a new wood preservative that is less toxic than CCA and performs similarly to CCA, but does not contain arsenic, chromium, or other EPA classified hazardous preservatives, which are components in CCA-treated woods. The treated wood has a longer life than redwood or cedar and more consistent quality than plastic-wood products. ACQ weathers to a natural brown tone and can be used in environmentally sensitive settings. The wood scraps can be disposed of by ordinary trash collection.

Treated wood may be disposed of by bringing it to a licensed sanitary landfill or wrapped in paper and included with other household garbage. Treated wood should not be burned. Wood treated with any of the commonly used wood preservatives when burned produces highly toxic compounds in the smoke or ashes. Treated wood from construction sites may be burned only in commercial or industrial incinerators and boilers in accordance with state and federal regulations. If replacing decking, consider

factory pressure-treated wood with a water repellent, such as Hickson's Thompsonized PT (Pressure Treated) or Osmose's Armor All PT.

ADVANTAGES: Economical and plentiful, pressure-treated wood lasts approximately 15 years if properly treated with a water repellent every two years. Widely available.

DISADVANTAGES: The dominant pressure treated species is southern yellow pine, which will check and splinter as it dries. Pressure-treated wood should be carefully chosen for structures that will be used by children, as chemical residues may cause health problems.

2. APPLY NON-TOXIC FINISHES, STAINS, AND CLEANERS.

Pressure treating makes a wood surface more porous and susceptible to moisture damage. Penetrating sealers protect decking from moisture, and some also block damaging UV rays. Sealers usually need to be reapplied every year or two. Over time the wood surface may become rough and small cracks are likely to develop. Eventually, nails and fasteners will loosen and deckboards may develop checks. Urethane, shellac, latex, epoxy, enamel and varnish are acceptable sealers for penta-chlorophenol treated wood. Low-VOC, low-odor sealers are less harmful to the environment and work just as well. The low-VOC formulations are suitable for decks in areas near water and wetlands. For long-term protection wood surfaces can be coated with a water-resistant paint or stain. Water repellents and water-repellant preservatives slow the uptake of water and help keep wood dry. The only difference between these finishes is that water-repellant preservatives include a fungicide or mildewcide. Both contain a 10% to 20% binder such as varnish resin or drying oil (linseed or tung oil), a solvent, and a substance that repels water (wax or wax-like chemical). Prior to finishing, old paint must be removed and the surface sanded thoroughly in order for the paint to adhere. A primer may be necessary depending on the type of paint (follow application instructions).

ADVANTAGES: Wood preservatives help maintain the structural integrity of the material.

DISADVANTAGES: Wood preservatives should not be applied within 150 feet of a water source or wetlands area, or near a drinking water well.

3. APPLY BORATE-BASED PRESERVATIVES.

Borate products are available for site application. For preservation of wood not exposed to water, boron is a water-soluble preservative that automatically moves into areas where high moisture content has led to decay and insect infestations. It provides relatively non-toxic protection against wood-destroying beetles, fungus, and termites (upwards of 20 to 50 years), and helps increase the fire resistance of the wood. Borates can be applied by spraying, brushing, injection, and with the use of foggers. Boron penetrates the wood through osmosis. The treatment works best if the wood is slightly damp (this can be accomplished by slightly wetting the wood prior to application). The ideal treatment is to submerge fresh-sawn lumber in a vat of boron solution for a while, though it is regularly used on existing structures to stop or prevent insects and rot. In very wet climates, it may be necessary to retreat the wood every few years. Wood just treated with borates should be protected from rain or snow. Nisus sells a water repellent concentrate, Co-Pel, that can be mixed in with the Bora-Care for partially exposed timbers. U.S. Forest Products Laboratory research suggests that a water repellent should be reapplied to the exposed surface of the wood every two to three years. If this is done, there should be enough borate remaining in the wood to provide adequate protection.

ADVANTAGES: Relatively non-toxic; relatively easy to apply in a variety of ways.

DISADVANTAGES: Borates will leave a slight whitish discoloration.

FURTHER READING

Water Repellents and Water-Repellent Preservatives for Wood, R. Sam Williams and William Feist, USDA Forest Service, ForestProducts Laboratory, Report FPL-GTR-109, Madison, WI, 1999;
<http://www.fpl.fs.fed.us/documnts/FPLGTR/fplgtr109.pdf>.

Selection and Application of Exterior Stains for Wood, R. Sam Williams and William Feist, USDA Forest

Service, Forest Products Laboratory, Report FPL-GTR-106, Madison, WI, 1999;
<http://www.fpl.fs.fed.us/documnts/FPLGTR/fplgtr106.pdf>

“Disposal: The Achilles’ Heel of CCA-Treated Wood,” *Environmental Building News*, Volume 6, No. 3, March 1997; http://www.ebuild.com/Archives/Features/Treated_Wood/Treated_wood_disposal.html

“Pressure-Treated Wood: How Bad is it and What are the Alternatives?” *Environmental Building News*, Volume 2, No. 1, 1993, pp. 1-13; www.ebuild.com.

PRODUCT INFORMATION

Auro Borax Wood Impregnation No. 111, Auro Products, Sinan Company, Davis, CA 95617-085; 916-753-3104; 530-753-3104; www.dcn.davis.ca.us/go/sinan/.

ACQ Preserve and built-in water repellent (marketed as PreservePlus), Chemical Specialties Inc., Charlotte, NC 28217; 800-421-8661; www.treatedwood.com.

BORA-CARE (termiteicide, insecticide, and fungicide concentrate and CO-PEL water repellent used over BORA-CARE treated wood), Nisus Corporation, Rockford, TN 37853; 800-264-0870 or 615-637-1226; www.nisuscorp.com.

Borate pressure-treated lumber by Caribbean Lumber Co., Savannah, GA 31498-2687; 912-748-7800.

Impel Rods (site-applied borate rods), Ultrawood (water-repellant treated wood), and Preserve (arsenic-free treated wood), Chemical Specialties, Inc., Charlotte, NC, 28217; 800-421-8661; www.treatedwood.com.

NatureSeal 100 (low-VOC waterproofing wood primer/sealer), Seal-N-Protect, Allentown, PA 18104; 610-366-7931; <http://hometown.aol.com/naturesseal>.

Osiose Weathershield (water repellent, wood sealers, wood stains, wood water repellants, wood brighteners), Osiose Wood Preserving, Buffalo, NY 14209; 800-241-0240; www.osiose.com.

Pro-Tech 2000 (low-VOC Soy based wood and concrete sealer) NiconMidWest (NMW) Inc., Indianapolis, IN 46226; 800-253-4237, 317-898-0292.

Tim-Bor borate powder, lumber, and plywood, U.S. Borax and Chemical Corp., Valencia, CA 91355; 800-872-6729 or 661-287-5400; <http://borax.com>.

2.4

STAIRS AND HANDRAILS

ESSENTIAL KNOWLEDGE

Handrails are required on at least one side of all stairs with three or more risers and ramps with a slope of 1:12 or more. The recommended height of handrails is a minimum of 30” and maximum of 38”. The recommended perimeter of a handrail is 4” to 6 1/4”. Wood handrails and their supporting posts, and wood stairs are subject to rot from standing water, and infiltration of water into fasteners. Some rotted portions of the material can be replaced without having to replace the entire handrail, supporting post, or stair treads. Rotting problems can be serious and must be corrected before replacing the material.

TECHNIQUES, MATERIALS, TOOLS

1. ADD SUPPORT TO EXISTING RAILING POSTS.

If railing posts are nailed in place, they can be re-nailed or stabilized with lag bolts for additional support. Bore pilot holes for the lag bolts and counter-bore holes in the posts so that the lag bolt head and washer

will be recessed below the railing post surface. Re-nailing handrails to posts will secure the handrails too.

ADVANTAGES: Re-nailing or bolting provides more support; relatively low cost.

DISADVANTAGES: Bolting posts requires more work than re-nailing.

2. REPLACE EXISTING WOOD RAILINGS.

Wood rot usually occurs where two or more pieces of wood intersect or where wood is fastened. When replacing a portion of a handrail that has rotted, cut out the rotted section using a diagonal scarf joint. After measuring a new piece from treated lumber, use waterproof glue and galvanized screws to attach the new piece. If the railing is attached with a bracket, tighten all of the screws in the bracket. If the screws cannot be tightened and are loose, use longer screws in the holes, or install a new bracket with holes in new positions (Fig. 5). If the handrail is separated from the post, fasten a 2x4 block under the handrail onto the post for support, or use a metal angle bracket that is fastened to both the handrail and the post. For a bottom handrail that has come loose from its post, use a metal T-connector plate fastened to the end of the handrail and at the side of the post.

ADVANTAGES: Replacing only rotted section of wood conserves time and materials.

DISADVANTAGES: Handrails may be rotted in several areas, thus requiring replacing several sections. Multiple sections may be unsightly compared to one continuous handrail.

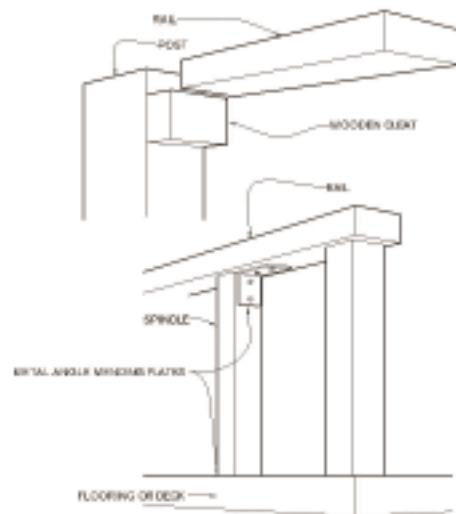

FIGURE 5

WOOD RAIL SUPPORT

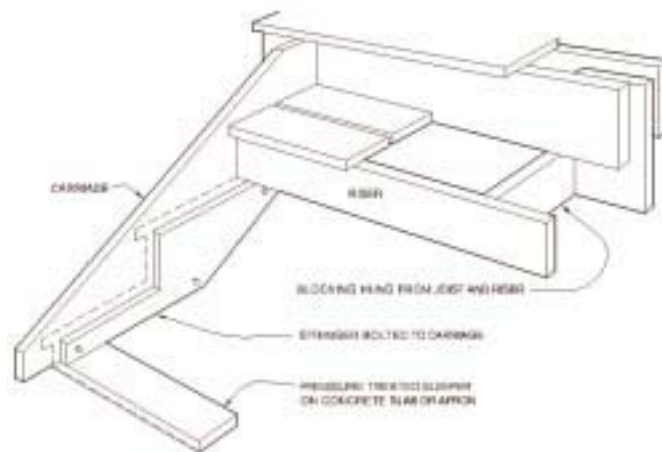

FIGURE 6

EXTERIOR STAIR ELEMENTS

3. REPLACE DAMAGED WOOD TREADS OR RISERS.

To remove a damaged tread on exterior stairs (Fig. 6) saw through the middle and remove the pieces from the stringers with a prybar. Cut a new tread from pressure-treated lumber, matching existing tread depth and thickness. Treat the cut ends with preservative. Attach to the stringers with 16d galvanized nails or galvanized deck screws (deck screws will secure the treads more tightly to the stringers). If risers are damaged, remove the tread first to access the risers and replace.

ADVANTAGES: Replacing only damaged treads is time and resource efficient; low-cost fix.

DISADVANTAGES: If treads are subject to rot, the problem should be corrected before replacing material.

4. REPLACE DAMAGED STRINGERS.

If wood stair stringers are partially rotted, they should be replaced. Replace with pressure-treated wood of the same size (usually 2x10 or 2x12). Use the old stringer as a pattern for the new stringer. Stringers should rest on a pressure-treated sleeper if the wooden stair ends on a concrete pad. Stringers and cleats should be bolted to the carriage (Fig. 7).

ADVANTAGES: Replacing only damaged stringer is time and resource efficient; low-cost fix.

DISADVANTAGES: If stringers are subject to rot, the problem should be corrected before replacing material.

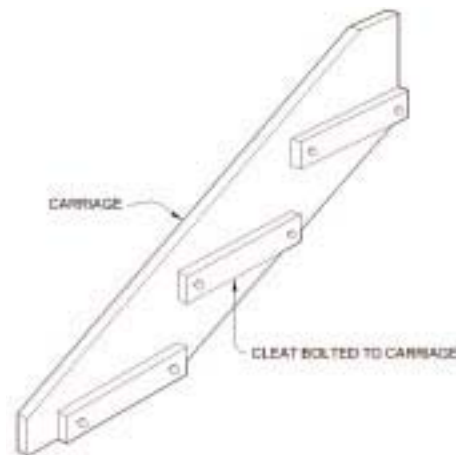

FIGURE 7

BOLTED CLEATS ON CARRIAGE

FURTHER READING

Renovation: A Complete Guide, 2nd Edition, Michael Litchfield, Englewood Cliffs, NJ: Prentice Hall, 1991.

PRODUCT INFORMATION

See 2.3 PRESERVATIVE-TREATED WOOD.

WOOD FENCES AND RETAINING WALLS

ESSENTIAL KNOWLEDGE

While some fences are meant to decorate lawns and gardens, others are meant to create barriers and privacy. A well maintained fence will contribute to both privacy and yard maintenance. Posts are the vertical elements of a fence that are anchored into the ground, and rails are the horizontal members. Fences will collapse if the post supports are inadequate. This can result from rotted post bases, or post bases can overturn if not set deep enough or are set with insufficient concrete. Wood fence posts are usually guaranteed for 20 years if professionally installed. Fence posts should be inspected regularly for rot and damage. At the point where the post meets the ground, if the wood is not painted, a coat of wood preservative should be applied yearly. Paint or preservatives should be applied to the entire fence every few years.

TECHNIQUES, MATERIALS, TOOLS

1. STRENGTHEN AN EXISTING WOOD FENCE POST.

If fence posts are wobbly, dig down along one side of the post to check for rot. If the lower section does not flake or feel spongy, the post may only need to be reset in its hole. If physical inspection reveals that many posts are rotted, entire replacement may be warranted. If a wooden post is loose, support can be added by driving pressure-treated 1x4 stakes into the ground on either side of the post (Fig. 8). Apply a wood preservative to the stakes prior to putting them into the ground. Then nail the stakes to the post. If the post has been pushed upwards by frost heaves, drive the post back into the ground with a mallet or sledge hammer or anchor the post in concrete. Tighten fasteners that are popping out between the post and rails, or add fasteners for additional strength. Wobbly posts set in concrete can be strengthened by pounding the concrete into the ground with a sledge hammer, then pouring at least 6" of concrete over the area. To plumb a leaning post, rails, and screening, drive groundstake on the opposite side of the direction of lean. Attach an eye screw to the middle of the leaning post and, using a winch and cable attached to the eye screw, tighten the cable until the fence is plumb.

ADVANTAGES: A quick and easy way to fix a fence post; low-cost remedy. Salvageable pieces can be restored to make this approach more resource efficient.

DISADVANTAGES: Not a long-term solution. Posts with rotted ends should be replaced.

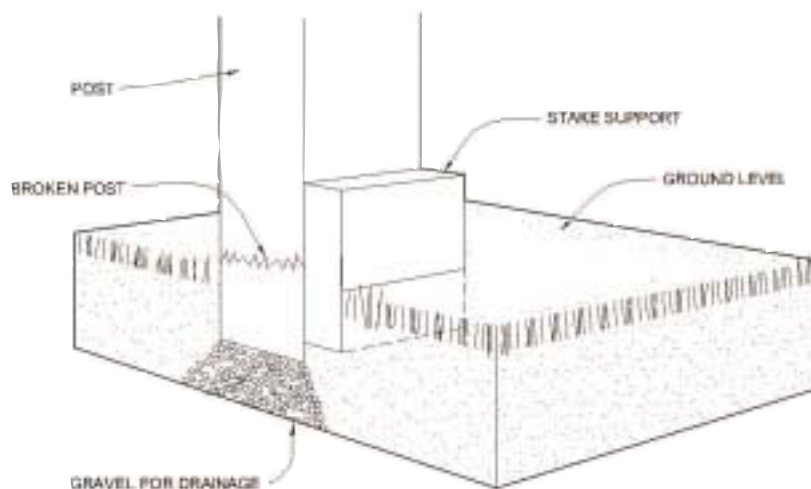

FIGURE 8

STAKE POST SUPPORT

2. REPLACE A WOOD FENCE POST.

Fence posts that need to be replaced can be removed from the ground by first removing the screen and rail boards from the post. To replace only the bottom portion of a rotted post, cut the post at ground level while it is attached to the fence rails, then remove soil from around the post bottom. Remove the rotted portion of the post. Cut a brace or “sister” post approximately 5’ long from pressure-treated lumber suitable for in-ground contact. Redwood and cedar will rot in moist ground, so use a galvanized angle iron set in the concrete, bolted to the wood post above ground. Treat with a wood preservative before placing the new post into the hole. Angle-cut the top of the new brace post for water runoff. The new brace post should rest on a bed of gravel and extend 2’ to 3’ out of the ground (Fig. 9). Fasten it to the old post with two 1/2” carriage bolts. Make sure the post is plumb and fill the hole with rocks or broken pieces of brick to make it secure.

To anchor a new post in concrete, add the ready-mix concrete and water after the post has been inserted into an 8”- to 12”-diameter hole. Add gravel to the hole up to the base of the post. Holding the post vertically in the hole, pour about 3” of concrete mix into the bottom of the hole. Add water and tamp. Add more concrete mix, water, and tamp it again, until the post hole is full.

ADVANTAGES: Relatively easy, low-cost remedy.

DISADVANTAGES: Even if treated with a preservative, moisture in the ground will wick up into post and can lead to rot. Setting the new wood post in concrete will help prevent the flow of moisture from the ground into the new post.



FIGURE 9

BRACE OR “SISTER” POST

3. STRENGTHEN AN EXISTING WOOD FENCE RAIL.

Usually a rail begins to rot where it is attached to a post, due to water infiltration. Add a pressure-treated corner block under the rail at the post and attach it to both with galvanized fasteners (similar to technique for supporting a porch rail, Fig.5, p.17). If the rail is rotted between two posts, cut the affected section out and scab a wood connector piece to the outside of the rail using galvanized nails or two 1/2” carriage bolts. If the area of rot is extensive throughout the rail, attach a full-length rail to the damaged rail with galvanized screws every 20”. Secure the new rail to the posts with cornerblocks or corner angle braces.

ADVANTAGES: Replacing only the portion of rail that is damaged is time- and resource-efficient.

DISADVANTAGES: Repair work may show differences in materials.

4. REPLACE AN EXISTING WOOD FENCE RAIL.

To replace rotted rails, first remove the screen boards. This is best done by splitting the rail in two before removing the screen boards. Make sure to mark the order of the screen boards prior to removal. Remove any extra nails in the screen or rail boards. Cut a piece of pressure-treated lumber and test the new rail

piece for fit between the two posts. Paint the new rail before installation. Level the rail between the posts and fasten to with nails or a metal hanger. Replace screen boards in their original order.

ADVANTAGES: Replacing only part of the fence saves time and material.

DISADVANTAGES: Repair work may show differences in materials.

5. REPLACE DAMAGED WOOD FENCE SCREENING (PICKETS).

Fence screening that has become loose from the rails should be re-nailed or fastened with new nails or screws. If the screening needs replacement, remove the old boards and apply a wood preservative or finish to the new boards before installing them. Apply a wood preservative to all cuts in treated lumber. Should the boards be attached to the rails with cleats, remove one cleat and then slip the board out without having to remove the other cleat. When reattaching the screen boards, check to be sure that the boards are vertical before nailing them to the rails. Wood screen boards will sometimes rot when water collects under them at grade. A remedy is to install a drainage path by digging a shallow trench under the fence then filling it with gravel or crushed stone.

ADVANTAGES: Relatively easy, low-cost repair.

DISADVANTAGES: Conditions contributing to rot should be corrected before repair.

6. STRENGTHEN A SAGGING WOOD GATE.

A sagging wood gate may be difficult or impossible to close. Replace the hinges on the gate if they are rusty or loose. If the post that the gate is hinged to is not vertical, it can be plumbed (see 1. STRENGTHEN AN EXISTING WOOD FENCE POST, above) or replaced (see 2. REPLACE A WOOD FENCE POST). If the gate itself is out of plumb and sags, it can be squared up with a turnbuckle (Fig. 10). Install an eye screw on the gate near the top hinge. Position another eye screw on the gate diagonally across from the first, near the bottom of the gate on the latch side. Attach wire to each end of the turnbuckle (the turnbuckle's screw and threads should be just barely engaged). Cut the wires so that the total length of the turnbuckle and both wires is equal to the distance between the two eye screws plus 8". Insert each wire end into an eye screw, pull the wire taut, and wrap the remaining 4" of wire around the eye screw. Tighten the wire by turning the turnbuckle with pliers until the gate is plumb. An alternative method is to remove the gate and lay it on a flat area, square it, and then attach a wooden diagonal cross-brace on the back of the gate with galvanized screws or nails.

ADVANTAGES: Relatively easy, low-cost repair.

DISADVANTAGES: If the gate sags because of rotted material, it may be necessary to completely replace it.

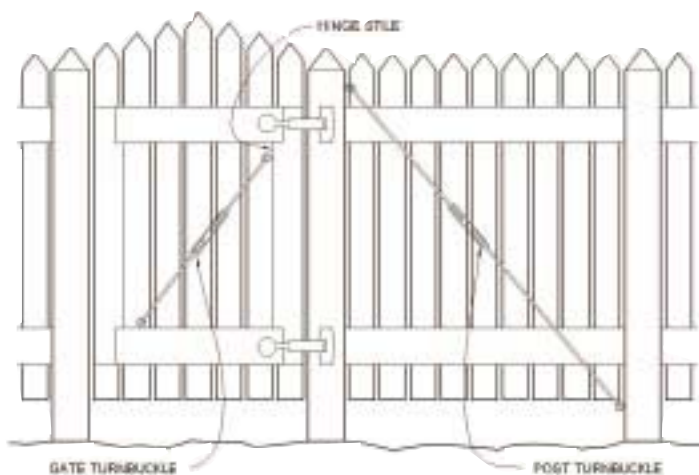

FIGURE 10

SAGGING GATE REPAIR

7. REALIGN A TIMBER RETAINING WALL.

Timbers and railroad ties in a retaining wall can become misaligned due to lateral forces pushing the wall out. One technique is to carefully remove the timbers one-by-one and restack them (it is best to do this during a dry spell so that the retained earth has little water). After the timbers are realigned and restacked they can be pinned in place by driving long gutter spikes through the edges of the ties. For more stability, drive two 1x4 or 2x4 stakes into the ground behind the retaining wall and then nail the stakes to the ties. If you cannot access the back of the wall, bore two holes into the top of each timber as it is restacked, then align the holes using a reinforcing rod. Drive the rod into the ground so that the top of the rod will be flush with the top of the wall. If all the timbers are removed, restack them on a 6" trench filled with gravel for drainage.

ADVANTAGES: Materials are conserved if the timbers can be reused.

DISADVANTAGES: Over time, timbers will likely become misaligned again unless they are pinned together.

FURTHER READING

Build You Own Walls & Fences, Penny Swift and Janek Szymanowski, London: New Holland Publishers Ltd., 1997.

The Stanley Complete Step-by-Step Book of Home Repair and Improvement, James A. Hufnagel, New York: Simon & Schuster, 1993.

3

PAVED DRIVEWAYS, WALKS, PATIOS & MASONRY WALLS

3.1

PAVED DRIVEWAYS, WALKS, & PATIOS

ESSENTIAL KNOWLEDGE

For walks and driveways, the two main paving materials are asphalt and concrete. With proper maintenance these materials should withstand years of use. These paving materials are both susceptible to freeze/thaw cycles in temperate regions, which can cause asphalt and concrete to crack and crumble. The use of road salts to melt snow in cold climates contributes to the deterioration of concrete. It is important to maintain paving in areas where the temperatures vary from one season to another. Heat can cause a concrete slab to expand and buckle and extreme cold can heave and crack a slab. Ice can cause the surface of concrete to chip and spall.

It is recommended that concrete slabs be inspected every spring. Check the edges of the slab for erosion. If a sidewalk or driveway slopes, water erosion problems along the edges of the slab are common. Water will begin to wash away the borders until it undercuts the gravel base beneath the edges of the concrete slab, thus leaving the slab unsupported. Check the edges along the slab and refill any eroded or washed out areas with gravel, dirt, or sod.

Concrete paving is usually 4" of concrete over a 4" gravel base. Asphalt paving is 2" of asphalt over 4" of gravel base. Precast concrete pavers are also available and are less costly than either concrete or asphalt. Asphalt is a good choice for driveways and sidewalks. It works best in climate areas that do not have freeze/thaw cycles. Asphalt costs less than concrete and can last almost as long.

There are basically three delivery methods for concrete: ready mix from plant, pre-mixed concrete by the bag, or pre-mix with a power mixer. Ready mix from a plant will have Portland cement, gravel, sand, a water-reducing agent, an air-entrainment agent, and water. A standard mix will reach 3,000 psi compressive strength in 28 days. For a stronger mix more Portland cement is added. Since each component is weighed precisely by computer, the concrete from a plant will be a predictable mix. The water-reducing agent allows a lower volume of water to be added, thus reducing the amount of concrete shrinkage. The aggregate size can be anywhere from 1/4" to 1", unless specified otherwise. The amount concrete shrinks decreases as the aggregate size increases. The air-entrainment agent helps the finished concrete to resist freeze/thaw cycles. Additionally, polypropylene fibers can be added to reduce cracking of the concrete.

Pre-mixed concrete by the bag sold at retail building suppliers should conform to the ASTM C-387 Standard, yielding a minimum of 3,500 psi after 28 days. Some manufacturers offer fiber-reinforcing, for crack reduction, available in pre-mixed bags. The aggregate size in premixed bags ranges from 3/8" to 9/16". The pre-mixed bags will probably not include either the water-reducing agent or the air-entrainment agent. Each bag will yield about one-half cubic foot.

1. SEAL ASPHALT PAVEMENT.

The life of the asphalt pavement can be greatly extended with the yearly application of a sealer. The driveway should be sealed after filling potholes and cracks. This will help the patch adhere to the existing asphalt and not pop out when expansion or contraction occurs. The sealer will also cover over all crack and hole repairs to give a uniform, even appearance.

ADVANTAGES: Sealer will help preserve the surface and prevent small, hairline cracks from growing larger and letting water seep in under the slab, causing potholes.

DISADVANTAGES: A good sealer should be used, as some sealers are merely cosmetic.

2. REPAIR CRACKS IN ASPHALT.

Cracks greater than 1/8" cannot be properly repaired with sealer and should be repaired with a crack filler designed specifically for the purpose. Asphalt crack filler is available in a caulking tube.

ADVANTAGES: Cracks are easily filled; a low-cost remedy.

DISADVANTAGES: After cracks are filled, the surface should be sealed.

3. REPAIR HOLES IN ASPHALT.

As water seeps through cracks in asphalt pavement, it undermines the gravel and earth bed beneath the surface. This will cause the asphalt to cave in and form a pothole. Cold patch or black top patch should be used for pothole repair. The hole should be cleaned out of all loose asphalt pieces, and undercut (Fig. 1) so that the patch will bond and not pop out. Follow manufacturer's instructions, filling the hole and tamping it to compress the material.

ADVANTAGES: Depending on extent of patch, a relatively low-cost repair.

DISADVANTAGES: Pothole may return if gravel is washed out below the asphalt surface.

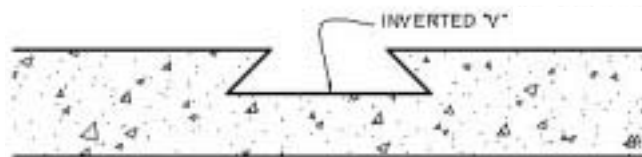

FIGURE 1

UNDERCUT HOLE FOR PATCH

4. REMOVE STAINS IN CONCRETE PAVING.

Stains on concrete surfaces may be caused by both organic and inorganic chemicals or by growth of fungus. Effective stain removal begins with matching the cleanser to the stain. There are two general methods of removing stains: physical and chemical. A combination of the two may be needed. Physical methods include sand blasting, grinding, steam cleaning, brushing, scouring, or blow torch. Wire brushes should not be used, as the wire can become imbedded in the concrete and cause rust stains.

Chemical solvents dissolve stains or react with them to form a compound that will not show the stain. Solvents can be applied directly on the surface. They can also be applied by soaking a cotton cloth and placing it on the concrete. This is done to keep just enough chemical at the surface of the concrete to complete the chemical reaction. Mix the solvent and a finely ground powder such as whiting (calcium carbonate), hydrated lime (calciumhydroxide), talc, or diatomaceous earth and spread it on the stained area in a 1/4" to 1/2" layer.

If the slab is not oil stained, clean it with a strong solution of trisodium phosphate (TSP). Scrub food stains with hot water and soap (for tough food stains, cover the spot with a wad of cheesecloth soaked in a solution of one part glycerin, two parts rubbing alcohol, and four parts water). Keep the cheesecloth in place until the stain is absorbed.

For motor-oil stains, saturate them with paint thinner, then cover with cat litter. Leave the litter in place overnight. Repeat the process if the stain persists, then scrub with a strong cleaner. Finally, apply full-strength chlorine bleach, wait 15 minutes, and rinse it off with water. Another option is to use a pre-mixed concrete-degreasing solution or a cleaner/degreaser. Another technique is to sprinkle dry Portland cement over motor oil stains until all the oil is absorbed, then remove the powdered cement.

Rust stains can be removed with an acid solution of one pound of oxalic acid in one gallon water. Carefully apply the solution to the stain, let sit for two hours, then rinse with water. Old stains may require several treatments.

ADVANTAGES: There are many concrete cleaners and degreasers which are less toxic than acids.

DISADVANTAGES: Cause of the stain may be difficult to determine; several stain treatments may be needed.

5. SEAL CONCRETE PAVING.

Water under a concrete slab may freeze and expand causing the surface to crack. Sealers protect the concrete from stains, producing fine dust particles that enter the house, and damage due to water penetrating the surface of the slab. Concrete sealers can provide a surface that is resistant to scaling from the use of de-icers. Rust and oil usually do not penetrate sealed concrete and are more difficult to remove from unsealed concrete. After you have patched or resurfaced the concrete slab, apply at least one coat of a water repellent sealer. Clear concrete sealers can be applied with a roller, brush or sprayer.

ADVANTAGES: Sealers prevent oil and antifreeze from being absorbed by the concrete.

DISADVANTAGES: Concrete sealers are not impervious to grease that saturates the surface. They have to be reapplied every few years depending on the product and the conditions. No matter how good a sealer is, it will eventually wear off and be ineffective.

6. REPAIR CRACKS IN CONCRETE.

Liquid cement crack filler, available in a caulk tube, should be used to seal the crack. Clean old caulk or patching products from cracks before refilling with a new patching material. Cracks up to 3/8" wide can be repaired using either a mix of latex concrete bonding liquid and Portland cement, available as a repair kit, or a ready-mixed concrete patch product available in a caulk tube. For narrow cracks, use concrete caulk, a ready-mixed liquid repair product for better penetration. Small holes, or "pops," can be filled with Portland cement. Concrete bonding liquid provides a better bond between the old concrete and the new patch than does plain water.

Before repairs, oil and grease stains should be cleaned. Using a mason's or cold chisel, break away loose or cracked concrete to create a V-cut. Clean loose material from the crack, then remove any loose dust or concrete particles. The damaged area should not have any loose dust that could prevent proper bonding. Apply a thin layer of bonding adhesive to the entire repair to help keep the repair material adhered to the crack. Trowel the latex patching compound into the crack, making it even with the surrounding surface. For large patches, after cleaning pour sand into the crack to within 1/2" of the surface. Prepare sand-mix concrete by adding a concrete fortifier. Trowel the mixture into the crack and smooth.

ADVANTAGES: Repairing cracked concrete prevents moisture from damaging reinforcing; small crack repair is relatively easy to accomplish.

DISADVANTAGES: Large crack repair may be a significant undertaking; new concrete may be needed.

7. REPAIR A SUNKEN CONCRETE WALK OR DRIVE.

To level a small portion of a sunken concrete slab such as a sidewalk, first bore two 1" diameter holes, 1' apart, through the lower side of the slab. Then pry the slab up with a lever until it is level. Mix cement, sand, and water to pour into the holes. For good drainage along the slab edges, redirect water away from these areas by filling any accessible voids beneath the concrete with gravel.

ADVANTAGES: A relatively easy way to fill the void beneath a slab to prevent further sinking.

DISADVANTAGES: If erosion of gravel and soil beneath slab continues, surface will sink again.

8. PATCH CONCRETE.

For large areas of damage or spalling that cannot be repaired as cracks, remove any loose concrete particles with a hammer and cold chisel or stiff bristle brush, and vacuum. Mix the concrete patching material and use a knife or trowel to spread the material over the hole, or use a pourable concrete patch material (Fig. 2). Overfill the patch area, then use the patching tool to compress and level the patching material.

ADVANTAGES: A relatively simple, low-cost repair, provided damaged area is not extensive.

DISADVANTAGES: Repair should be done in weather that is warm but not too hot.



FIGURE 2

POURABLE CONCRETE PATCH

9. REPAIR CRUMBLING CONCRETE.

Repair small broken areas of a slab, curb, or step with standard concrete or a concrete patching product (Fig. 3). If you use standard concrete, apply a concrete bonding adhesive (commonly available) to bind the old concrete to the new. Apply the patching compound according to manufacturer's instructions. If the damaged area is deep or large, bore holes through the slab and install some reinforcing bars into the existing concrete to tie it into the patched concrete.

ADVANTAGES: A relatively low-cost, easy repair if damaged area is not extensive.

DISADVANTAGES: Repair should be made when there are warm air and ground temperatures.



FIGURE 3

CONCRETE PATCH PASTE

10. RESURFACE CONCRETE.

If the concrete slab or steps are badly peeled or extensive repairs are needed, the surface can be renewed with a resurface product. Evidence of concrete surface damage is scaling and flaking of the concrete. This usually occurs from de-icing chemicals or water that has seeped into the concrete and frozen. To repair a scaled surface, apply a thin cement overlay system, which includes both a patching compound for deep holes and a thin coat as a resurfacer (Fig. 4). A concrete contractor can apply a special-formula thin overlay, such as A-300 Pourable Outdoor Concrete Topping from Ardex Engineered Cements. Pattern-stamped overlays may be used to match an existing finish texture. First, the overlay concrete is poured on, then it can be colored to imitate brick or stone. As the concrete hardens, a pattern is pressed onto the surface, leaving finishes that replicate brick, slate, or stone.

ADVANTAGES: Resurfacing is less labor intensive than pouring a new slab.

DISADVANTAGES: Resurfacing material should be applied when there are warm air and ground temperatures.



FIGURE 4

CONCRETE RESURFACING

11. LAY NEW CONCRETE NEXT TO EXISTING.

To add a small area of concrete next to existing material, it is important that the new footings for the slab addition match the footings under the old slab. Matching the new footings to the old ensures that winter frost will not heave the slab unequally. Usually a driveway slab is not attached to the house and is laid on a prepared grade at ground level. If a carport or garage is attached to the house, the footings must extend to the local frost line.

To prepare the area for a slab extension, remove all dirt and grass from the area. Compact the soil, since slabs poured on uncompacted soil will settle. A 3" to 6" gravel base spread over the compacted soil should extend 4" past the edge of the new slab. The concrete will be better supported by a deeper gravelbase. Install a layer of 6 mil plastic sheeting with overlapping, and wire reinforcing mesh over the gravel base. On top of this are placed 2x4 forms, which should be level with the surface of the existing slab. Install an expansion strip at the joint between the old and new slabs, to allow for movement. Use an edger to form a neat groove at control joints. After pouring the new slab, raise the reinforcing wire so it is in the center of the concrete slab. Wet the concrete three times a day for five days; remove the forms after 10 days. The new slab should not be driven on for about 30 days.

ADVANTAGES: Most practical way and cost-effective to repair large areas of damaged concrete slab.

DISADVANTAGES: Concrete mix used for the extension slab should be as similar as possible to the concrete mix used for the original slab (for fewer expansion and contraction problems).

12. REPAIR OR REPLACE DAMAGED CONCRETE STEPS.

To repair damaged concrete steps, first patch any holes and fill any cracks. Enlarge small holes to 1" depth, minimum, then clean out hole with stiff brush or compressed air. Rinse and let dry. Apply a liquid bonding agent before filling the hole with new concrete or apply a concrete patching compound. For cracks, enlarge the crack to get a good bond and fill with concrete patching compound or expansive mortar. If there are signs of water seepage in the steps, use hydraulic cement for patching. If the nose of a step is chipped, place a board in front of the nosing along the front edge of the riser (Fig. 5). Using heavy stones to hold this form in place, fill with concrete and let cure before removing form. If a concrete stair corner has broken off, use a latex-based ready-mix or a sand-cement-epoxy mix. Pre-cast concrete steps are inexpensive and can be installed quickly.

ADVANTAGES: Repairing concrete steps by patching is easier than replacing them or repouring them.

DISADVANTAGES: Concrete patches may not hold if the repair area has not been cleaned properly before repair.

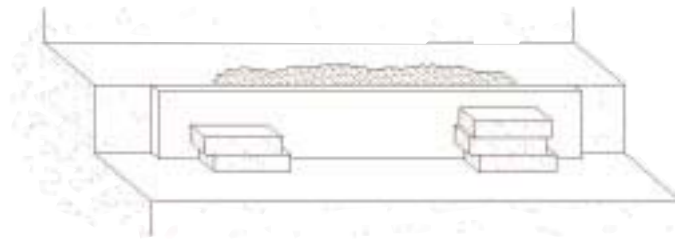

FIGURE 5

CONCRETE STEP REPAIR

13. REPAIR STEEL HANDRAILS.

Steel handrails are most often used on concrete or masonry steps. If the post and handrail are in good condition but the post is loose, unscrew the post at the bottom, and remove it from the bracket. Pull out the metal bracket if it needs to be replaced. To do this, enlarge the area in the concrete where the bracket was with a masonry drill. Clean out the hole with water and let it dry. Using masonry anchoring cement or an epoxy, install a new bracket into the hole. Wait 24 hours before screwing the metal post into the new bracket.

ADVANTAGES: Relatively simple, low-cost repair.

DISADVANTAGES: Railings with significant rust should be replaced.

14. REPAIR BRICK OR STONE STEPS.

Check the mortar of the brick or stone steps. If the mortar is loose, but the bricks are tight, remortar the bricks. Remove the old mortar with a chisel. Clean out the joints. Place concrete into the joints with a tuck-point trowel. After the joints are packed with concrete, smooth the joint with the tuckpoint trowel. Should the bricks come loose, remove any concrete on them with a chisel. Wash the bricks and soak in a bucket of water. Lay a mortar bed equal in height to the rest of the steps or at least 1/2". Align the soaked bricks, then lightly tap them into the fresh mortar with a hammer. Next, place mortar in the areas between the bricks or stones. Trowel smooth the joints between the bricks.

ADVANTAGES: Relatively easy way to renew masonry steps.

DISADVANTAGES: Bricks or stones on steps may come loose again through frost heave.

FURTHER READING

Building Concrete Walks, Driveways, Patios, and Steps. Portland Cement Association (PCA), Skokie, IL 60077; 800-868-6733 or 847-966-6200; <http://www.portcement.org/concrete.htm>.

Building Quality Concrete Driveways Video, published jointly by NRMCA and Portland Cement

Association (PCA), 1990, 10 min.

Concrete Construction Handbook, 3rd edition, Joseph A. Dobrowolski and Joseph J. Waddell, eds., McGraw-Hill Handbooks, 1993. www.ConcreteNetwork.com/bookstore/concrete.htm.

Concrete Floors, Finishes and External Paving, Philip H. Perkins, <http://www.ConcreteNetwork.com/bookstore/concrete.htm>.

Concrete for Small Jobs, Portland Cement Association (PCA), Skokie, IL 60077; 800-868-6733 or 847-966-6200; www.portcement.org/concrete.htm.

Finishing Concrete Slabs with Color and Texture, Steven H. Kosmatka, Portland Cement Association (PCA), Skokie, IL 60077; 800-868-6733 or 847-966-6200; www.portcement.org and www.ConcreteNetwork.com/bookstore/decoconcrete.htm, 1991.

Guide for Selecting and Specifying Concrete Repair Material (No.03733) and *Guide for Selecting and Specifying Surface Preparation for Sealers, Coatings, and Membranes (No. 03732)*, Sterling, VA: International Concrete Repair Institute (ICRI).

Residential Concrete, 3rd Edition, American Concrete Institute (ACI) International, 1999.

Step-By-Step Masonry & Concrete, Benjamin W. Allen and Ben Allen (eds.), Better Homes & Gardens Books, September 1997.

The Homeowner's Guide to Building With Concrete, Brick and Stone, authored by the Portland Cement Association, Emmaus, PA: Rodale Press, 198.

PRODUCTS

ARDEX CD (resurface old, spalled or worn concrete surfaces), ARDEX A-300 (pourable outdoor concrete topping), ARDEX Poly-TopPolymer Concrete Patching Compound Ardex Inc., Coraopolis, PA 15108; 412-604-1200; www.ardex.com.

Abocoat (solvent-free, water borne, resurfacing system), AboWELD55-1 (repairing concrete stairs without forms), WoodEpoxy andLiquidWood (to fill and repair, can be sawed, nailed, and painted), Abatron, Inc., Kenosha, WI 53144; 800-445-1754 or 414-653-2000, www.abatron.com.

ChemRex Inc. (high-performance adhesives and sealants, wall and floor coatings, waterproofing membranes, concrete-repair products and stucco systems), Shakopee, MN 55379, 612-496-6000; www.chemrex.com.

CIA-Gel Epoxy (multi-purpose, solvent-free, low-odor, low toxicity, non-shrink formula for anchoring), Covert Operations, Long Beach, CA 90804; 800-827-7229 or 562-986-4212; www.covertoperations.com/oneprod.htm.

ConSeal (masonry patches and sealants), H & C (concrete and masonry waterproofing sealer), H & C Shield Plus (concrete stain), ConSeal Elastomeric Sealants, Sherwin-Williams, Cleveland, Ohio 44115; 216-566-2000.

VOCOMP-20 (water emulsion acrylic curing and sealing compound), SEALTIGHT ASPHALT (expansion joint filler), W.R. Meadows, Inc., IL.; 708-683-4500.

EliteCrete Systems, Inc. (acrylic polymer concrete overlay products for decorative concrete resurfacing and concrete repair/resurfacing), Advanced Technological, Valparaiso, IN 46383; 888-323-4445 or 219-465-7671, www.elitecrete.com.

Endur-o-Seal (low-VOC water-borne concrete sealer) and EPO-TOXY (solvent-free concrete repair epoxy compound), Lone Star Epoxies, Rowlett, TX 75030, 972-475-2501; www.lsepoxies.com.

Gibson-Homans Co. Inc., Twinsburg, OH 44087; 888-SHURSTIK; www.gibson-homans.com (adhesives, sealants including driveway-maintenance products, caulking and repair compounds).

Green Mountain International, Inc, Waynesville, NC 28786; 800-942-5151 or 828-456-9970; www.mountaingrout.com/.

Homex 300 concrete expansion joint filler (concrete and masonry joint filler made from 100% post-consumer recycled newsprint and contains no formaldehyde or asbestos), Homasote Co., West Trenton, NJ 08628; 800-257-9491; www.homasote.com/homex1.html.

INCRETE (stamped-in-place decorative concrete system), STAIN-CRETE (deep penetrating concrete stain for existing concrete), SPRAY-DECK (decorative non-skid concrete overlay system for existing concrete surface), STONE-CRETE (poured-in-place decorative concrete wall system for sound barrier walls, retaining walls), Increte, Tampa, FL 33634; 800-752-4626; 813-886-8811; www.increte.com.

Macco Adhesives, Cleveland, OH 44115, 216-344-7360, www.liquidnails.com.

PC-CRETE 300 (two-component, solvent-free exterior use polyurethane for repair of cracks and divots in concrete and masonry substrates), POLYGLAZE AR-SF (solvent-free, single component, urethane polyurea topcoat for waterproof concrete decks), Polycoat USA, Santa Fe Springs, CA 90670; 562-802-8834, www.polycoatusa.com/HTMWP/aquaga~1.htm.

PermaCrete's Perma-Bond Crack Repair, PermaCrete, Nashville, TN 37211; 800-60-PERMA or 615-331-9200; 615-834-1335 (fax); www.permacrete.com.

Sika Corp. (adhesives and sealants for masonry), Madison Heights, MI 48071, 248-577-0020, www.sikaUSA.com.

Symons Corporation, Des Plaines, IL 60018, 847-298-3200; <http://www.symons.com> (line of concrete repair and surfacing products).

Specco Industries, Inc., Lemont, IL 60439; 800-441-6646 or 630-257-5060; www.specco.com (concrete and masonry products including bonders, cleaners, coatings, epoxies, patching, sealers, surface treatments and water repellents).

Soy-Clean (biodegradable soy-based concrete cleaner, asphalt cleaner, graffiti remover, herbicide stain remover, paint stripper, driveway cleaner), Soy Environmental Products Inc., Kansas City, KS; 913-599-0800; www.ia-usa.org/k0164.htm.

3.2

MASONRY WALLS

ESSENTIAL KNOWLEDGE

Brick and masonry unit walls may have steel reinforcing bars that extend from the footing up into the body of the wall. Rough or uncut stone walls are usually laid up with mortar only. Dry stackwalls use no mortar at all. These walls occur over much of the Eastern U.S., and often appear to be little more than a running pile of rocks separating pasture from woodlands.

Impact collisions with a masonry wall can cause anything from minor surface dents to the collapse of the entire wall section. Even if the wall has not been damaged outside, it can crumble from within. If the mortar or concrete is poorly mixed, it can break down and material can begin to crumble. Occasionally brick or block will deteriorate from acid rain or poor material construction.

Masonry retaining walls can be made of stone, poured-in-place and reinforced concrete, or reinforced brick. A newer type of retaining wall made with interlocking concrete blocks can be laid up without mortar or specialized skills. These walls can go to great heights because they are engineered with plas-

tic wire basket structures, called geogrids, that attach to the block at calculated intervals to give the wall an effective width of 4' to 6' or more. Retaining walls are commonly found on properties with sloping yards or on hilly sites that require level ground. Because they can provide support for a level ground surface, they help to slow down surface runoff and help control erosion. The wider the wall, the greater resistance it has to sliding and overturning.

Retaining walls often fail when the soil behind the wall holds back too much water, making the lateral soil load much greater. More often, they fail from the expansive forces of freezing water trapped behind the wall. This lateral load causes cracking and, eventually, wall failure. Holes or drain pipes placed in the wall to relieve water build-up often silt up from fine particles leached from the soil above and become ineffective. Repairing retaining walls may entail altering the soil as well as making structural improvements to the wall.

A hybrid fence/wall system made of precast concrete is available as either fence or wall. It is offered as a fence as an open split rail system made of concrete, or a weight bearing 1 3/4"-thick wall. The walls are built by setting notched concrete posts into concrete footings and sliding 8" interlocking-panel sections on top of one another until the desired wall height is achieved. Cast into molds with finishes that resemble rough sawn wood planks or brick panels, this reinforced precast concrete system needs virtually no maintenance.

TECHNIQUES, MATERIALS, TOOLS

1. REPOINT EXISTING MASONRY WALL.

As the mortar weakens in old masonry walls it begins to crumble and fall out of the joints. This problem is typical in construction before 1930, as the mortar then used was a lime putty. Water aids the lime in leaching out of the mortar and the mortar crumbles as it loses strength. To test existing mortar, poke an ice pick into the joint. If the joint starts to crumble or the mortar appears to be sandy, repointing may be necessary. Clean out the old mortar joints with a chisel, being careful not to damage the brick or stonework. Make sure all of the crumbling mortar is removed until solid mortar is found. Remove all loose pieces and use a hose with pressure nozzle to clean out the joints. Repoint the joints with the same mortar type, unless the old mortar was of the lime based type. In that case, use lime putty but use 20% Portland cement in the mortar mix. The color can be adjusted by adding colored sand. After mixing the mortar, place it on a flat board. Using a joint filler, push the mortar from the board into the clean, wet joint. After the mortar has stiffened, use a jointer as a shaping tool to match the old joint profiles.

If a brick has come loose from the mortar, chisel out all of the mortar around the brick. To remove the brick it may be split with a chisel or a brick set. If necessary, trim the new brick (possibly 3/4") so it will fit into the hole. Apply mortar into the clean void and then push the brick in. Scrape away excess mortar and repoint gaps in the joint. Smooth the joint profiles with a jointer. (If the wall is to be pressure washed, do so before repointing the joints.)

ADVANTAGES: Repointing old joints provides a more uniform appearance and prevents moisture from entering the wall.

DISADVANTAGES: Repointing an entire brick wall face can be labor intensive. May be easier to repoint only the joints that are crumbling, then apply a sealer or stucco over the face to prevent moisture from entering the wall.

2. RESURFACE AN EXISTING MASONRY WALL.

To repair a crack in a reinforced concrete wall, clean out the break with a cold or brick chisel. Cut away crumbling mortar until hard concrete is reached. Mix the concrete mortar to a thick consistency. Wet the crack and fill it with mortar mix, then smooth the surface with a trowel.

To repair a hole, apply the first scratch coat eight to nine days before the final coat. Attach a new wire lath over the damaged area to any existing lath. After wetting the area, apply a scratch coat from 3/8" to 1/2" thick, with most of the stucco behind the lath. When the area begins to dry, score the scratch coat horizontally with a rake-like scarifier tool. After scratching the scratch coat, keep the area damp for 48

hours. Apply a second layer that comes within 1/8" of the final surface and keep the area damp for another 48 hours. Let the area cure for four to five more days. Dampen the area and apply the finish coat, with a pigment if desired. It is important to keep the finish coat damp for two days after application.

For scaling of depths to 3/4", you should use a special repair mortar and a sealer. For scaling depths up to 1 3/4" or 6" in diameter, use a bonding bridge, special repair mortar and a sealer. Clean crack with a wire brush. Chip out a V-shaped groove at the crack line and dampen the area. Patch with three parts fine sand to one part cement. Keep area damp for 48 hours. There are stuccos made for resurfacing masonry that are readily available at masonry stores. If sealing a brick face wall, use a silicone sealer that allows water vapor trapped in the brick to escape. Apply when the temperature is over 50° F and the wall has been dry for at least seven days. After spraying the sealer onto the wall, smooth out any runs with a brush.

ADVANTAGES: Repairing only the damaged parts of a wall is less labor intensive and less costly.

DISADVANTAGES: If the wall has some scaling problems, it is best to resurface the entire wall.

3. REPLACE PARTS OF EXISTING MASONRY WALL.

If stones, bricks, blocks, or mortar are falling out of the wall, it may be shifting due to the additional weight, water in the soil, poor drainage, or ground movement. Clean out the old mortar joints with a chisel, being careful not to damage the solid areas. Remove all crumbling mortar and loose pieces, and then flush with a water hose. Fill large voids inside the wall with chunks of rock or stone. If bricks, blocks, or stones are loose from the old mortar, they should be reset into the new mortar. Pieces of asphalt expansion strips or fiberglass insulation can also be used. The edges of the filler material should be recessed from the surface of the wall for the new mortar. Mix the cement to a thick consistency. Mist the area to be repaired with water. Pack the mortar tight into the joint and smooth the surface of the joint for water drainage.

ADVANTAGES: Repairing only the damaged parts of a wall is less labor intensive and less costly.

DISADVANTAGES: The problem of the wall damage should be fully addressed before repairs.

4. GOOD RETAINING WALL DRAINAGE.

Retaining walls should have weep holes to prevent damage from moisture building up behind the wall. When rebuilding a brick, block, or stone wall, leave some of the vertical joints in the first course unmortared as weep holes. For an existing wall, drill 2" weep holes into the bottom of the wall just above grade every 2' to 3', and line them with plastic tubing, such as a piece of hose. If possible, backfill behind the wall with gravel or crushed stone for better drainage. If the wall has no weep holes and it is not possible to bore through the walls, dig out the earth behind the wall and install a french drain. Geotextile fabric around a perforated drain-pipe behind the wall will promote water flow from around the wall. In addition, storm drains may be needed at the upper level of the retaining wall to help surface water to drain away from wall instead of flowing down behind it. Place the covered perforated drain in a layer of crushed rock, gravel, or free-draining river sand. The perforated pipe needs to be pitched 1/4" per foot in the gravel trench.

ADVANTAGES: Good drainage can extend the life of the wall.

DISADVANTAGES: May be very difficult to excavate behind the wall to install a drainage pipe and trench.

5. REPAIR A MASONRY RETAINING WALL.

Since retaining walls most often fail due to unseen forces, repair techniques will vary. In most cases of structural failure the wall needs to be excavated for some, if not all, of its distance. If physical inspection reveals that back-filled material is similar to surrounding poor-draining soil, then this soil should be removed. The wall's specific engineering requirements should be determined by a qualified designer/engineer. If the wall is salvageable, repair will be completed prior to the replacement of new granular back-fill, drain pipe, and filter fabric.

ADVANTAGES: May be cheaper than rebuilding if the existing wall can be reused. May have less impact on trees and plants than constructing a new wall.

DISADVANTAGES: Existing saved portions may have unseen defects. Could be more costly if some work has to be redone after placement.

6. REPLACE A MASONRY RETAINING WALL.

If a masonry retaining wall is failing beyond repair, consider rebuilding the wall completely. If the new wall is similar to the existing wall, site excavation work should be less costly than if an entirely new wall were built. A good retaining wall permits surface water to drain away slowly. Once the wall is built, it is back-filled with draining gravel material 2' to 3' out from wall up to within 6" of final grade. A layer of filter fabric should be placed between the gravel and the native soil, with a drain pipe at the bottom of the gravel backfill to permit easy drainage of water away from wall. This drain pipe may also be filter wrapped to inhibit silt blockage.

In colder climates the earth may be protected from freezing by placing a 2" layer of rigid polystyrene against the inside face of the foundation wall to keep the earth's natural warmth from being lost to the cold face of the exposed wall (and should reduce the likelihood of damage from the freeze/thaw cycle).

ADVANTAGES: A new wall will last indefinitely if properly constructed and maintained.

DISADVANTAGES: Can be very costly; shrubs and trees may be lost.

FURTHER READING

Build Your Own Walls and Fences, Penny Swift and Janek Szymanowski, New Holland Publishers, distributed by Sterling Publishing Co., New York, NY, 1997.

Concrete Masonry Handbook for Architects, Engineers, Builders, Portland Cement Association (PCA), Skokie, IL 60077; 800-868-6733 or 847-966-6200; <http://www.portcement.org/concrete.htm>, 1991.

Foundations and Masonry, National Concrete Masonry Association, Herndon, VA 20171; 703-713-1900; <http://www.ncma.org/>.

Guide to Concrete Masonry Residential Construction in High-Wind Areas, Portland Cement Association (PCA), Skokie, IL 60077; 800-868-6733 or 847-966-6200; <http://www.portcement.org/concrete.htm>, 1997.

Home Improvement/Home Repair, Richard V. Nunn, Upper Saddle River, NJ: Creative Homeowner Press, 1980.

Home Masonry Repairs & Projects, Black and Decker Home Improvement Library, Creative Publishing International, Minnetonka MN 55343; 800-328-0590 or 612-936-4700; 1996; <http://www.ConcreteNetwork.com/bookstore/concrete.htm>.

"The Keys to Historic Masonry Restoration," *Building Design & Construction*, February 1, 1997.

Ortho's Home Improvement Encyclopedia, The Solaris Group, San Ramon, CA, 1994.

Recommended Practices for Laying Concrete Block, Portland Cement Association (PCA), Skokie, IL 60077; 800-868-6733 or 847-966-6200; <http://www.portcement.org/concrete.htm>, 1993.

Segmental Retaining Wall Installation Guide, National Concrete Masonry Association, Herndon, VA 20171, 703-713-1900; <http://www.ncma.org/>.

PRODUCT INFORMATION

AboCrete (fills cracks, anchors posts and railings, structural patching, resurfacing and restoration. It has no solvents or volatiles), AboWeld 55-1 (rebuild broken risers, corners or treads in stairs), Abatron, Inc., Kenosha, WI 53144; 800-445-1754 or 414-653-2000, www.abatron.com.

Armorloc (interlocking concrete blocks and concrete erosion control systems), Armortec, Bowling Green, KY 42102, 502-781-9813; <http://www.Amortec.com>.

Ashford Formula (concrete, stone and masonry sealer), Springville, UT 84663, 801-489-5663; www.ashfordformula.com.

Bestmann Green Systems, Inc.; Salem, MA 01970; 978-921-1300; www.bestmann.com.

Cherokee Sanford Brick Co., Sanford, NC 27330; 800-277-2700.

Crumpler Plastic Pipe, Inc. (corrugated plastic culverts, and drain pipes), Roseboro, NC 28382, 800-334-5071; <http://www.cpp-pipe.com>.

Cunningham Brick Co., Inc., Lexington, NC 27292; 800-672-6181.

Doublewall Corporation (gravity wall systems), Plainville, CT 06062; 860-793-0295.

Duogard II (low-VOC water emulsion concrete form release), VOCOMP-20 (low-VOC water emulsion acrylic curing and sealing compound), W.R. Meadows, Inc., Elgin, IL; 708-683-4500.

GEOBLOCK (50% post-consumer recycled plastic porous pavement system with interlocking grids), GEOWEB (engineered HDPE, expanded honeycomb-like matrix that is filled with earth to provide stable retaining wall systems with variable slope), Presto Products, Appleton, WI 54913; 800-548-3424 or 414-739-9471.

GeoStone (segmental retaining walls that do not need mortar or concrete footing, uses clip system of earth reinforcement), GeoStone (Division of Grasselli Concrete Products), Midfield, AL 35228; 205-925-3617; www.geostone.com.

Grasscrete (porous paving system used for driveways), Custom Rock Concrete Wall System (flexible liner system used to achieve a look of a stone wall), Bomanite Corp., Madera, CA 93639; 800-854-2094 or 209-673-2411; www.bomanite.com and www.custom-rock.com.

Grasspave2 (manufactured from 100% recycled HDPE for porous paving applications) and Gravelpave2 (porous geotextile filter fabric backing to hold small aggregate particles in place, for gravel fill instead of sand and turf), Invisible Structures, Inc., Aurora, CO 80011, 800-233-1510 or 303-373-1234; <http://www.invisiblestructures.com/>

Keystone Retaining Wall Systems Inc., Minneapolis, MN 55435, 800-891-9791 or 612-897-1040; <http://www.keystonewalls.com/>.

Stonhard, Dex-O-Tex (Low-VOC epoxies that can be applied in patterns like terrazzo), IsoSet (water-based adhesives), Ashland Specialty Polymers & Adhesives Division, Columbus, OH 43216, 614-790-3333; www.ashchem.com.

TIRECRETE (wire-mesh reinforced porous exterior rubber surfacing for roadways and driveways made from 50% recycled tires), Surfacing Concepts, Inc.; Clair Shores, MI 48081; 810-776-5560; Mt. Clemens, MI, 48046; 810-463-7597.

Versa-Lok Retaining Wall Systems, R.I. Lampus Co., Springdale, PA 15144; 412-362-3800; 800-872-7310; www.lampus.com.

4

UNDERGROUND CONSTRUCTION

4.1

WELLS

ESSENTIAL KNOWLEDGE

A drilled well consists of a hole bored into the ground, with the upper part lined with casing that prevents the collapse of the borehole walls and prevents surface or subsurface contaminants from entering the water supply. It also provides a housing for a pumping mechanism and for the pipe that moves water from the pump to the surface. The casing should have a drive shoe attached to the bottom to prevent damage during well driving. Below the casing is an intake through which water enters the well. This may be an open hole in solid bedrock or screened and gravel-packed, depending upon the geologic conditions. After drilling, it is necessary to remove fine material remaining from the drilling process so that water can more readily enter the well by using compressed air (blowing), bailing, jetting, surging, or pumping. After proper disinfection, the well is capped, and has an air vent, to provide sanitary protection until it is hooked into the house's plumbing system. Inspection of the well should reveal causes of poor water quality and restricted water flow.

TECHNIQUES, MATERIALS, TOOLS

1. REMEDY POOR QUALITY WATER.

If water quality is poor, revealed either by taste or testing, the water can be sealed off from the surrounding soil. One method is to install an additional casing inside the original casing and grout into place. If the water quality remains unsatisfactory, or if original well construction defects cannot be remedied, the well may need to be abandoned. It must be completely sealed prior to drilling a new well, in order to prevent cross-contamination between sites.

ADVANTAGES: Installing additional casing may be more cost effective than drilling another well.

DISADVANTAGES: Adding another casing inside the well may not solve the problem if the water supply itself is contaminated.

2. REMEDY IMPROPERLY SIZED WELL.

A well too small may lead to water usage problems, such as poor or limited simultaneous use of sink and washer. Well size should be based on peak demand. A day's use may be concentrated into a period of one to two hours, often in different areas of the house at the same time (laundry, bathroom, and lawn). A conservative estimate is that a home will need 3 to 10 gallons per minute to meet all the needs of two to four people. If the water supply is insufficient, another well may need to be drilled in a different location.

ADVANTAGES: Drilling an additional well lets each well alternate so as not to deplete the water sources.

DISADVANTAGES: Can be costly.

3. PLUG ABANDONED WELLS AND BOREHOLES NEAR DRINKING WELL.

Potential ground water contamination sources are abandoned wells and boreholes that penetrate aquifers or breach a zone that is a barrier to contaminant migration. Cross contamination can occur in abandoned wells or boreholes when two or more aquifers are penetrated and a seal has not been placed or is no longer intact between the zones to prevent the water from mixing. The potential for direct ground water

contamination exists in abandoned wells and boreholes along the borehole if an adequate surface seal was not installed or has deteriorated. Using a geotechnical fabric around the outside of the abandoned well will keep fine particles out. Another method is to fill unused or “dry” wells with cement grout, bentonite chips, or native soil. Most local codes allow any person to abandon a well, but it is recommended that a registered well driller do the work.

ADVANTAGES: Installing a filter around the abandoned well will only work for awhile; filling and plugging the well will keep it from cross contaminating nearby drinking wells.

DISADVANTAGES: The majority of states have regulations specifying decommissioning (plugging) methods for abandoned water wells or boreholes; check local codes.

FURTHER READING

Builder's Guide to Wells and Septic Systems, R. Dodge Woodson, New York: McGraw-Hill, 1997.

Finding Water: A Guide to the Construction and Maintenance of Private Water Supplies, 2nd edition, Rick Brassington, New York: John Wiley & Sons, 1995.

Wells and Septic Systems, 2nd edition, Max and Charlotte Alth, S. Blackwell Duncan (contributor), Tab Books, 1991.

4.2

ON-SITE WASTE WATER TREATMENT

ESSENTIAL KNOWLEDGE

On-site waste-water treatment is usually provided by cesspools, septic systems, or aerobic treatment units. Cesspools, drywells, or seepage pits (Fig. 1) are the oldest forms of on-site sewerage systems, often still in use in older homes. They are simply a single hole in the ground loosely blocked up with locally available materials (stone, brick, block, or railroad ties) and capped either with ties covered with a layer of old steel roofing or a cast-in-place concrete lid with a cleanout hole near the center. Household waste water enters the cesspool and the liquid portion is absorbed into the ground. When the soil plugged, a new cesspool was added. Sometimes installers placed an elbow or a tee in the outlet pipe from the first cesspool, creating a baffle to hold back the floating greases and scums. The first tank is pumped out to maintain system operation.

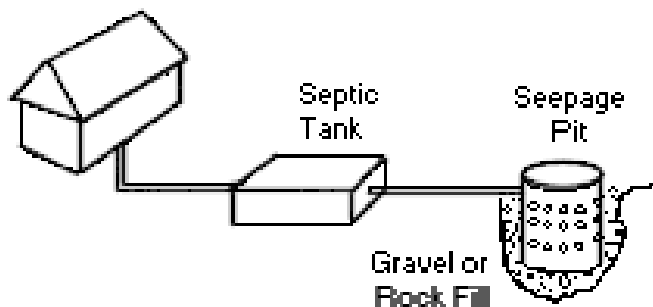

FIGURE 1

SEEPAGE PIT SYSTEM

A septic system's main components (Fig. 2) are a water-tight chamber that all household wastewater enters for settling and anaerobic digestion of greases and solids; a distribution box; drainage tile; and a drainage or leaching field to dissipate the waste. Older septic tanks were made of asphalt-coated steel, while today tanks are of concrete, fiberglass, or plastic, with a set of baffles. Most tanks have an inspection hatch at both the inlet and the outlet. Some have a third hatch in between for pumping access. Steel tanks often have one round lid that covers the entire tank. Access locations should be recorded and/or marked.

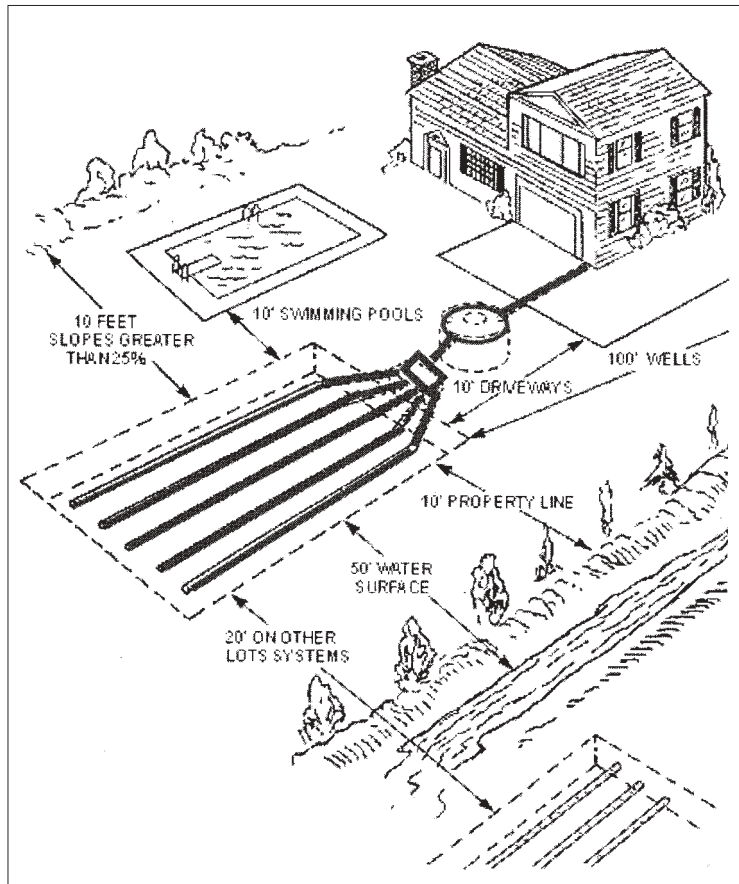

FIGURE 2 SETBACKS FOR SEPTIC SYSTEM

Septic tanks should be pumped approximately every three years of normal operation. They should not be treated with any additives and should be protected from harmful chemicals used in many homes, which can inhibit the anaerobic process. Septic systems can usually last 15 to 40 years or longer, depending on their design and maintenance. For example, even a relatively new system can fail if it is located in poor soil, undersized, or is not properly installed or maintained. If soil or site conditions are not suitable for a conventional drainfield, an alternative system might be used.

In aerobic treatment systems, waste water is mixed with air, promoting bacterial digestion of organic wastes and pathogens. The biological breakdown of wastes in a septic tank's anaerobic (oxygen-deprived) environment is relatively slow. Aerobic units are more expensive and require significantly more maintenance than conventional septic systems. However, they provide good wastewater treatment on homesites that are otherwise unsuitable for development because the soil type, depth, or area is inadequate for on-site treatment. The effluent from an aerobic unit can be discharged into a soil absorption system.

The exact locations of system components are not obvious, because they are below ground. If the location of the system is not in the home's records, check with a pumper's records or the County's Environmental Health Division. If no record of location exists, in the basement look for the sewerpipe leav-

ing the house and note the direction in which it goes through the wall. In houses without basements, go to the outside of the house, along the wall closest to the lowest bathroom. Outside, probe with a steel rod by gently tapping into the ground, starting 5' from where the sanitary sewer leaves the house, or dig 10' to 20' away from the house in the direction of the house sewer line. The septic tank is usually within 2' of the ground surface. The distribution box and drainfield are usually located downslope from the septic tank. In some cases, wastewater is pumped to a drainfield uphill from the septic tank. Check with the state's septic design standards on slopes (greater than 15% are common) that are unacceptable.

To prevent contamination of water supplies, the drainfield should be at least 100' from any wetland, shoreline, stream bed, or drinking water well (check with local building officials). A well is better protected if the system is downhill from it.

TECHNIQUES, MATERIALS, TOOLS

1. REPAIR THE SEPTIC SYSTEM.

If the septic system appears to be blocked, check the washing machine outlet, floor drain, bathtub, or remove the cleanout plug very carefully to avoid a flood to see if there is water backed up through any of the drains which are below the level of a toilet. If no water is backed up then the problem is likely with a toilet or plumbing. Tree roots are a common cause of blockage. If roots are blocking one or more pipes, the roots should be cut out and the joints sealed where roots entered the pipe. Settling, breaking, crushing, and pulling apart are problems due to poor installation. Freezing, plugging at joints, corrosion, or decomposition are other sources of blockage. Insulating, replacing, releveling the pipes, sealing joints, and properly backfilling will resolve most problems. Failed drywells can sometimes be excavated and repacked with crushed stone to create a new soil surface for absorption.

ADVANTAGES: Repairing a system is far less costly than installing a new one.

DISADVANTAGES: Depending on the problem, repairs can be costly.

2. PUMP OUT THE SEPTIC SYSTEM.

Regular pumping of the septic tank (Fig. 3) is the most important factor in system maintenance. As more solids accumulate in the tank, particles are more likely to flow out of the tank and into the drainfield. The septic tank needs to be pumped if: the sum of the solid layers (sludge plus scum) takes up more than half of the tank capacity; the top of the sludge layer is less than 1' below the outlet baffle or tee; or the bottom of the scum layer is within 3" of the bottom of the outlet baffle (or top of the outlet tee). Most septic tanks need to be pumped every three to five years, depending on the tank size, and the amount and type of solids entering the tank. This should be done by a septic system maintenance company.

ADVANTAGES: The cost of pumping a septic tank (\$250 to \$300) is far less than the expense of replacing a drainfield clogged by escaping solids (\$3,000 to \$12,000, depending on site conditions, the size of the home, and the type of system).

DISADVANTAGES: May not fix the problem.

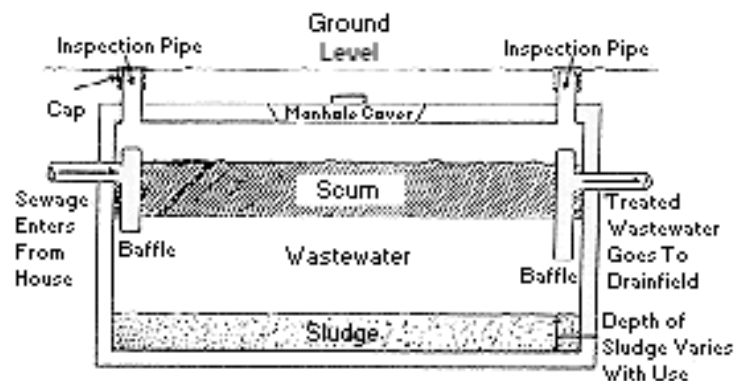

FIGURE 3

SEPTIC TANK COMPONENTS

3. REJUVENATE THE LEACHING FIELD.

A leaching field that is compacted or plugged will fill up with effluent and cause the system to fail. Instead of installing a new system, the leaching field soil can be “fractured” through a process called “terra-lifting.” A hollow tube is pushed into the soil, which is then pumped full of air, creating fissures in the soil. The fissures will permit the leaching field to drain and aerobic bacteria to flourish. A leaching field can be treated through terra-lifting in a few hours, depending on size.

ADVANTAGES: Quick, relatively low-cost solution. Does not require digging.

DISADVANTAGES: May not remedy problem if blockage is extensive or leaching field is exhausted.

4. INSTALL A NEW SEPTIC SYSTEM.

Both the septic tank and drain field must be located according to setbacks from surrounding elements (Fig. 2) and designed for the maximum occupancy of the home and have adequate capacity to treat all the wastewater generated in your house, even at times of peak use. Installing low-flow toilets and water-saving faucets (see *Volume 6: Kitchens & Baths*) will reduce the size of the system needed. Each state sets procedures for calculating wastewater flow and sizing on-site treatment systems. There are various rules of thumb for calculating the volume of wastewater from a single-family home: 100 to 200 gallons per bedroom per day multiplied by the number of bedrooms in the home; or 75 gallons per person per day. The septic tank should be large enough to hold two days’ worth of wastewater, as this is long enough to allow solids to settle out by gravity. The addition of a bathroom, bedroom, or water-using appliance (such as a Jacuzzi, dishwasher, or water softener) to the home may require expanding your system. Typically, a new three-bedroom home is equipped with a 1,000 gallon tank. A two-compartment tank or a second tank in series can improve sludge and scum removal and help prevent drainfield clogging (Fig. 5).

ADVANTAGES: A new system is more efficient and will alleviate problems with old systems if properly designed and installed.

DISADVANTAGES: Lot size may not support the installation of a new system; can be costly depending on design, size, and other constraints.



FIGURE 4

DRAINFIELD INSTALLATION

FURTHER READING

The Septic System Owner's Manual, Lloyd Kahn, Blair Allen, Jullie Jones, and Peter Aschwanden. Bolinas, California: Shelter Publications, 1999.

Septic System Owner's Guide (#PC-6583-OF2), University of Minnesota Extension Service, 800-876-8636.

PRODUCT INFORMATION

Infiltrator Systems Inc., 4 Business Park Road, P.O. Box 768, Old Saybrook, CT 06475; 888-887-4523; 860-388-6810; email: info@infiltratorsystems.com.

K-87 Soap Digester Sewage System Treatment, K-67 Bacterial Drain and Trap Cleaner, K-57 Septic Tank and Cesspool Cleaner from Roebic Laboratories, Inc.; 203-795-1283; www.roebic.com.

Orenco Systems, Inc., 814 Airway Avenue, Sutherlin, Oregon 97479; 800-348-9843 or 541-459-4449; fax: 541-459-2884; email: info@orencocom.com.

Septic Protector, 14622 268th Ave., Zimmerman, MN 55398; 888-873-6504; 612-856-3800; www.septic-protector.com.

Terralift International, Inc., 104 E. Main Street, Box 532, Stockbridge MA 01262; 413-298-4272; fax: 413-298-3481; www.teraliftinternational.com.

4.3

WATER AND SEWER LINES

ESSENTIAL KNOWLEDGE

Water lines must be in good repair to deliver water without risk of contamination. Sewer lines must carry waste out of the house without risk of contamination to the soil or water outside the home. Water supply lines usually deliver water at pressures that range from as low as 15 psi up to 120 psi. To help prevent them from freezing, municipal water and well-water supply lines are buried in trenches at or below the frost line. In older homes supply lines may be 3/4" to 1" galvanized or copper pipe or (in very old homes) lead. In houses constructed since the 1970s, supply lines are in the range of 1" to 2" copper or polyethylene coiled pipe suitable for burying and approved for drinking water.

In-ground supply pipes seldom need purging. If problems occur with water quantity or pressure, the pipe may be leaking or it may be clogged with sedimentation or scale. If water pressure drops at sinks and showers, and no leaks are evident in the house, it could be caused by a leaking supply pipe. If the water meter is outside the house there could be a leak from the meter to the house. If the first few feet of water supply line can be unearthed and inspected, the remedy may be apparent. Old, small, heavily scaled pipe may suggest that replacement is in order. If the pipe does not look decrepit, spot repair may be sufficient. Accessing and replacing water lines is often complicated by surface paving, walls, trees and other obstructions and these obstacles can greatly affect construction costs. Unfortunately, fixing pipes with poor water pressure or tainted water may require digging up the entire line.

Sewer lines run from the house to public sewers or private septic systems. Because the pipe carries wastes that come from within the house, sewer lines do not need to run below the frost line. Slow draining waste could mean pipe restriction due to internal clogging, roots, or a damaged line. Problems with sewer lines can be assessed with snakes to check for blocks; some professionals use snakes with cameras that offer video images within the pipe. Most sewer pipe failure results from ground settlement caused by improper backfilling or, in rare cases, ground settlement.

TECHNIQUES, MATERIALS, TOOLS

1. REPAIR THE WATER LINE.

If a leak is detected, once it is located and fixed water pressure should improve in the house. Follow pipe supplier's recommendations and local plumbing regulations for repairing the type of water pipe found. Avoid low-cost repair strategies that are not cost effective when considering the cost to dig up pipe. After pipe repair, care should be taken to properly backfill below and above the pipe with non-settling material to assure proper pipe support under ground.

ADVANTAGES: Repairing only damaged sections of pipe can save time and money; if leaks can be detected, extensive excavation can be avoided. Less disruption to surrounding grounds.

DISADVANTAGES: All problem sections of the pipe may not be uncovered. Fixing a section of the pipe will not solve system-wide problems, such as defective joints or pipe deterioration.

2. REPLACE THE WATER LINE.

If the water line is of questionable condition, and extensive landscaping is planned, it may make sense to remove and replace the entire line. When replacing supply lines, care should be taken to provide adequate bearing support by placing gravel into the trench before laying new pipe and replacing soil. If supply pipe runs are more than a few lengths, polyethylene tubing may be most cost effective, as it is available in 200' coiled lengths. Lines can also be replaced using a "trenchless" method that does not require excavation. A hardened steel splitting head is pulled through the old pipe. A new pipe is attached to the back of the splitting head (Fig. 5) and follows the path of the old line.

ADVANTAGES: Restores supply lines to new condition and longest useful life. Best solution when overall pipe condition is suspect.

DISADVANTAGES: Can be costly and inconvenient; loss of desirable surface landscaping is possible.



FIGURE 5

TRENCHLESS SPLITTING HEAD

3. REPAIR THE SEWER LINE.

Unlike water lines, sewer lines can be snaked to locate problems. Because sewer lines regularly carry warm water from the house, they are usually found only a few feet from the surface of the earth, and are thus easier to find. Poor flowing sewer pipes can be clogged with roots or non-dissolving household waste. Sewer snakes, power snakes or roto-rooting can unclog lines, though the condition may return if the source of the problem is not corrected. Once a clogged or broken line is located, the line should be excavated back to sound, undamaged pipe where a new section can be spliced in cleanly. Older homes will have 4" cast iron sewer lines. Newer homes will have PVC schedule SDR 35 plastic pipe. In either case, the replacement pipe will be the PVC 35 and the joint can be made using a Fernco soft coupling, which can join same or similar pipe of roughly the same diameter. These joints should last as long as the pipe and permit splicing old to new, even of different materials. Once repairs are complete, the trench should be backfilled with gravel or similar material to assure stability.

ADVANTAGES: Since sewer lines will usually last many years without degradation, fixing a part of the line should return the line to dependable, like-new condition (if the cause of the problem is also fixed). Minimizes disruption to property. Conserves materials and cost.

DISADVANTAGES: Care must be taken with repair work; must be back-filled properly.

4. REPLACE THE SEWER LINE.

Replacing sewer lines involves essentially the same processes as repair. In addition to digging a new trench and backfilling with good bearing material, care needs to be given to maintain a slope of 1/8" per foot from the house to the outlet elevation in the street. New lines should be made with 4" round PVC schedule SDR 35 pipe, which comes in 13' lengths. The pipe is joined together by a hub and gasket system that snaps together to form a permanent joint without special tools.

ADVANTAGES: Best approach if a large addition or other site excavation requires disturbing an existing sewer line; long-term solution.

DISADVANTAGES: Full replacement can be disruptive to existing property; could threaten the health of trees and shrubs in the vicinity.

FURTHER READING

Septic Tank/Absorption Field Systems: A Homeowner's Guide to Installation and Maintenance, <http://muextension.missouri.edu/xplor/waterq/wq0401.htm>

Trenchless Technology Magazine, 1770 Main Street, P.O. Box 190, Peninsula, OH 44264; 330-467-7588; fax: 330-468-2289; www.ttmag.com.

PRODUCT INFORMATION

AAA Trenchless, 800-922-2458, 916-325-9992, fax: 916-448-3952.

American Leak Detection, 888 Research Drive, Suite 100, PalmSprings, CA 92262; 800-755-6697; fax: 760-320-1288.

4.4

UNDERGROUND STORAGE TANKS

ESSENTIAL KNOWLEDGE

Underground storage tanks are commonly used for home heating oil. It is recommended that buried tanks be tested, which typically costs about \$500. Specialists and some oil companies have equipment to test buried tanks for leaks. Both simple pressure-testing and sophisticated electronic testing are used on residential tanks. Periodic tank testing for a small, buried residential tank is typically less cost effective than tank relocation.

Testing for water in the tank is simple and can be done by any service person using a simple chemical paste on a probe. A lot of water in the tank may indicate leaks. Underground fuel storage tanks usually fail from rust perforation due to several effects of water inside the tank including, in the case of heating oil, the combination of water with sulphur in the fuel. External rust, unless very heavy, is not highly correlated with internal rust. There are also mandatory requirements for abandoning buried old and unused tanks.

TECHNIQUES, MATERIALS, TOOLS

REMOVE/ABANDON AN UNDERGROUND TANK.

If a tank is not to be used, or testing indicates a leaking tank, it should be removed or abandoned. Proper abandonment procedures involve pumping out remaining fuel, confirming that there has been no leakage, and filling the tank with an approved filler or removing it entirely. One should check local building codes for regulations and methods of proper removal (Fig. 6) of an underground storage tank. It should be replaced with a double-walled or above-ground tank.

ADVANTAGES: Eliminates problems with leaky, unsafe tanks. Removing a tank allows certification that tank was not leaking, mitigating future claims against the property owner and negative impacts on resale value. **DISADVANTAGES:** Can be costly to remove and replace, depending on size, location, and soil contamination (if any).



FIGURE 6

TANK REMOVAL

FURTHER READING

“Homeowners Guide to Fuel Storage,” *Agway Energy Products*, Verbank, NY, November 1990.

PRODUCT INFORMATION

Advanced Environmental, 11 Virginia Road, White Plains, NY10603; 914-761-8020;
www.thetankspecialists.com.

Northeast Environmental, Inc., 221 Stanley Avenue, Suite B, Mamaroneck, NY 10543; 877-574-TANK; 914-777-1930; fax: 914-777-1928; www.northeastenvironmental.com.

5

LANDSCAPING

5.1

LANDSCAPE CARE

ESSENTIAL KNOWLEDGE

Trees and plants add beauty to a home and also help regulate and replenish the natural environment. Healthy growing plants and trees (Fig. 1) improve air quality by scrubbing out dust and increasing oxygen levels. Over time, soil conditions can be improved by mulching and composting plant material that is generated by trees, lawns, and gardens. Trees and plants are also a soil binder that prevents soil erosion. Water quality is protected when runoff is moderated and water that percolates through soil into aquifers is cleaned. Water that is filtered by leaves and foliage has some of its impurities scrubbed out.

Planted too close to buildings (Fig. 2), trees may cause foundation damage from roots that can cause cracks or wall failure. Overhanging limbs may fall and damage roofs or cause gutters to clog from twigs and leaves that can block water drainage. Foundation plantings may promote mold and fungus growth on siding that is shrouded from the sun by dense evergreen branches.

Buildings can reduce the amount of nutrients available to plants, so trees especially need to be properly sized and located to assure health. Trees and shrubs may have been planted too close to other plants or objects and if they are still healthy, they may be transplanted to a more suitable location. Feeding plants and trees can improve plant vitality and pruning may also help by reducing the nutrient load required by the tree. If possible, a licensed arborist should be consulted for specific recommendations for each tree/plant species being disturbed. Large trees that are damaged or require trimming of higher branches require an experienced tree service (Fig. 3). Properly planted and nourished, most shrubs and trees will not require constant maintenance.



FIGURE 1

HEALTHY PLANTINGS

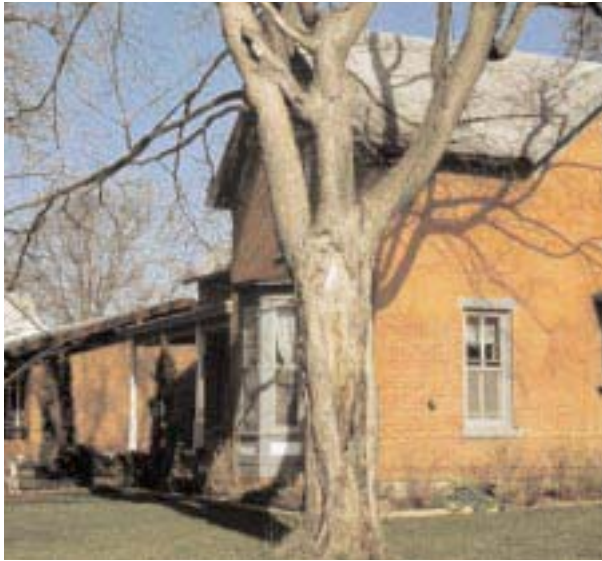

FIGURE 2

TREE TOO CLOSE TO HOUSE



FIGURE 3

TRIMMING HIGH LIMBS

Trees have root systems that usually extend far beyond the drip edge of branches. This makes roots very susceptible to damage from trenching or excavation. Where possible utility lines should be tunneled under trees rather than trenched through.

When the natural slope of yards and gardens is changed intentionally, it can result in softer or steeper grades achieved by regrading to desired effect. A berm may serve as a visual screen to block an noisy eyesore such as a highway, or help to slow or re-direct surface water runoff.

Berms and other open areas of a yard are often covered with turf grasses that are not native to the environment. Most ornamental lawn grasses contain mixes of Kentucky bluegrass that like alkaline soils and lots of moisture and sunlight. Since much of the continental US does not naturally have these conditions, keeping sod healthy and vigorous is an ongoing and costly endeavor requiring regular fertilizer, watering during dryspells, regular weeding, and cutting. Specialty lawn treatments are controversial because they use pesticides and chemicals, traces of which can be found in water and air. At certain levels these chemicals are known to be detrimental to the environment. The reader interested in more information about local lawn care should inquire directly to local providers and applicators who may have formulations specially designed for a specific area and who will know of applications that may be hazardous.

TECHNIQUES, MATERIALS, TOOLS

1. REPAIR TREES AND SHRUBS.

Tree and shrub growth can be stunted by reduced access to water or nutrients, which can cause the plants to lose leaves or entire limbs and branches. Restoration should be attempted in phases to see what works before trying alternative measures. After consulting local professionals or nurseries for advice, an approach might be applying recommended fertilizer to the root base of the tree or shrub. If plant malaise persists the following year, consider limb thinning using proper tools (Fig.4) or some other approach that is recommended by a local professional. This will reduce the nutrient load on the root system. Mature but sickly landscaping may require special applications that are unique to the species and site. In such cases, consultation with a landscape professional may be necessary to restore the plant to health.

ADVANTAGES: Appropriate action keeps plantings healthy.

DISADVANTAGES: Palliatives for plant distress or disease may delay inevitable new plant stock or improved landscape design. Money spent for repair/restoration may not be cost effective because it may mean less money is available for a later replacement phase.



FIGURE 4

PRUNING TOOLS

2. PROTECT TREES AND SHRUBS DURING CONSTRUCTION.

When building or remodeling around mature trees and shrubs it is necessary to take preventive steps to avoid harming healthy species to be preserved. The first step is to inventory what is worth saving and to prioritize which plants are more important. Flag important trees, branches, and shrubs before starting, and then hire a small-scale firm to do the digging (the excavator-operator of the small firm will likely be the same person who does the initial estimate and job appraisal and should remember the special care that was agreed upon for the job). Install a fence around building areas and also areas for parking and make the rest off limits.

Care should then be taken with digging in the vicinity of saved trees. In general, keep trenches at least 15' from the center of tree trunks or, if not possible, consider boring a tunnel directly under the trunk a few feet below the surface. Avoid raising or lowering the grade or even scraping the surface above tree and shrub roots or excessively treading over the earth. All these activities can weaken or kill the root system. Most root systems are within 18" of grade with large feeder roots permeating the top 6" of soil and these must be protected.

If construction will cut across roots, consider using piers instead of a continuous trench. When stockpiling soil, avoid piling onto root areas of saved trees. If unavoidable, consider using a tile aeration system so that oxygen is not cut off from root tops. When digging is required across tree root centers, dig from a radial position with a vertical chopping motion so that roots will be cut cleanly. Avoid ripping up lateral root structures, which could be affected by conventional digging. Broken roots should be neatly trimmed with a pruner or saw and kept from drying or freezing while excavation is open.

ADVANTAGES: Allows mature plantings to be retained.

DISADVANTAGES: Unless carefully protected, trees and shrubs could be lost.

3. REMOVE TREES OR SHRUBS.

Sometimes trees or shrubs must be removed. When cutting down trees, whenever possible avoid digging out the trunk. Dig down around the base of the tree and remove the portion of the stump that is above ground. Digging or grubbing out trunks can kill roots from other trees and shrubs in the area.

ADVANTAGES: Can extend the useful life of plant species. Is less disruptive and less costly than replacement.

DISADVANTAGES: Work can be extensive and costly.

4. REPLACE TREES OR SHRUBS.

When choosing to replace existing trees and shrubs that cannot be maintained or have become diseased or rotted, consider replacing successful species with the same species. If considering upgrading or altering the landscape with new vegetation, evaluate environmental factors such as soils, climate, slope and hydrology. Consider the effect the new trees will have on views, screening, shade, wildlife habitat, color, and scent (if any) new trees and shrubs will have.

When replacing trees or planting new specimens, always chose native species if possible. As first cost, they are usually cheaper to purchase than exotic species and will thrive in the environment without pesticides, fertilizers, or special watering, which makes them a best buy in life cycle costs too. Choose an exotic, non-native species only after concluding that you can provide the proper soil preparation and necessary additional maintenance that they will require.

ADVANTAGES: Affords the chance to solve long-term problems and make improvements that will be beneficial to the yard or landscape for years to come. Opportunity to replace non-native species with native species.

DISADVANTAGES: Replacing mature trees with well established nursery stock can be very expensive. Replacing with smaller, more affordable trees can leave property looking empty or disfigured. Requires patience for plants to develop into mature specimens.

5. INSTALL LIGHTNING PROTECTION FOR TREES.

According to the National Recreation Association, the ten species most likely to be struck by lightning are, in order: oak, elm, pine, tulip, poplar, ash, maple, sycamore, hemlock, and spruce. Since the expense of removing a large, lightning-struck tree may approach that of installing a lightning protection system, it is economically prudent to protect large or valuable trees from lightning strikes. In addition, protecting nearby trees from lightning helps protect the house itself, as electric current may otherwise travel through the tree to the house seeking a ground. If the house features lightning protection, it should share a common ground with the tree.

Similar to that for a building, lightning protection for a tree (Fig. 5) consists of these copper components: air terminal points (rods); down conductor cables; copper fasteners; and adequate grounding, usually 10' rods driven into the earth. Grounding is buried while terminals are positioned at high points and cables are installed along the trunk and main boughs with fasteners driven through the bark. Since specialized equipment is required, installation and testing should be performed by a professional lightning protection company to comply with Underwriters' Laboratories, National Fire Protection Association, and Lightning Protection Institute standards. The National Arborists Association is updating its own lightning protection standards for trees, which promises to be most comprehensive. For further information, refer to the section on "Lightning Protection" in *Volume 7: Electrical/Electronics*.

ADVANTAGES: Can protect large or prize trees from lightning damage. Does not harm tree.

DISADVANTAGES: Improperly installed or poorly grounded systems may not provide protection.

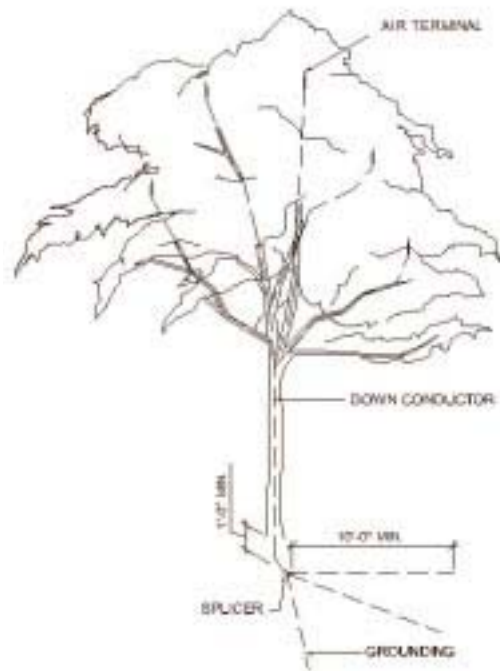

FIGURE 5 LIGHTNING PROTECTION FOR TREES

FURTHER READING

“How to Prune Trees,” U.S. Department of Agriculture Forest Service, http://willow.ncfes.umn.edu/ht_prune/prun001.htm.

“How to Recognize Hazardous Defects in Trees,” http://willow.ncfes.umn.edu/ht_haz/ht_haz.htm.

“Rx For Wounded Trees,” <http://willow.ncfes.umn.edu/pubs/misc/woundedtrees/rxwounded.htm>.

“Tree Care Tips & Most Frequently Asked Questions,” National Arborists Association, <http://www.natlarb.com/tips.htm>.

PRODUCT INFORMATION

A Climber's Guide to Hazard Trees, Amherst, NH: National Arborists Association.

Guide for Plant Appraisal, Council of Tree and Landscape Appraisers, Amherst, NH: National Arborists Association.

Pruning, Trimming, Repairing, Maintaining, and Removing Trees, and Cutting Brush — Safety Requirements (ANSI Z133.1-1994), New York: American National Standards Institute, 1994.

Tree, Shrub, and Other Woody Plant Maintenance — Standard Practices (ANSI A300-1995), New York: American National Standards Institute, 1995.

ENERGY-EFFICIENT AND SUSTAINABLE LANDSCAPING

ESSENTIAL KNOWLEDGE

In a variety of climates, trees and other plants can have great effect on house comfort in both summer and winter. Properly selected, trees can shade harsh summer sun and permit winter rays to shine into south-facing glass. Trees naturally aid in summer cooling by their photosynthesis: they absorb solar energy and store it as molecular bonds in wood fiber; they transpire water vapor which causes cooling as it evaporates; they provide shade and temperature differentials which promote breezes; and trees absorb carbon dioxide that would otherwise add to global warming. Trees and shrubs can also aid as wind shields where exposure to wind is a problem.

TECHNIQUES, MATERIALS, TOOLS

1. LOCATE TREES AND SHRUBS FOR SHADE.

In addition to awnings and covered porches, carefully placed trees and shrubs can keep a home much cooler in summer. Trees, shrubs, and vines all provide shade to moderate summer heat gain. Such plants also create a cool microclimate that can dramatically reduce the temperature by as much as 9° F in the surrounding area. During photosynthesis, large amounts of water vapor escape through leaves, cooling the passing air. The dark, coarse leaves absorb solar radiation. Deciduous trees (trees that lose their leaves each year) offer one of the best ways to cut solar gain, by shading roofs, walls, windows, and air conditioning units. Trees can reduce cooling loads by 20% to 40%. Deciduous trees also allow winter sun to penetrate and warm the house. The northeast-southeast and northwest-southwest sides of the home are the best locations for shade tree placement. In regions where it is hot year-round, trees can be planted to shade the southern exposures. Shrubs planted a few feet away from the house can provide extra shade without obstructing air currents. Vine trellises can shade windows or a wall of the house, and should be located away from the wall to allow air to circulate. Vegetation too close to the house can trap heat and make the air around the house even warmer.

ADVANTAGES: An effective way to promote energy conservation for homes through natural means.

DISADVANTAGES: It may take many years for trees and shrubs to reach an effective size.

2. LOCATE TREES AND SHRUBS AS WIND BUFFERS.

Trees and shrubs can be used to mitigate the effects of cold in the winter. Trees and bushes can buffer winds, mitigating cold air infiltration, which helps to lower heating costs. Evergreens, such as pine and spruce, should be densely planted for windbreaks, which can reduce wind speeds by 80%, over a distance equal to twice the height of the windbreak. Trees and shrubs can also be used to create loosely planted windbreaks that are more effective in cutting winds over greater distances. Loosely planted windbreaks, made up of conifers and deciduous trees, can slow wind speeds by 40% over a distance five times the height of the windbreak.

ADVANTAGES: An effective way to promote energy conservation for homes through natural means.

DISADVANTAGES: It may take many years for trees and shrubs to reach an effective size.

3. WATER PLANTS WITH CONSERVATION IN MIND.

Watering of trees, shrubs, and ground cover should take place in the early morning or the evening hours when temperatures are lower and winds are at a minimum to help reduce water loss due to evaporation. Water slowly for long periods of time (drip water is best) to encourage deep rooting. If possible, a drip irrigation system should be used. As a result, plants will have great reservoirs of soil area for drawing moisture and anchoring themselves. Avoid over-watering, as this will kill vegetation. Use moisture-conserving mulch, such as ground bark or other composted material, to cool soil and reduce evaporation.

ADVANTAGES: Conserves water; promotes healthy plants.

DISADVANTAGES: Drip irrigation systems can be costly.

4. PROMOTE SUSTAINABLE LANDSCAPING.

Landscape choices should be made that promote sustainability. For example, use low-maintenance, drought-resistant plants, shrubs, and ground-cover to reduce water consumption. Avoid the use of chemical fertilizers and pesticides on lawns and landscaping elements. Native plant species often require little or none of these treatments. Avoid landscaping materials that leach pollutants into soils, groundwater, or nearby streams. For example, creosote or CCA-treated landscaping ties can be replaced with non-treated woods or with newer, less toxic pressure-treated timbers. Use reclaimed water (from retention ponds or cisterns, for example) for landscape irrigation.

ADVANTAGES: Conserves water and natural resources.

DISADVANTAGES: Alternative plantings may not be readily available.

5. REPLACE LAWN WITH LOW-IMPACT VEGETATION.

There are alternatives to a manicured lawn that are attractive and do not require fertilizer, special watering, and seldom or never need cutting. Buffalo grass is one such alternative to sod that may be suitable in many central and western US locations. Another alternative to the turf lawn is moss. Many varieties of moss will provide green, maintenance-free ground cover that looks good in all seasons and, once established, needs no tending, feeding, watering, or cutting and can actually benefit from light foot traffic.

ADVANTAGES: Conserves water and maintenance costs; eliminates run-off of chemicals into streams and wells.

DISADVANTAGES: May not be an esthetically acceptable alternative.

FURTHER READING

Energy-Efficient and Environmental Landscaping, A. S. Moffat, M. Schiler, and the staff of *Green Living*, Appropriate Solutions Press, 1994.

Landscaping Design that Saves Energy, A. S. Moffat and M. Schiler, New York: William Morrow and Company, Inc., 1991.

Landscaping for Energy Conservation, W. R. Nelson, available from the Building Research Council, College of Fine and Applied Arts, University of Illinois at Urbana-Champaign, One East Saint Mary's Road, Champaign, IL 61820, 1991.

"Landscaping for Energy Efficiency," The Energy Efficiency and Renewable Energy Clearinghouse (EREC), <http://www.eren.doe.gov/erec/factsheets/landscape.html>.

"Landscaping Gets Back to Nature," Brad Horn, *Environmental Design & Construction*, May/June 1998.

Landscaping with Native Trees, Guy Sternberg and Jim Wilson, New York: Houghton Mifflin Co., 1995.

"Trees, Saving Energy Naturally," Southern California Edison, 800-952-5062.

The Wild Lawn Handbook: Alternatives to the Traditional Front Lawn, Stevie Daniels, IDG Books Worldwide, 1997.

Xeriscape Gardening: Water Conservation for the American Landscape, C. Ellefson, New York: Macmillan Publishing Company, 1992.

"Xeriscape Plant Guide," Denver Water, 1996.

APPENDIX

PROFESSIONAL ASSOCIATIONS AND RESEARCH CENTERS

ADHESIVE AND SEALANT COUNCIL
1627 K Street, NW
Suite 1000
Washington, DC 20006-1707
202-452-1500
www.ascouncil.org

AMERICAN ASSOCIATION OF NURSERYMEN
(AAN)
1240 I Street, NW, Suite 500
Washington, DC 20005
202-789-2900

AMERICAN CONCRETE INSTITUTE (ACI)
INTERNATIONAL
Farmington Hills, MI 48333;
248-848-3700
www.aci-int.org

AMERICAN FIBERBOARD ASSOCIATION
AMERICAN HARDBOARD ASSOCIATION
1210 W. Northwest Highway
Palatine, IL 60067
847-934-8800

AMERICAN INSTITUTE OF TIMBER
CONSTRUCTION
7012 S. Revere Parkway, Suite 140
Englewood, CO 80112
303-792-9559
www.aitc-glulam.org

APA—THE ENGINEERED WOOD ASSOCIATION
P.O. Box 11700
Tacoma, WA 98411-0700
253-565-6600
www.apawood.org

AMERICAN NATIONAL STANDARDS INSTITUTE
11 West 42nd Street, 13th Floor
New York, NY 10036
212-642-4900
www.ansi.org

AMERICAN SOCIETY FOR TESTING AND
MATERIALS
100 Barr Harbor Drive
West Conshohocken, PA 19428
610-832-9500
www.astm.org

AMERICAN SOCIETY OF CIVIL ENGINEERS
1801 Alexander Bell Drive
Reston, VA 20191-4400
800-548-2723
www.asce.org

AMERICAN SOCIETY OF LANDSCAPE
ARCHITECTS
636 Eye Street, NW
Washington, DC 20001-3736
202-898-2444
202-898-1185 (fax)
www.asla.org

AMERICAN WATER WORKS ASSOCIATION
6666 W. Quincy Avenue
Denver, CO 80235
303-794-7711
www.awwa.org

AMERICAN WOOD PRESERVERS ASSOCIATION
P.O. Box 5690
Granbury Texas 76049-0690
817-326-6300
817-326-6306 (fax)
awpa@itexas.net

AMERICAN WOOD PRESERVERS INSTITUTE
2750 Prosperity Avenue, Suite 550
Fairfax, Virginia 22031-4312
800-356-AWPI
info@awpi.org
www.awpi.org

BRICK INDUSTRIES ASSOCIATION
11490 Commerce Park Drive
Reston, VA 20191-1525
703-620-0010
www.bia.org

BUILDING SEISMIC SAFETY COUNCIL
National Institute of Building Sciences
1090 Vermont Ave., NW, Suite 700
Washington, DC 20055
202-289-7800
www@nibs.org

BUILDING STONE INSTITUTE
PO Box 5047
White Plains, NY 10602-5047
914-232-5725

CALIFORNIA REDWOOD ASSOCIATION
405 Enfrente Drive, Suite 200
Novato, CA 94949
415-382-0662
www.calredwood.org

CANADA MORTGAGE AND HOUSING
CORPORATION
Housing Information Center
700 Montreal Road
Ottawa, ON, Canada K1A 0P7
613-748-2367
www.cmhc-schl.gc.ca

CANADIAN CONSTRUCTION MATERIALS
CENTRE
Institute for Research in Construction
National Research Council
Montreal Road, Bldg. M-24
Ottawa, ON, Canada K1A 0R6
613-993-6189
www.nrc.ca/ccmc

CONSTRUCTION SPECIFICATIONS INSTITUTE
99 Canal Center Plaza, Suite 300
Alexandria, VA 22314-1588
703-684-0300
www.csinet.org

COPPER DEVELOPMENT ASSOCIATION
260 Madison Avenue
New York, NY 10016
800-232-3282
www.copper.org

ENERGY EFFICIENCY AND RENEWABLE
ENERGY CLEARINGHOUSE (EREC)
P.O. Box 3048
Merrifield, VA 22116
800-DOE-EREC (363-3732)
703-893-0400

ENERGY EFFICIENT BUILDING ASSOCIATION
10740 Lyndale Avenue South
Suite 10W
Bloomington, MN 55420
952-881-1098
www.eeba.org

FOREST PRODUCTS LABORATORY
US Dept. of Agriculture
One Gifford Pinchot Drive
Madison, WI 53705-2398
608-231-9200
www.fpl.fs.fed.us/

FOREST PRODUCTS SOCIETY
2801 Marshall Court
Madison, WI 53705-2295
608-231-1361
608-231-2152 (fax)
www.forestprod.org

HARDWOOD PLYWOOD & VENEER
ASSOCIATION
PO Box 2789
Reston, VA 20195-0789
703-435-2900
www.hpva.org

INTERNATIONAL ASSOCIATION OF STONE
RESTORATION AND CONSERVATION
30 Eden Alley, Suite 301
Columbus, OH 43215
614-461-5852

INTERNATIONAL CODE COUNCIL
5203 Leesburg Pike, Suite 708
Falls Church, VA 22041
703-931-4533
703-379-1546 (fax)
www.intlcode.org

INTERNATIONAL CONCRETE REPAIR
INSTITUTE (ICRI)
1323 Shepard Drive, Suite D
Sterling, VA 21064
703-450-0116
703-450-0119 (fax)
www.icri.org

INTERNATIONAL CONFERENCE OF BUILDING
OFFICIALS
5360 S. Workman Mill Road
Whittier, CA 90601
800-336-1963
www.icbo.org

INTERNATIONAL REMODELING
CONTRACTORS ASSOCIATION
17 S. Main Street
E. Granby, CT 06026
800-937-4722
www.remodelingassociation.com

MASON CONTRACTORS ASSOCIATION OF
AMERICA
1910 S. Highland Avenue, Suite 101
Lombard, IL 60148
630-705-4200
www.masoncontractors.com

THE MASONRY SOCIETY
2619 Spruce Street, Suite B
Boulder, CO 80302-3808
303-939-9700

NAHB REMODELERS COUNCIL
1201 15th Street, NW
Washington, DC 20005
202-822-0212

NATIONAL ARBOR DAY FOUNDATION (NADF)
100 Arbor Avenue
Nebraska City, NE 68410

NATIONAL ARBORISTS ASSOCIATION
Route 101, P.O. Box. 1094
Amherst, NH 03031-1094
800-733-2622
603-673-3311
www.natlarb.com

NATIONAL ASSOCIATION OF THE
REMODELING INDUSTRY
3800 N. Fairfax Drive, Suite 2
Arlington, VA 22203-1627
703-276-7600
www.ebtech.com

NATIONAL ASSOCIATION OF OIL HEAT
SERVICE MANAGERS
PO Box 380
Elmwood Park, NJ 07407

NATIONAL CONCRETE MASONRY ASSOCIATION
2302 Horesepen Road
Herndon, VA 20171-3499
703-713-1900
www.ncma.org

NATIONAL FRAME BUILDERS ASSOCIATION
4840 W. 15th Street, Suite 1000
Lawrence, KS 66049-3876
800-844-3781
www.knight.idir.net

NATIONAL PAINT AND COATINGS
ASSOCIATION
1500 Rhode Island Avenue, NW
Washington, DC 20005
202-462-6272
www.paint.org

NATIONAL PARTICLEBOARD ASSOCIATION
18928 Premiere Court
Gaithersburg, MD 20879-1569
301-670-0604
www.pbmdf.com

NATIONAL TECHNICAL INFORMATION SERVICE
US Department of Commerce
5285 Port Royal Road
Springfield, VA 22161
800-553-6847
www.ntis.gov

NORTH AMERICAN SOCIETY FOR
TRENCHLESS TECHNOLOGY
1655N Ft. Myer Drive, Suite700
Arlington, VA 22209
703-351-5252
703-351-5261 (fax)
www.nastt.org

PORTLAND CEMENT ASSOCIATION
5420 Old Orchard Road
Skokie, IL 60077
800-868-6733
847-966-6200
847-966-9781 (fax)

SEALANT, WATERPROOFING, AND
RESTORATION INSTITUTE
2841 Main
Kansas City, MO 64108
816-472-7974
www.swrionline.org

SOUTHERN FOREST PRODUCTS ASSOCIATION
PO Box 641700
Kenner, LA 70064-1700
504-443-4464
www.sfpa.org

STUCCO MANUFACTURERS ASSOCIATION
507 Evergreen Road
Pacific Grove, CA 93950
408-649-3466

SUSTAINABLE BUILDINGS INDUSTRY COUNCIL
(SBIC)
1331 H Street, N.W., Suite 1000
Washington, DC 20005
202-628-7400
202-393-5043 (fax)
www.sbicouncil.org

TRENCHLESS INFORMATION CENTER
Northeast Consulting, Inc.
22 Jewelberry Drive
Webster, NY 14580
716-787-1519
716-787-0184 (fax)
www.no-dig.com

U.S. GREEN BUILDING COUNCIL
110 Sutter Street, Suite 410
San Francisco, CA 94104
415-445-9500
415-445-9111 (fax)
www.usgbc.org

WESTERN RED CEDAR LUMBER ASSOCIATION
1100-555 Bayard Street
Vancouver, BC, Canada V7X 1S7
604-684-0266
www.coti.org/WRCLA

WESTERN RED CEDAR LUMBER ASSOCIATION
Vancouver, British Columbia, Canada V7X1S7;
604-684-0266
www.wrcla.org

WESTERN WOOD PRODUCTS ASSOCIATION
522 SW 5th Avenue
Portland, OR 97204-2122
503-224-3930
www.wwpa.org

WOOD TRUSS COUNCIL OF AMERICA
6425 Normandie Lane
Madison, WI 53719
608-274-4849
www.trusspro.com/wtea/

THE REHAB GUIDE

VOLUME ONE: FOUNDATIONS

VOLUME TWO: EXTERIOR WALLS

VOLUME THREE: ROOFS

VOLUME FOUR: WINDOWS AND DOORS

VOLUME FIVE: PARTITIONS, CEILINGS, FLOORS AND STAIRS

VOLUME SIX: KITCHENS & BATHS

VOLUME SEVEN: ELECTRICAL/ELECTRONICS

VOLUME EIGHT: HVAC/PLUMBING

VOLUME NINE: SITE WORK

U.S. Department of Housing and Urban Development
Washington, DC 20410-6000

Official Business
Penalty for Private Use, \$300

August 2000
HUD-DU100C000005956

